

YAMAHA

MIDI KEYBOARD



Owner's Manual

PRECAUTIONS

PLEASE READ CAREFULLY BEFORE PROCEEDING

* Please keep these precautions in a safe place for future reference.



WARNING

Always follow the basic precautions listed below to avoid the possibility of serious injury or even death from electrical shock, short-circuiting, damages, fire or other hazards. These precautions include, but are not limited to, the following:

- Do not open the instrument or attempt to disassemble the internal parts or modify them in any way. The instrument contains no user-serviceable parts. If it should appear to be malfunctioning, discontinue use immediately and have it inspected by qualified Yamaha service personnel.
- Do not expose the instrument to rain, use it near water or in damp or wet conditions, or place containers on it containing liquids which might spill into any openings.
- If the AC adaptor cord or plug becomes frayed or damaged, or if there is a sudden loss of sound during use of the instrument, or if any unusual smells or smoke should appear to be caused by it, immediately turn off the power switch, disconnect the adaptor plug from the outlet, and have the instrument inspected by qualified Yamaha service personnel.
- Use the specified adaptor (PA-1D or an equivalent recommended by Yamaha) only. Using the wrong adaptor can result in damage to the instrument or overheating.
- Before cleaning the instrument, always remove the electric plug from the outlet. Never insert or remove an electric plug with wet hands.
- Check the electric plug periodically and remove any dirt or dust which may have accumulated on it.



CAUTION

Always follow the basic precautions listed below to avoid the possibility of physical injury to you or others, or damage to the instrument or other property. These precautions include, but are not limited to, the following:

- Do not place the AC adaptor cord near heat sources such as heaters or radiators, and do not excessively bend or otherwise damage the cord, place heavy objects on it, or place it in a position where anyone could walk on, trip over, or roll anything over it.
- When removing the electric plug from the instrument or an outlet, always hold the plug itself and not the cord.
- Do not connect the instrument to an electrical outlet using a multiple-connector. Doing so can result in lower sound quality, or possibly cause overheating in the outlet.
- Unplug the AC power adaptor when not using the instrument, or during electrical storms.
- Always make sure all batteries are inserted in conformity with the +/- polarity markings. Failure to do so might result in overheating, fire, or battery fluid leakage.
- Always replace all batteries at the same time. Do not use new batteries together with old ones. Also, do not mix battery types, such as alkaline batteries with manganese batteries, or batteries from different makers, or different types of batteries from the same maker, since this can cause overheating, fire, or battery fluid leakage.
- Do not dispose of batteries in fire.
- Do not attempt to recharge batteries that are not intended to be charged.
- If the instrument is not to be in use for a long time, remove the batteries from it, in order to prevent possible fluid leakage from the battery.
- Keep batteries away from children.
- Before connecting the instrument to other electronic components, turn off the power for all components. Before turning the power on or off for all components, set all volume levels to minimum.
- Do not expose the instrument to excessive dust or vibrations, or extreme cold or heat (such as in direct sunlight, near a heater, or in a car during the day) to prevent the possibility of panel disfiguration or damage to the internal components.
- Do not use the instrument near other electrical products such as televisions, radios, or speakers, since this might cause interference which can affect proper operation of the other products.
- Do not place the instrument in an unstable position where it might accidentally fall over.
- Before moving the instrument, remove all connected adaptor and other cables.
- When cleaning the instrument, use a soft, dry cloth. Do not use paint thinners, solvents, cleaning fluids, or chemical-impregnated wiping cloths. Also, do not place vinyl, plastic or rubber objects on the instrument, since this might discolor the panel or keyboard.
- Do not rest your weight on, or place heavy objects on the instrument, and do not use excessive force on the buttons, switches or connectors.
- Do not operate the instrument for a long period of time at a high or uncomfortable volume level, since this can cause permanent hearing loss. If you experience any hearing loss or ringing in the ears, consult a physician.

Yamaha cannot be held responsible for damage caused by improper use or modifications to the instrument, or data that is lost or destroyed.

Always turn the power off when the instrument is not in use.

Make sure to discard used batteries according to local regulations.

* The LED display and diagrams in this owner's manual are for instructional purposes only, and may be different from the ones on your instrument.

Welcome to the CBX-K2

Congratulations and thank you for purchasing the Yamaha CBX-K2 MIDI Keyboard!

The CBX-K2 is a sophisticated, yet compact **MIDI keyboard controller**, for use with computers and MIDI music systems. It allows you to **play connected tone generators** and rhythm machines, and **enter performance data** to sequencers and computers. It features a sophisticated **touch-sensitive keyboard** that can be adjusted to cover the **full 128-note MIDI range**. It also provides a **wealth of MIDI controls** that allow you to **send virtually any MIDI message** directly from the keyboard. Moreover, the CBX-K2 has three built-in assignable controllers: **Assignable Wheel**, **Assignable Slider** and **Assignable Footswitch**. The Assignable Wheel and Assignable Slider can be set to control virtually any parameter on your connected tone generator or sequencer in real time, while the Assignable Footswitch can be used for sustain, certain sequencer controls, or as an alternate SHIFT button. Because of its **portable size**, convenient **battery/AC adaptor power supply**, **compatibility with General MIDI (GM) and XG**, and extraordinarily **powerful and comprehensive MIDI control functions**, the CBX-K2 is an invaluable tool — a MIDI Swiss army knife, of sorts — for all MIDI musicians and performers.

IMPORTANT ■ *The CBX-K2 does not contain an internal tone generator. In order to play sounds from the CBX-K2, you need an external tone generator, such as the Yamaha MU series or TG series tone generators.*

NOTE ■ *The many MIDI functions and features of the CBX-K2 may not be supported by your particular MIDI device. Be sure to refer to the owner's manual of your particular MIDI device when using it with the CBX-K2.*

Contents

The CBX-K2 — What It Is and What It Can Do	6
What It Is	6
What It Can Do	6
How to Use This Manual	7
Panel Controls and Terminals	8
■ Note Range of the CBX-K2 (with Octave Shift)	9
■ Default Settings of the CBX-K2	10
Guided Tour	
Power Supply	12
■ Using a Power Adaptor	12
■ Using Batteries	12
■ When to Replace the Batteries	12
Setting Up Your CBX-K2	13
What You'll Need	13
Setup Examples	13
■ With Computer and Tone Generator	13
■ With Sequencer	14
■ With Tone Generator	14
■ With Main Keyboard and Tone Generator	15
Making the Connections	15
Playing and Using Your CBX-K2	16
Selecting and Playing Voices	16
Changing the Voice Banks	17
Changing the Octave Range	17
Using the Pitch Bend Wheel, Assignable Wheel, and Assignable Slider	18
Re-assigning the Assignable Wheel and Slider	18
Changing the Touch Sensitivity of the Keyboard	19
Reference	
Using the SHIFT-Related Functions	20
Basic Operations	21
■ Selecting Group A and Group B Functions	21
■ Entering Values	21
■ Value Entry — Some Specific Examples and Anomalies	21
Setting the Functions	22
Group A Operations	22
Group B Operations	24
Group A Functions — List	26
Group B Functions — List	28
Assignable Wheel & Slider — Controller Number List	30
About MIDI	31
MIDI Messages Transmitted by the CBX-K2	31
CHANNEL MESSAGES	31
SYSTEM MESSAGES	33
MIDI Data Format	34
MIDI Reception	34
MIDI Transmission	34
MIDI Implementation Chart	36
Troubleshooting	37
Error Messages	38
Specifications	39
About RPN and NRPN	39
Index	40

The CBX-K2 — What It Is and What It Can Do

What It Is

The CBX-K2 is a compact, highly portable 49-key MIDI keyboard, designed especially for use with computers and MIDI music systems. The CBX-K2 does not generate any sound itself, but can be used as a keyboard controller for playing sounds on a connected tone generator or rhythm machine. It's also ideal for recording to sequencers and computers. The keyboard is touch-sensitive and its octave range can be changed to cover the full 128-note MIDI range.

The true power and flexibility of the CBX-K2 is in its comprehensive MIDI controls. The CBX-K2 allows you to send virtually any type of MIDI message to connected MIDI devices. Pre-programmed commands provide easy control of basic sequencer/rhythm machine functions such as Start, Stop, Tempo and Song Select, while comprehensive program change commands let you easily select program banks and voices.

Most importantly, though, the CBX-K2 has an Assignable Wheel and Slider that can be set for control of any controller number. This means that you can use the Assignable Wheel to control a wide variety of parameters on your connected tone generator — such as Volume, Pan, Brightness, and the Depth of various effects — in real time. This gives you expressive control over different aspects of the sound in live performance.

The CBX-K2 is also the latest instrument in the Yamaha line to support the XG format, a new addition to the General MIDI standard. In short, XG provides for more instrument sounds and variations, and greater expressive control over voices and effects. With the use of the Assignable Wheel or Slider on the CBX-K2, you have direct real-time control over many of these newly supported functions and parameters.

What It Can Do

Here are a few application ideas on how you can use the CBX-K2. The list below is not comprehensive, but is meant to be a general guide to the possibilities and provide a starting point or springboard for your own creative ideas and explorations.

● **Using With a MIDI Tone Generator**

In one of the most basic setups, you can play a connected tone generator from the CBX-K2. Because it's so compact and portable, you can even use it as a hand-held keyboard for live performance.

● **Using as a Second Keyboard or Dedicated MIDI Controller**

The CBX-K2 is small enough to fit on top of nearly any keyboard, making it perfect as a second keyboard. Since the CBX-K2 has a MIDI IN terminal, you can connect it between your main keyboard and your tone generator, and use the extensive MIDI capabilities of the CBX-K2 for greater expressive control during your performance.

● **Using in a MIDI Music System**

Combined with a laptop computer and a compact tone generator (like the General MIDI/XG-compatible Yamaha MU100R), the CBX-K2 gives you comprehensive music making power — for recording, composing, arranging, practicing, and editing — in a portable system that's ready to go wherever you go. The CBX-K2 is an ideal addition to larger MIDI studios as well, since it provides far greater MIDI control and flexibility than nearly any other keyboard controller. Use it along side your main MIDI keyboard as a kind of MIDI Swiss army knife — sending necessary MIDI messages, working the real-time controllers, or editing already recorded sequencer tracks.

● **Multimedia**

Since it's portable and compatible with the General MIDI and XG formats, the CBX-K2 is a natural for multimedia applications. Because of its ease of use and comprehensive functions, it's the only keyboard you'll ever need for recording and editing MIDI data on your multimedia creations.

How to Use This Manual

By and large, the CBX-K2 is very easy to use and this manual is self-explanatory. However, we strongly recommend that you take time to read the manual — especially before trying some of the more sophisticated MIDI functions. Read through **all** of the initial sections first, then go on to the “**Guided Tour**” to set up your CBX-K2, learn how to use its various functions, and try out some of the practical application examples to help you become more familiar with its operations. For those who need to delve deeper, the “**Reference**” section provides at-a-glance information and important details on all functions.

The following conventions are used throughout this manual:

- * Panel buttons and controls are indicated as they appear on the actual instrument. (For example, **SHIFT** and **OCTAVE SHIFT ▶**).
- * The functions and features assigned to the keyboard are shown like this: **BANK SELECT** and **MIDI CH**.
- * Unless indicated otherwise, **ENTER** refers to either of the **ENTER** keys, **HEXADECIMAL** or **DECIMAL**. However, when you wish to enter a decimal value, make sure to press **DECIMAL**. Likewise, when entering a hexadecimal number, make sure to press **HEXADECIMAL**.
- * Actual MIDI data messages (in hexadecimal) are indicated as follows: <<FE>> and <<En 00 40>>, etc.
- * Operation steps are indicated as follows:

Example	Actual Operation
SHIFT + START	While holding down the SHIFT button, press START (D1).
SHIFT + GM ON → ENTER	While holding down the SHIFT button, first press GM ON (F#1), then press ENTER (either HEXADECIMAL or DECIMAL).

Panel Controls and Terminals

■ Front Panel

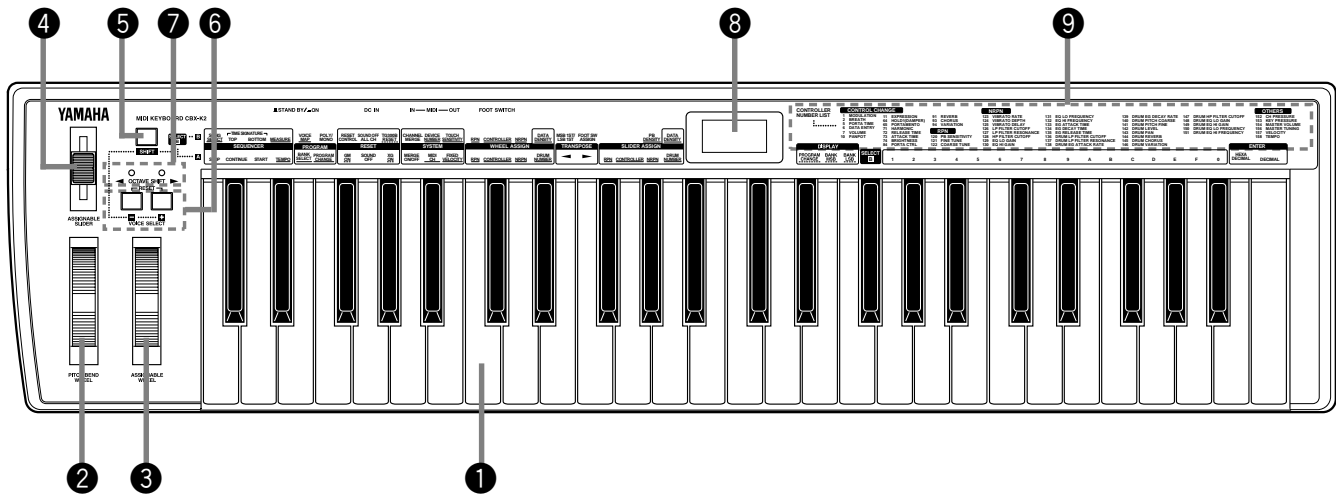

① Keyboard

The CBX-K2 has a 49-key, 4-octave keyboard (C1 to C5), featuring initial touch (velocity) control. All note on, note off and velocity data is transmitted via the MIDI OUT terminal. When used with the **SHIFT** button, the keys are used for changing various settings and sending special MIDI messages. (Page 20.)

About the Functions of the CBX-K2: The functions are divided into two groups: Group A and Group B. The Group A and B functions are shown on the panel, above the left section of the keyboard. Several functions can be used by pressing only the relevant key; in other words, pressing **ENTER** is not necessary. These functions, such as Sequencer Stop and Start, are shown on the panel without underline.

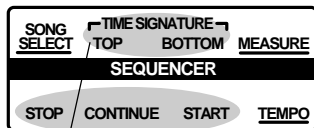

These non-underlined functions can be used without pressing **ENTER**.

The right section of the keyboard serves as value entry and is used for those functions whose names are underlined on the panel and require value entry, such as Program Change and Tempo.

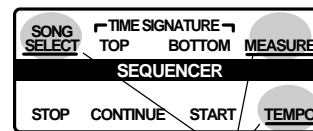

These underlined functions require value entry and pressing **ENTER**.

Functions whose names appear with a dashed underline on the panel (for example, GM ON and XG ON) require pressing **ENTER**.

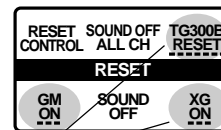

These functions with dashed underline need no value entry, but require pressing **ENTER**.

Value entry on the CBX-K2 can be done in two number systems: Decimal and Hexadecimal. The keys labeled A through F are for Hexadecimal entry.

NOTE ■ The normal (default) velocity range of the CBX-K2 is from 1 to 127. The range differs according to the Touch Sensitivity setting (pages 19, 28).

2 Pitch Bend Wheel (Pitch Bend)

This spring-loaded Wheel controls Pitch Bend. (Page 18.)

3 Assignable Wheel

When the CBX-K2 is turned on, this Wheel (with center detent) is set to control Modulation Depth of the connected MIDI device. It can be set to control other functions; see on pages 18 and 26 for details. Turning the Wheel will momentarily show the currently assigned controller number in the LED display.

4 Assignable Slider

When the CBX-K2 is turned on, this Slider is set to control the data entry of the connected MIDI device. It can be set to control other functions; see on pages 18 and 26 for details. Moving the Slider will momentarily show the currently assigned controller number in the LED display.

5 SHIFT Button

This button is used to access the “hidden” functions of the CBX-K2. Used with the ◀OCTAVE SHIFT / ▶OCTAVE SHIFT buttons (when the LED display is set to Program Change, Bank MSB, or Bank LSB), it allows you to step up or down through program numbers. (Page 16.)

Whenever turned on, the program number is set to 001. Used with the keys of the keyboard, it allows you to access the sophisticated MIDI control functions. (Page 20.)

6 ◀OCTAVE SHIFT / ▶OCTAVE SHIFT Buttons

These buttons are used to change the octave range of the keyboard, allowing you to play across the entire range of MIDI notes (C-2 to G8). When the octave setting is modified, the current octave setting is momentarily displayed on the LED. (Page 17.) Press both of these buttons together to restore the normal octave setting (C1 to C5).

7 ◀OCTAVE SHIFT / ▶OCTAVE SHIFT Lamps

These lamps provide several indications:

- During normal playing conditions, these (along with the LED display) indicate the octave setting of the keyboard, up (▶OCTAVE SHIFT) or down (◀OCTAVE SHIFT). Both light together for the normal octave setting. When changing the octave setting, these flash to indicate the number of octaves, up or down. (Page 17.)
- When using some of the “hidden” functions, these flash when a MIDI message is transmitted or when a function is executed.

Note Range of the CBX-K2 (with Octave Shift)

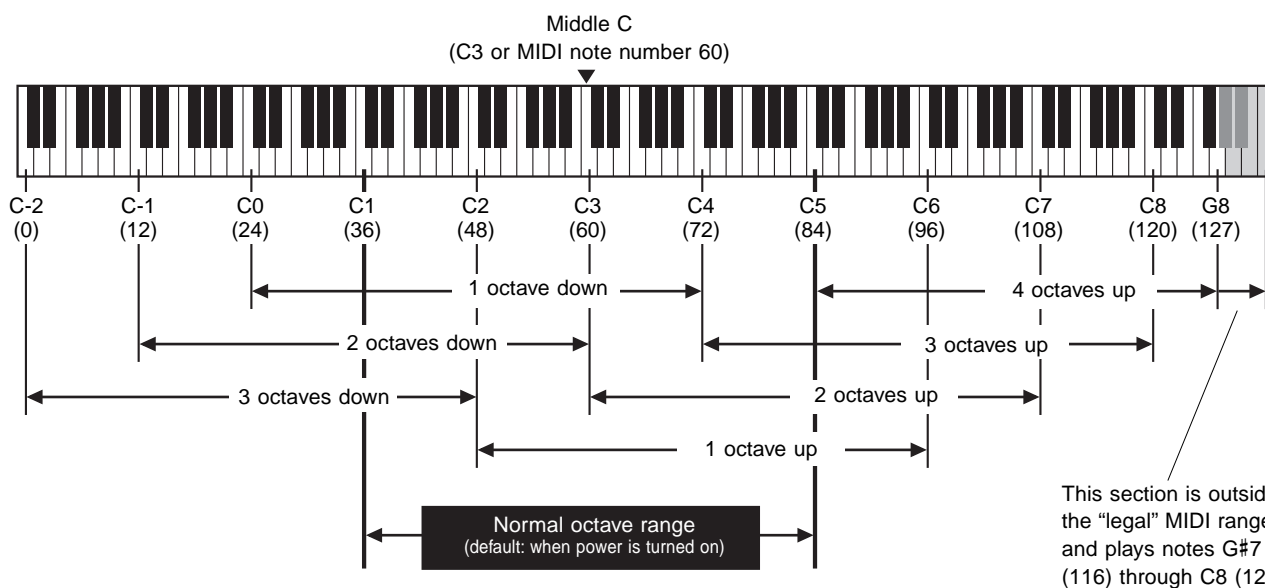

Panel Controls and Terminals

- The right lamp flashes quickly when a MIDI error happens. The lamp flashes until you press any one of the panel buttons.

⑧ LED Display

In normal playing conditions, this displays the currently selected program number (when **PROGRAM CHANGE** is selected in **DISPLAY**; see on page 22).

When moving the Assignable Wheel or Slider, this flashes the currently active Controller number. (When assigned to RPN or NRPN, the display does not flash.) For the Wheel, the default is **001** - Modulation; for the Slider, the default is **006** - Data Entry.

When changing the octave setting, this momentarily indicates the number of octaves, up or down, from the normal octave setting. The range is -3 (3 octaves down) to 0 (normal) to 4 (4 octaves up).

The display also indicates the status of the MIDI control operations. Depending on the operation performed, the display may:

- Flash rapidly, indicating the selected MIDI message has been sent. (Ex.: When pressing **SHIFT** + **STOP**.)
- Show the current condition or value. (Ex.: When pressing **SHIFT** + **TEMPO**.) It also displays the entered value when changing a function's setting.

⑨ CONTROLLER NUMBER LIST

This is a list of some of the main controller numbers (and their names) that can be used with the Assignable Wheel and Slider. (For a complete list, see on page 30.)

Default Settings of the CBX-K2

The CBX-K2 has no internal memory backup. As a result, all settings are returned to the factory default when turning the power off. The basic factory default settings are listed below.

- **Merge:** on
- **MIDI transmit channel:** 1
- **Octave range:** C1 – C5
- **Transpose:** normal (no transposition)
- **Fixed velocity:** off (keyboard is velocity sensitive)
- **Assignable Wheel:** Modulation
- **Assignable Slider:** Data entry MSB

■ User-configurable Defaults:

You can change certain power-on default settings of the CBX-K2. These include:

- * Reversing the MSB, LSB order. Hold down **◀ OCTAVE SHIFT** and turn the power on. (Pages 28, 29.)

■ Rear Panel

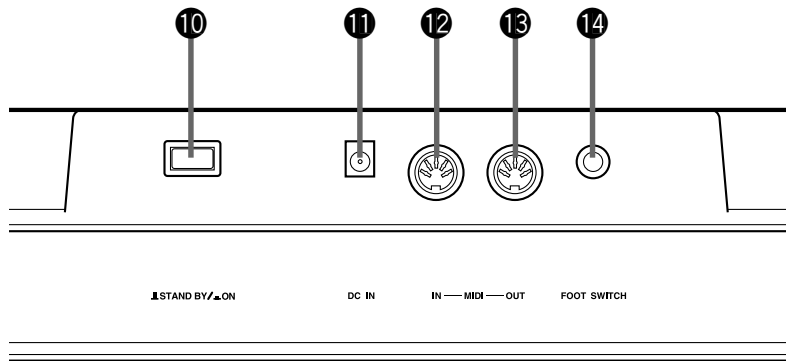

10 POWER Switch

Push this switch in to turn on the power. Each time the power is turned on, the CBX-K2 returns to the default condition. (See boxed section on page 10.)

11 DC IN Terminal

This is for connection to a PA-1D AC adaptor or another adaptor recommended by Yamaha.

12 MIDI IN Terminal

This is for connection to the MIDI OUT terminal of another MIDI device (such as a MIDI keyboard, sequencer or computer that has a MIDI interface), for input of that device's data. By using the MIDI Merge function, received data can be combined with the data generated by the CBX-K2 and transmitted via the MIDI OUT terminal.

13 MIDI OUT Terminal

This is for connection to the MIDI IN terminal of another MIDI device (such as a MIDI tone generator, sequencer or computer that has a MIDI interface), for sending MIDI messages to that device.

14 FOOT SWITCH Jack (1/4" phone)

This is for connection of a pedal switch (such as the optional Yamaha FC4 or FC5). The default control for the Footswitch is sustain on/off (Controller #64). It can be set to control other functions; see on page 28 for details.

NOTE ■ Make sure that the Footswitch plug is properly connected to the FOOT SWITCH terminal before turning on the power.

■ Do not press the Footswitch while turning the power on. Doing this changes the recognized polarity of the Footswitch, resulting in reversed Footswitch operation.

Setting Up the CBX-K2 in Your Music System

Whatever your system, you should follow the basic instructions below when setting up your CBX-K2. Use the example illustrations as a general guide when making the connections with your own system.

Power Supply

Your CBX-K2 will run from the included power adaptor, PA-1D or an equivalent. Batteries can also be used (see below). However, we strongly recommend that you use the power adaptor.

NOTE ■ Before making any connections, make sure that all equipment to be connected is turned off.

Using a Power Adaptor

Connect one end of the power adaptor (PA-1D) to the DC IN jack on the rear panel, and the other end to a suitable electrical outlet.

CAUTION! ⚠ ■ Do not attempt to use a power adaptor other than the PA-1D (or another adaptor recommended by Yamaha). The use of an incompatible adaptor may result in irreparable damage to the CBX-K2, and even pose a serious shock hazard.

■ Be sure to disconnect the power adaptor from the outlet when the CBX-K2 is not in use.

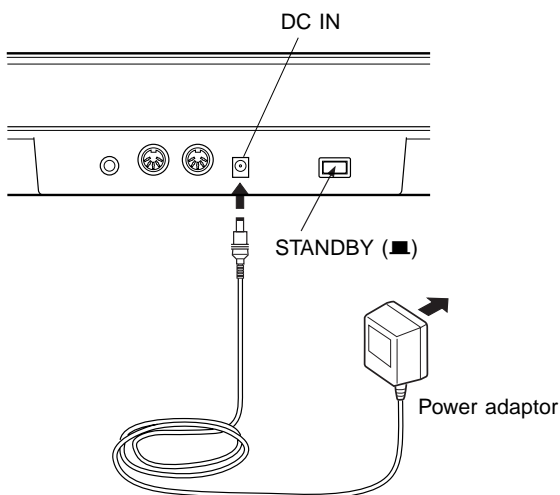

Using Batteries

To use the CBX-K2 on battery power, remove the battery compartment cover (as shown below) and insert six 1.5V AA size (SUM-3, R-6 or equivalent) batteries in the battery compartment. Make sure to follow the polarity indications on the bottom case.

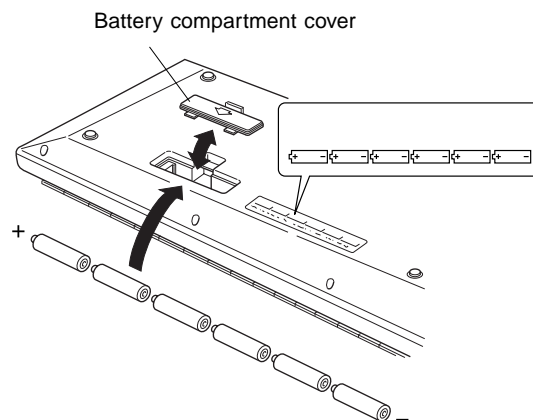

Securely replace the battery compartment cover when done installing the batteries.

When to Replace the Batteries

When the battery power runs too low to properly operate the CBX-K2, an “E !” message appears in the LED display. When this happens, replace all batteries with a complete set of six new batteries of the same type.

CAUTION! ⚠ ■ NEVER mix old and new batteries or different types of batteries! Also, to prevent possible damage due to battery leakage, remove the batteries from the instrument if it is not to be used for a long time.

Setting Up Your CBX-K2



All the devices must be turned off before making connections.

In this introductory section, you'll learn how to set up the CBX-K2 for use in your music system. A variety of setups are covered here; read through the one that most closely matches your own setup.

What You'll Need

Since the CBX-K2 is strictly a MIDI controller and does not generate any sound by itself, you'll need other data-receiving and sound-producing equipment. Basically, you will need:

- * The CBX-K2 and PA-1D AC power adaptor (or a set of batteries).
- * A MIDI device (such as a tone generator, keyboard or computer) which can receive and play back MIDI data, and at least one MIDI cable.
- * (Optional) An amplifier/speaker system, preferably stereo, with proper audio connecting cables. Alternately, you can use a set of stereo headphones.

Setup Examples

NOTE ■ All devices must be turned off before making connections.

■ The setup examples below show only the MIDI connections. The audio connections would vary according to the particular equipment you use. Refer to the owner's manuals of your other equipment for audio connection instructions.

When connecting the instrument to other MIDI devices, be sure to use only high-quality MIDI cables. Also, avoid using cables longer than 15 meters, since long cables can result in data errors.

With Computer and Tone Generator

In the small MIDI system below, the CBX-K2 is connected to a computer and a single tone generator. With the proper sequencing software on the computer, the CBX-K2 can be used both for recording performance data to the computer and playing the sounds of the connected tone generator. You can also conveniently use the CBX-K2 to start and stop the sequencer.

For tone generators with a built-in MIDI interface (such as the Yamaha MU100R)

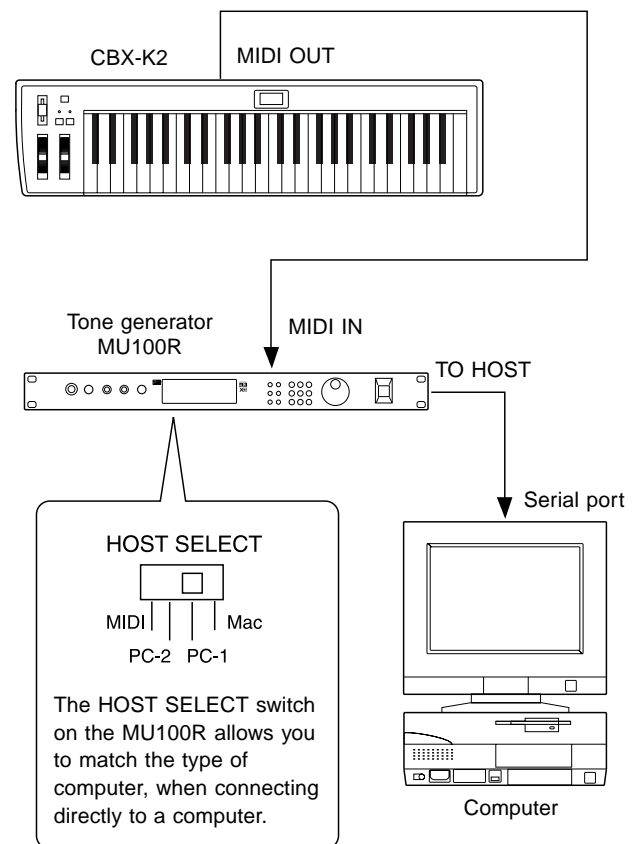

Connect the MIDI OUT terminal on the CBX-K2 to the MIDI IN terminal on the MU100R. The MU100R should be connected to the proper port on the computer. (For complete connection instructions, refer to the owner's manual of your particular tone generator.)

Setting Up Your CBX-K2

For tone generators without a built-in MIDI interface

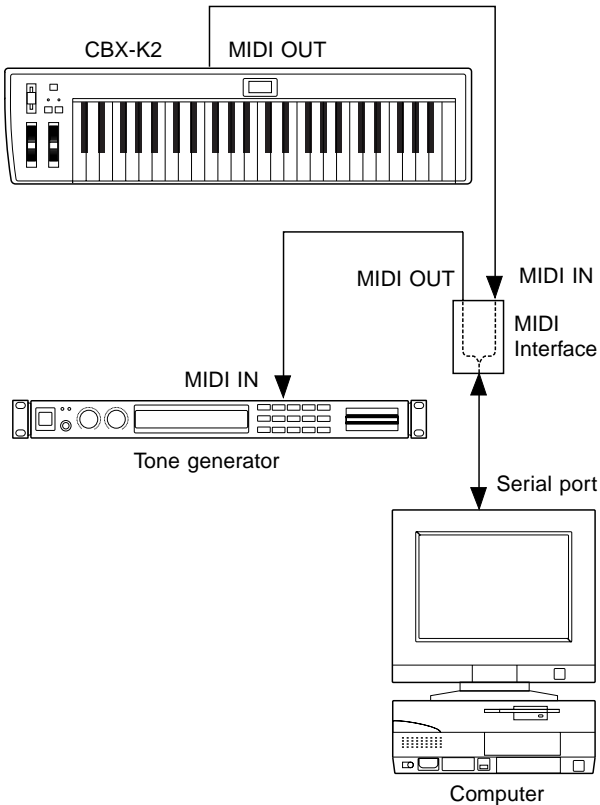

Connect the MIDI OUT terminal on the CBX-K2 to the MIDI IN terminal on the computer's MIDI interface. The tone generator should be connected to a MIDI OUT on the interface.

NOTE ■ Set the MIDI Thru (or Echo Back) setting on the sequencer software to ON.

As for the required MIDI settings for the computer and sequencer software, refer to the respective manuals.

With Sequencer

The CBX-K2 can be used with a stand-alone sequencer, for recording and editing performance data.

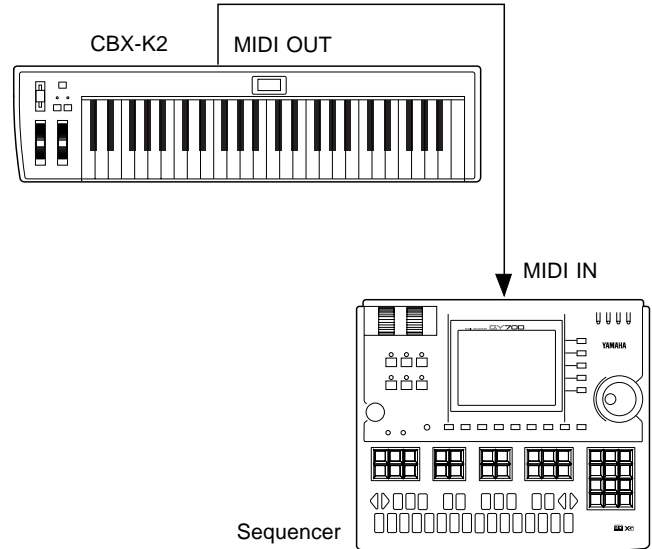

Connect the MIDI OUT terminal on the CBX-K2 to the MIDI IN terminal on the sequencer.

With Tone Generator

In the simple system below, the CBX-K2 is used to play the voices of the MU100R Tone Generator. This setup could also serve as a simple, yet powerful live performance rig, with the CBX-K2 being used as a portable keyboard controller.

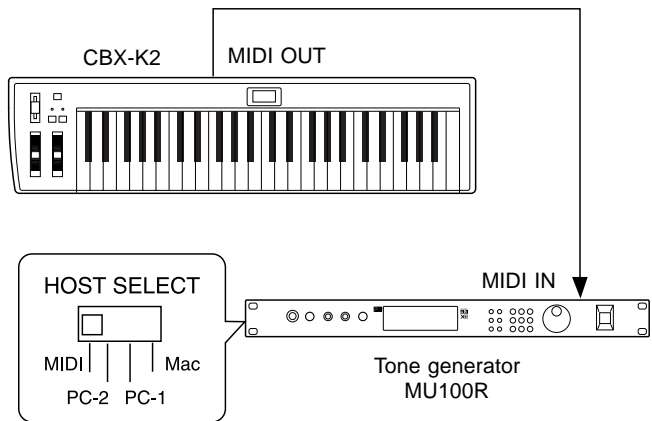

Connect the MIDI OUT terminal on the CBX-K2 to the MIDI IN terminal on the MU100R.

With Main Keyboard and Tone Generator

In this system, the CBX-K2 effectively serves as a second keyboard. The main keyboard (in this case, the Clavinova) is used to play both its own internal sounds and the sounds of the connected multi-timbral tone generator on one channel, while the CBX-K2 is used to play the sounds of the tone generator on another channel. This lets you play two sounds at once from the Clavinova, and play a third sound from the CBX-K2.

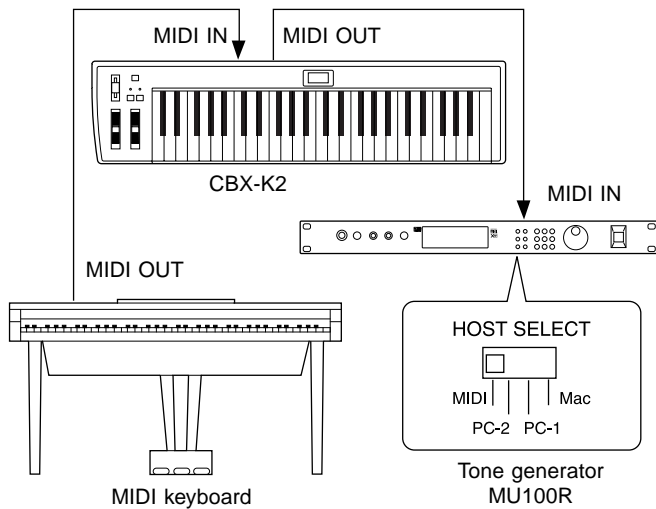

Connect the MIDI OUT terminal on the main keyboard to the MIDI IN terminal on the CBX-K2. Also connect the MIDI OUT terminal on the CBX-K2 to the MIDI IN terminal on the tone generator.

In a variation of the above setup, set the Clavinova and CBX-K2 to transmit on the same channel, and set the CBX-K2's MIDI Merge function to ON. This lets you play the tone generator from either keyboard and use the versatile MIDI functions of the CBX-K2 to control the tone generator — for example, changing the brightness of the sound in real time with the Assignable Wheel.

NOTE ■ When an external MIDI device is connected to the MIDI IN of the CBX-K2, the LED display may indicate a MIDI error. This is probably due to a longer-than-normal interval between active sensing messages received from the device, or could be the result of an improper connection. In such a case, the CBX-K2 automatically resets to Merge Off (pages 26, 34). Check the connected device or cable before continuing.

Making the Connections

CAUTION! ⚠ ■ Before making any connections, make sure that all equipment to be connected is set to minimum volume and turned off.

Operation

1. Connect the MIDI OUT terminal of the CBX-K2 to the MIDI IN terminal of the tone generator, sequencer or computer MIDI interface (as shown in the illustrations above).
2. Make all necessary audio connections, making sure first that all level controls on those devices are set to the minimum. (Refer to the owner's manuals of the devices you are using for more information on connections.)
3. Turn the power on for the various equipment in the following order:
 - 1) CBX-K2
 - 2) Computer
 - 3) Tone generator(s)
 - 4) Audio devices (mixer, amplifier, etc.)

When turning off the power, simply reverse the above order, turning off the CBX-K2 last.

Playing and Using Your CBX-K2

This section of the manual guides you through some of the basic features and functions of the CBX-K2. It also provides some advanced operation examples, so that you can get a feel for what the CBX-K2 is capable of, and how you can best use it. Master the basics in this section, and you'll have the experience and know-how to easily and confidently use any of the more advanced functions covered later in the **Reference** section.

In this section, you'll learn how to:

- Transmit program change messages and play the keyboard.
- Select a voice bank.
- Change the octave setting of the keyboard.
- Use the Pitch Bend and Assignable Wheels.
- Re-assign the controller for the Assignable Wheel and Slider.
- Change the Touch Sensitivity of the keyboard.

Selecting and Playing Voices

The CBX-K2 lets you select voices (or program numbers) on your connected MIDI device in two ways: stepping up or down through the program numbers, or directly selecting a specific program number.

- **To step up or down through the program numbers:** First, make sure that the program number is shown in the display (see the Display Program Change function, page 26). Then, simultaneously hold down **SHIFT** and press **OCTAVE SHIFT ▶** (to advance one program number), or press **◀ OCTAVE SHIFT** (to go back one program number).

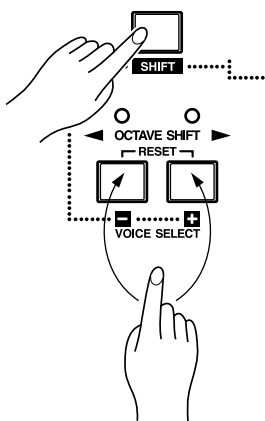

The program number in the LED display changes accordingly, and the **OCTAVE SHIFT** lamps quickly flash on and off. Release **SHIFT**, and play the keyboard to hear the newly selected voice.

To quickly move up or down through the program numbers, continuously hold down **SHIFT** and the appropriate **OCTAVE SHIFT** button.

When the CBX-K2 is turned on, the starting point for program change is 001. This means that when you first hold down **SHIFT** and press **OCTAVE SHIFT ▶**, program number 002 will be selected.

IMPORTANT! ■ Always release **SHIFT** before playing the CBX-K2 keyboard. Holding down **SHIFT** accesses the secondary A or B group or other functions, and you may inadvertently execute one of these functions by playing the keyboard while continuing to hold down **SHIFT**.

NOTE ■ This function does not “wrap around.” In other words, you cannot go back to program number 128 when at 001, or advance to program number 001 when at 128.

- **To change the program number:** While holding down **SHIFT**, press the key corresponding to **PROGRAM CHANGE** (F1), then the keys corresponding to the desired number, then the key corresponding to **DECIMAL**.

For example, to select program number 017, continue holding down **SHIFT** and press **PROGRAM CHANGE**, **1**, **7**, then **DECIMAL**. Release **SHIFT**, and play the keyboard to hear the newly selected Voice.

Changing the Voice Banks

Many currently available tone generators feature multiple banks of voices. The CBX-K2 can be used to quickly and easily select these additional banks. Some banks may not be available on your particular tone generator; check the manual for details.

Operation

1. Simultaneously hold down **SHIFT** and press **BANK SELECT**.

The LED display indicates the current Bank setting by alternately flashing the MSB and LSB values. (In this case, the default setting, both of these values are 000.)

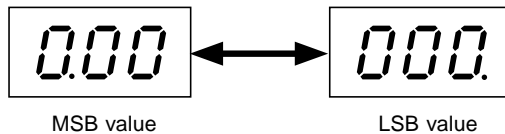

The display alternately flashes the MSB and LSB values.

2. While continuing to hold down **SHIFT**, enter the number 64 (press **6**, then **4**), then press **DECIMAL**.

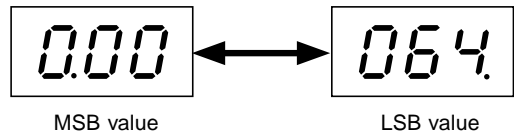

This sets the Bank to 064 (LSB value). The LED display alternately flashes the MSB and LSB values, 000 and 064.

To restore the original Bank (or select other Banks), hold down **SHIFT**, press **BANK SELECT**, **0** (or another number for a different Bank), and **DECIMAL**.

Changing the Octave Range

The range of the 4-octave keyboard can be easily shifted up or down to cover the full 10-1/2-octave (128-note) range of MIDI notes. (See on page 9 for the note range.)

Operation

- To shift the keyboard up one octave, press **OCTAVE SHIFT ▶**. To shift the keyboard down one octave, press **◀ OCTAVE SHIFT**.

When the octave range is changed, the LED display briefly indicates the new setting. The **OCTAVE SHIFT** lamps also rapidly flash one or more times, according to the selected octave range. For example, when the setting is changed to two octaves below normal, the left lamp flashes twice.

You can instantly restore the normal octave range by pressing both **◀ OCTAVE SHIFT**/**OCTAVE SHIFT ▶** buttons simultaneously.

NOTE ■ At the highest octave setting, keys outside the legal MIDI note range will repeat a previous octave.

Playing and Using Your CBX-K2

Using the Pitch Bend Wheel, Assignable Wheel, and Assignable Slider

These two wheels and slider let you control different aspects of the sound in realtime as you play. These controls affect the connected MIDI instrument.

Move the Pitch Bend Wheel as you play to change the pitch of the sound. Moving the wheel away from you bends the

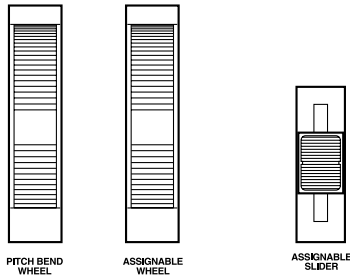

pitch up. The Pitch Bend Wheel is spring-loaded for returning to center (normal pitch).

Move the Assignable Wheel as you play to change the modulation of the sound (MIDI Controller #1). Moving the wheel away from you increases the modulation. Moving the Assignable Slider changes the Data Entry value (MIDI Controller #6). (Notice that the “006” flashes in the display, indicating data for Controller #6 is being transmitted.) The Assignable Wheel and Assignable Slider can also be set to control other functions; see the section below for details.

Depending on the connected device and the selected voice, there may be no response or change in the sound. Refer to the owner’s manual of the particular device for details.

Re-assigning the Assignable Wheel and Slider

As mentioned above, the Assignable Wheel and Slider can be used to control a variety of different functions. The default setting for the Wheel is modulation (MIDI Controller #1), and the default for the Slider is data entry (MIDI Controller #6). However, either can be set to control volume, pan position, attack or release time, coarse tuning or fine tuning, and reverb or chorus depth, among other Controllers. (For a complete list of the available Controllers and their numbers, see on page 30.)

Assignable Wheel / Operation

1. Simultaneously hold down **SHIFT** and press **CONTROLLER** in the **WHEEL ASSIGN** section.

The LED display indicates the current Assignable Wheel’s Controller number.

2. While continuing to hold down **SHIFT**, enter the number 10 (press **1**, then **0**), then press **DECIMAL**.

This sets the Assignable Wheel to Controller number 10 (Pan). Play the keyboard and move the Assignable Wheel as you play, and hear how the sound moves left and right in the stereo image as you move the Wheel. As you move the Wheel, the currently assigned Controller number appears in the LED display. The Assignable Wheel is particularly

suited to control numbers such as #10 (Pan) and #73 (Attack Time) because of its center detent.

Try entering other Controller numbers, repeating steps 1 and 2 above. (A short list of Controllers is printed on the panel. Try entering some of these; many—but not all—of these will have an obvious effect on the sound as you move the wheel.)

Assignable Slider / Operation

1. Simultaneously hold down **SHIFT** and press **CONTROLLER** in the **SLIDER ASSIGN** section.

The LED display indicates the current Assignable Slider’s Controller number.

2. While continuing to hold down **SHIFT**, enter the desired Controller number (for example, “7” for MIDI volume control), then press **DECIMAL**.

Play the keyboard and move the Assignable Slider as you play, and hear how the volume of the sound changes (if you are using Controller #7).

* You can also assign RPN and NRPN numbers to the Assignable Wheel or Slider. (Pages 26 and 30.)

Changing the Touch Sensitivity of the Keyboard

The Touch Sensitivity function lets you change how the Voices respond to your playing strength.

NOTE ■ *Touch Sensitivity is a “Group B” function. The “Group A” functions (such as Program Change, Bank Select, and Controller, which were covered above) are shown on the panel and explained in detail on pages 26 – 27. The Group B functions (listed and explained on pages 28 – 29) are also shown on the panel but are accessed differently than Group A functions.*

Operation

1. Simultaneously hold down **SHIFT**, press **SELECT B**, then **TOUCH SENSITIVITY**.

Pressing **SELECT B** first (before any function key) calls up the Group B functions. The LED display indicates the current Touch Sensitivity value.

2. While continuing to hold down **SHIFT**, enter the number **1**, then press **DECIMAL**.

This sets Touch Sensitivity to **1** (easy). Now, when you play the keyboard, even playing softly results in a reasonably loud sound.

Try entering other values (the range is 1–10), and hear how they affect the response of the keyboard. The default value is **10**, and can also be restored by simply turning the CBX-K2 off and on again.

NOTE ■ *When Fixed Velocity is set to a value other than 0 (off), the Touch Sensitivity setting has no effect.*

For more information on Touch Sensitivity, see footnote #5 on page 28.

This concludes the basic tour of some of the important functions of the CBX-K2. To find out more about how to use your CBX-K2, look through the **Reference** section that follows and try out some of the functions and operations that interest you.

Using the SHIFT-Related Functions

The enormous flexibility and power of the CBX-K2 is in its “hidden” or SHIFT-related functions — allowing you to send virtually any kind of MIDI message directly from the keyboard or use the Assignable Wheel/Slider for real-time control change.

Many of the functions can be done with one or two key-strokes, while others require you to enter a number value and press one of the **ENTER** keys to execute the function. All functions can be accessed or executed by using one of the operations described below.

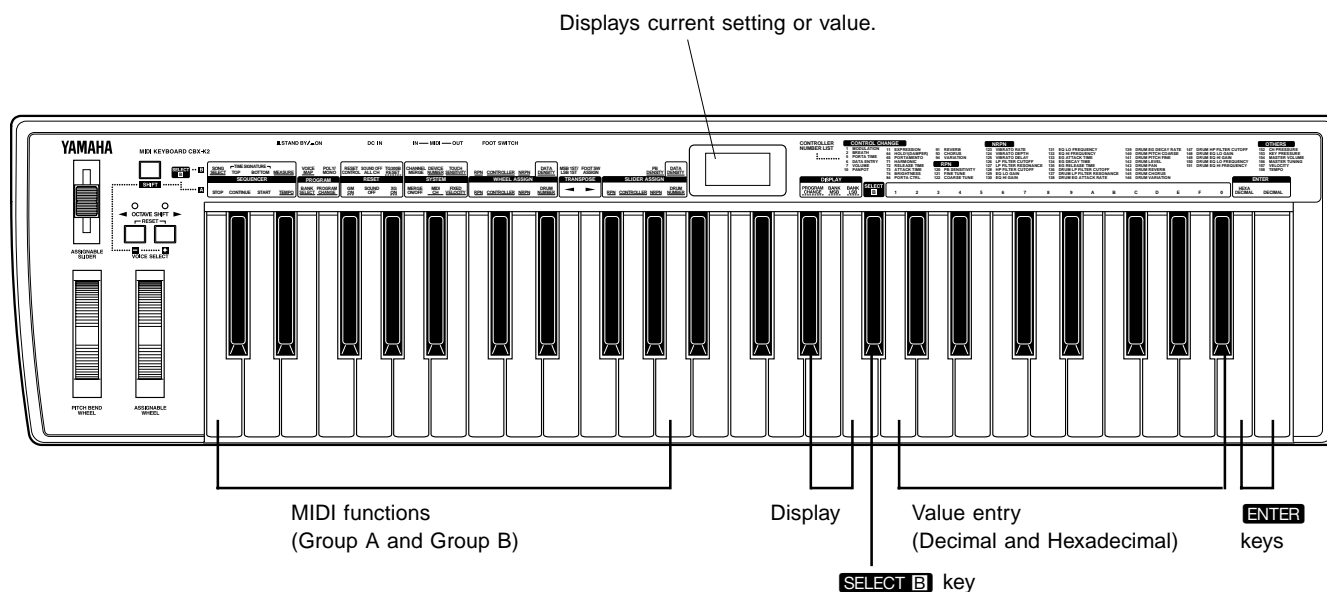

The MIDI functions can be generally divided into three types, according to their operation.

- 1) **Holding **SHIFT** and pressing the function’s key.** For these functions, such as Sequencer Stop and Start, pressing **ENTER** is not necessary. These functions are shown on the panel without underline.
- 2) **Holding **SHIFT**, pressing the function’s key and then **ENTER**.** These functions are indicated with a dashed underline on the panel (for example, GM ON and XG ON) and require pressing **ENTER** to execute.
- 3) **Holding **SHIFT**, pressing the function’s key, entering a value and then pressing **ENTER**.** These functions are indicated with an underline on the panel (for example, PROGRAM CHANGE and TEMPO), and require that a value (Decimal or Hexadecimal) be entered.

When changing a function, the LED display indicates the on/off status or the value of the function.

In using the SHIFT-related functions, remember

Keep holding down **SHIFT** until the end of the operation. If **SHIFT** is released in mid-operation, you’ll have to start the operation all over again.

In the instructions that follow, “**ENTER**” refers to either of the **ENTER** keys, **HEXADECIMAL** or **DECIMAL**. In other words, this means that either key can be used, unless indicated otherwise.

NOTE ■ Both **◀OCTAVE SHIFT / OCTAVE SHIFT▶** lamps flash briefly when a function is executed. The LED display flashes briefly when a MIDI message is sent.

Basic Operations

Selecting Group A and Group B Functions

● Selecting Group A Functions:

Hold down **SHIFT** and press the appropriate key. (See on pages 26 – 27 for specific Group A functions and how to use them.)

● Selecting Group B Functions:

Hold down **SHIFT** and press **SELECT B**. The Group B functions are available as long as you continue to hold down **SHIFT**. (See on pages 28 – 29 for specific Group B functions and how to use them.)

Entering Values

Value entry on the CBX-K2 can be done in two number systems: Decimal and Hexadecimal. The keys labeled A through F are for Hexadecimal entry.

● Entering a decimal value:

Hold down **SHIFT**, press the appropriate function key, enter the desired value in decimal format, then press **DECIMAL**.

● Entering a hexadecimal value:

Hold down **SHIFT**, press the appropriate function key, enter the desired value in hexadecimal format, then press **HEXADECIMAL**.

Example — Setting the MIDI Transmit Channel to 12:

Decimal:

SHIFT + **MIDI CH** → 1 → 2 → **DECIMAL**

Hexadecimal:

SHIFT + **MIDI CH** → C → **HEXADECIMAL**

* Also see the **Decimal-Hexadecimal Conversion Chart** on page 33.)

Value Entry — Some Specific Examples and Anomalies

● Entering MSB/LSB Values with **DECIMAL** (3 digit bytes for MSB, 3 digit bytes for LSB; 6 digits total message). For messages beginning with zeroes, the first zeroes can be omitted.

Examples:

* 3 → **DECIMAL**: results in a value of MSB = 000, LSB = 003.

* 0 → 3 → **DECIMAL**: results in a value of MSB = 000, LSB = 003.

* 1 → 0 → 0 → 3 → **DECIMAL**: results in a value of MSB = 001, LSB = 003.

* 0 → 1 → 0 → 0 → 3 → **DECIMAL**: results in a value of MSB = 001, LSB = 003.

● Entering MSB/LSB Values with **HEXADECIMAL** (2 digit bytes for MSB, 2 digit bytes for LSB; 4 digits total message). For messages beginning with zeroes, the first zeroes can be omitted.

Examples:

* 3 → **HEXADECIMAL**: results in a value of MSB = 00, LSB = 03.

* 0 → 3 → **HEXADECIMAL**: results in a value of MSB = 00, LSB = 03.

* 1 → 0 → 3 → **HEXADECIMAL**: results in a value of MSB = 01, LSB = 03.

* 0 → 1 → 0 → 3 → **HEXADECIMAL**: results in a value of MSB = 01, LSB = 03.

When entering MSB and LSB values, the LED display alternately flashes the MSB and LSB values in hexadecimal or decimal form.

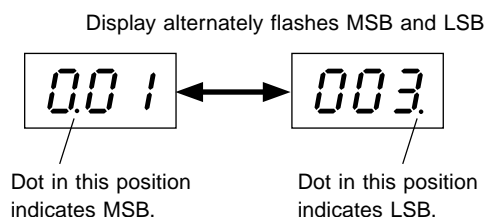

NOTE ■ The order of MSB and LSB entry can be reversed. (See **MSB 1ST/LSB 1ST** on page 28.)

NOTES ON THE BASIC OPERATION

■ If you inadvertently press two or more function keys while performing a function, the last pressed key has priority.

■ If, after entering a value, you press another function key before pressing **ENTER**, the value will be cancelled.

■ If you enter a value that is outside of a function's range, it will be ignored. Legal messages can be one byte in length (a value from 0 – 255) exception for **Tempo value** and **Measure Number**.

Setting the Functions

This section shows by example the operations for the basic functions.

* Unless indicated otherwise, **ENTER** refers to either of the **ENTER** keys, **HEXADECIMAL** or **DECIMAL**. How-

ever, when you wish to enter a decimal value, make sure to press **DECIMAL**. Likewise, when entering a hexadecimal number, make sure to press **HEXADECIMAL**.

Group A Operations

Group A function names are shown on the panel above the corresponding keys. For the list and explanations of Group A functions, refer to pages 26 – 27.

● Numbers **1** – **3** in the illustration correspond to the operation numbers below.

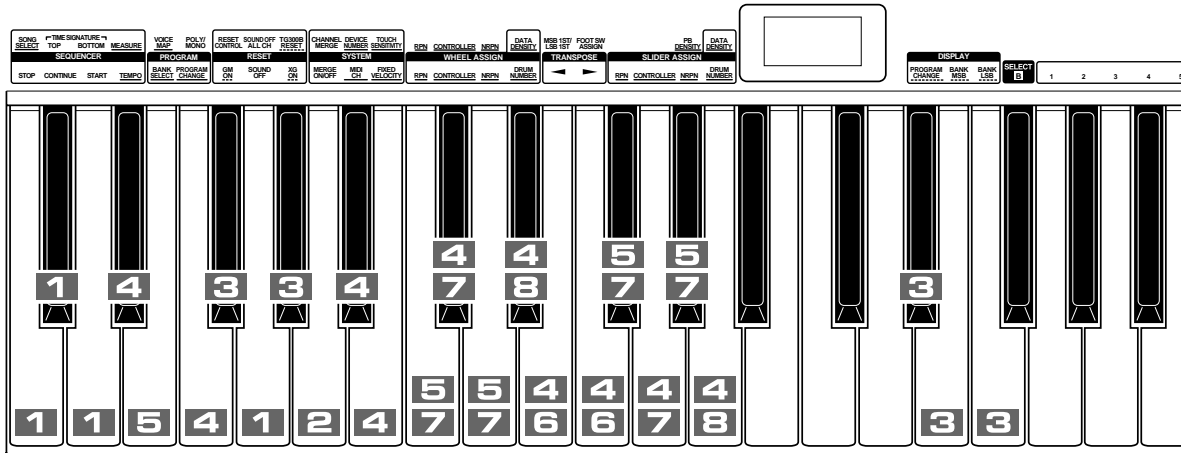

1 Sending a Simple Command

1

Operation: **SHIFT** + Function Key
 Relevant Functions: Sequencer Stop/Continue/Start; Sound Off

● **Example:** Sending a Start command to a sequencer or rhythm machine

SHIFT + **START**

You can use the **STOP** and **CONTINUE** keys in the same way, to stop the sequencer or continue playback from the stopped point.

2 Setting a Simple Command (on/off)

2

Operation: **SHIFT** + Function Key
 Relevant Functions: Merge On/Off

● **Example:** Switching the MIDI Merge function of the CBX-K2 on or off

SHIFT + **MERGE ON/OFF**

3 Setting a Simple Command with **ENTER**

3

Operation: **SHIFT** + Function Key → **ENTER**
 Relevant Functions: GM Mode On; XG System On; Display

● **Example:** Setting the tone generator to XG Mode

SHIFT + **XG ON** → **ENTER**

NOTE ■ Either **ENTER** key can be used for these commands.

4 Setting a Specific Value for a Function

4

Operation: **SHIFT** + Function Key → Value → **ENTER**
 Relevant Functions: Tempo; Program Change; MIDI Channel; Fixed Velocity; Controller; Drum Number; Transpose Down/Up

● **Example:** Changing the tempo value on a sequencer or rhythm machine

SHIFT + **TEMPO** → **1** → **4** → **0** → **DECIMAL**

5

Setting a Specific Value for a Function (MSB, LSB)

Operation: **SHIFT** + Function Key → MSB value → LSB value → **ENTER**

Relevant Functions: Bank Select; RPN; NRPN

- **Example:** This example shows how to use the Bank Select function to select different banks. This example also shows you how to use the functions that require entry of two values: MSB and LSB.

In this example, we'll enter a value of 012 (MSB) 034 (LSB)

SHIFT + **BANK SELECT** → 0 → 1 → 2 → 0 → 3

→ 4 → **DECIMAL**

SHIFT + **BANK SELECT** → 0 → C → 2 → 2 →

HEXADECIMAL

NOTE ■ Decimal values of MSB and LSB are 3 digits each (6 digits total); hexadecimal values are 2 digits each. Zeroes must be entered, unless they occur at the beginning of the value. For example, for the decimal value of 001 (MSB) 012 (LSB), the first two zeroes may be omitted, but the third must be entered. In other words, the value could be entered as 1 → 0 → 1 → 2.

6

Transpose Setting

Operation: **SHIFT** + **TRANSPOSE** ◀ / **TRANSPOSE** ▶

To transpose up one semitone, use the **TRANSPOSE** ▶ key (F2). To transpose down one semitone, use the **TRANSPOSE** ◀ key (E2). Each repeated pressing of the key while holding **SHIFT** transposes the pitch by an additional semitone. To restore the normal default transpose setting, hold down **SHIFT** and press both **TRANSPOSE** ◀ / **TRANSPOSE** ▶ keys simultaneously.

NOTE ■ You can also enter transpose values directly by using operation 4 above.

7

Setting a Specific Value for a Specific Controller

Operation: **SHIFT** + Function Key → Controller Number → **ENTER** → {Value(s) → **ENTER**}

Relevant Functions: RPN*; Controller; NRPN*

Functions marked with an asterisk (*) above require that you enter two values: an MSB (Most Significant Byte) and an LSB (Least Significant Byte). (See operation 5, this page.)

- **Example:** Changing the Portamento Time to 25.

SHIFT + **CONTROLLER** → 5 (Portamento Time) → **ENTER** →

{ 2 → 5 → **ENTER** }

The operation steps enclosed in braces ({}) can be repeated or re-entered as long as **SHIFT** is held.

NOTE ■ This operation assigns a controller number for the Assignable Wheel or Slider, **and** sends a specific value for that controller number. You can also send a specific value for the controller (in the Group B functions) **without** altering the controller assignment.

8

Selecting a Drum Number (when editing a specific drum number with controller numbers 136 – 151)

You can use operation 4 above to set the drum number for editing a specific drum number with controller numbers 136 – 151. However, the following operation lets you set the Drum number by playing it from the keyboard. This allows you to hear the drum sound you'll be editing, since the last note played on the keyboard determines the drum sound to be changed.

Without pressing **SHIFT**, find the desired drum number by sound — by pressing keys on the keyboard. Next, hold down **SHIFT**, press **DRUM NUMBER**, then **ENTER**. This sets the drum number to the last key pressed. Then (to set the controller number for that drum sound), hold down **SHIFT** and press **CONTROLLER**, then enter the controller number (136 through 151). This sets the Controller Number for the Drum parameter you wish to control with the Assignable Wheel or Slider.

Setting the Functions

* Unless indicated otherwise, **ENTER** refers to either of the **ENTER** keys, **HEXADECIMAL** or **DECIMAL**. However, when you wish to enter a decimal value, make sure

to press **DECIMAL**. Likewise, when entering a hexadecimal number, make sure to press **HEXADECIMAL**.

Group B Operations

Group B function names are also shown on the panel above the Group A function names. For the list and explanations of Group B functions, refer to pages 28 – 29.

● Numbers **9** – **14** in the illustration correspond to the operation numbers below.

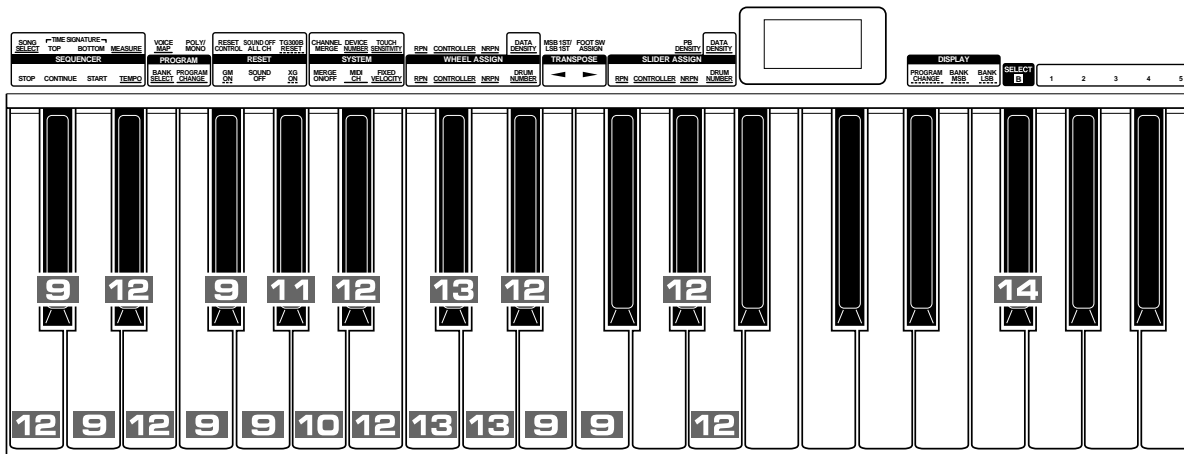

9 Sending a Simple Command

Operation: **SHIFT** + **SELECT B** → Function Key

Relevant Functions: Time Signature Top*; Time Signature Bottom*; Poly/Mono; Reset Control; Sound Off (all channels); MSB/LSB Invert; Footswitch Assign*

* Repeatedly press function key to select the various values/settings for these functions.

● **Example:** Sending a Reset All Controllers command to a sequencer or tone generator

SHIFT + **SELECT B** → **RESET CONTROL**

10 Setting a Simple Command (on/off)

Operation: **SHIFT** + **SELECT B** → Function Key → Value
Relevant Function: Merge On/Off (each channel)

● **Example:** Switching the MIDI Merge function of the CBX-K2 on or off for MIDI channel 12

SHIFT + **SELECT B** → **CHANNEL MERGE** → **C** (hexadecimal for MIDI channel 12)

Keys **1** – **F** and **0** correspond to MIDI channel 1–15 and 16, respectively. Pressing each key toggles the on/off status of each channel.

11

Sending a Simple Command with **ENTER**

Operation: **SHIFT** + **SELECT B** → Function Key → **ENTER**
 Relevant Function: TG300B Reset

- **Example:** Sending the current CBX-K2 settings to a MIDI storage device or sequencer with the Bulk Dump Out function
SHIFT + **SELECT B** → **TG300B RESET** → **ENTER**

12

Setting a Specific Value for a Function

Operation: **SHIFT** + **SELECT B** → Function Key → Value → **ENTER**
 Relevant Functions: Song Select; Voice Map; Device Number; Touch Sensitivity; Data Density (Wheel); PB Density; Data Density (Slider); Measure Number

- **Example:** Changing the touch sensitivity of the CBX-K2 to 10
SHIFT + **SELECT B** → **TOUCH SENSITIVITY** → **1** → **0** → **DECIMAL**

13

Setting a Specific Value for a Specific Controller

Operation: **SHIFT** + **SELECT B** → Function Key → Controller Number → **ENTER** → {Value(s) → **ENTER**}
 Relevant Functions: RPN Direct Data Send*; Controller Direct Data Send; NRPN Direct Data Send*
 Functions marked with an asterisk (*) above require that you enter two values: an MSB (Most Significant Byte) and an LSB (Least Significant Byte). (See on page 21 and operation **5**, page 23.)

- **Example:** Changing the Portamento Time of the tone generator's voice to 25.
SHIFT + **SELECT B** → **CONTROLLER** → **5** (Portamento Time) → **DECIMAL** → {**2** → **5** → **DECIMAL**}

The operation steps enclosed in braces ({}) can be repeated or re-entered as long as **SHIFT** is held.

NOTE ■ This operation transmits a value for the specified controller number *WITHOUT* altering the current controller assignment for the Assignable Wheel or Assignable Slider.

NOTE ■ Decimal values of MSB and LSB are 3 digits each (6 digits total); hexadecimal values are 2 digits each. Zeroes must be entered, unless they occur at the beginning of the value. For an example of MSB = 012, LSB = 034 above, the first zero may be omitted, but the second must be entered. In other words, the value could be entered as **1** → **2** → **0** → **3** → **4** → **DECIMAL**.

14

Sending a Single-Byte Data Message

This function allows you to quickly and easily send a non-standard MIDI message of a single byte. The effective range of this function is from 0–255; values outside of this range will be ignored.

Operation: **SHIFT** + **SELECT B** → {Value → **ENTER**}

- **Example:** Sending a (decimal) value of 252
SHIFT + **SELECT B** → {**2** → **5** → **2** → **DECIMAL**}

The operation steps enclosed in braces ({}) can be repeated or re-entered as long as **SHIFT** is held.

Group A Functions — List

Key	Panel Name	Function name	Operation (press and hold [SHIFT])	*1	Operation Examples
C1	SEQUENCER	STOP	Stop	SHIFT + STOP	1
C#1		CONTINUE	Continue	SHIFT + CONTINUE	1
D1		START	Start	SHIFT + START	1
D#1		TEMPO	Tempo	SHIFT + TEMPO → (tempo value) → ENTER	4
E1	PROGRAM	BANK SELECT	Bank Select	SHIFT + BANK SELECT → (MSB) → (LSB) → ENTER	5
F1		PROGRAM CHANGE	Program Change	SHIFT + PROGRAM CHANGE → (program change number) → ENTER	4
F#1	RESET	GM ON	GM System On	SHIFT + GM ON → ENTER	3
G1		ALL SOUND OFF	All Sound Off (current channel)	SHIFT + SOUND OFF	1
G#1		XG ON	XG System On	SHIFT + XG ON → ENTER	3
A1	SYSTEM	MERGE ON/OFF	Merge On/Off(all channel)	SHIFT + MERGE ON/OFF	2
A#1		MIDI CH	MIDI Transmit channel	SHIFT + MIDI CH → (channel number) → ENTER	4
B1		FIXED VELOCITY	Fixed Velocity	SHIFT + FIXED VELOCITY → (velocity value) → ENTER	4
C2	WHEEL ASSIGN	RPN	Wheel Assign (RPN)	SHIFT + RPN → (MSB) → (LSB) → ENTER	5 7
C#2		CONTROLLER	Wheel Assign (controller number)	SHIFT + CONTROLLER → (controller number) → ENTER	4 7
D2		NRPN	Wheel Assign (NRPN)	SHIFT + NRPN → (MSB) → (LSB) → ENTER	5 7
D#2		DRUM NUMBER	Drum Number (Wheel)	Select the desired drum sound from the keyboard (page 23) then press SHIFT + DRUM NUMBER → ENTER	8 4
E2	TRANPOSE	◀	Transpose Down	SHIFT + TRANPOSE ◀ → { TRANPOSE ◀} → ... (press repeatedly)	6 4
F2		▶	Transpose Up	SHIFT + TRANPOSE ▶ → { TRANPOSE ▶} → ... (press repeatedly)	6 4
F#2	SLIDER ASSIGN	RPN	Slider Assign (RPN)	SHIFT + RPN → (MSB) → (LSB) → ENTER	5 7
G2		CONTROLLER	Slider Assign (controller number)	SHIFT + CONTROLLER → (controller number) → ENTER	4 7
G#2		NRPN	Slider Assign (NRPN)	SHIFT + NRPN → (MSB) → (LSB) → ENTER	5 7
A2		DRUM NUMBER	Drum Number (Slider)	Select the desired drum sound from the keyboard (page 23) then press SHIFT + DRUM NUMBER → ENTER	8 4
D#3	DISPLAY	PROGRAM CHANGE	Display Program Change	SHIFT + PROGRAM CHANGE → ENTER	3
E3		BANK MSB	Display Bank Select MSB	SHIFT + BANK MSB → ENTER	3
F3		BANK LSB	Display Bank Select LSB	SHIFT + BANK LSB → ENTER	3

● Footnotes

- *1 The operation steps in braces ({}) can be repeated or re-entered as long as **SHIFT** is held.
- *2 Depending on the selected message or the particular device that is connected to the CBX-K2, there may be no response. Refer to the owner's manual of the device for details.
- *3 Be careful not to press the connected footswitch when footswitch is assigned to "5U5"; the operation cannot be executed while the footswitch is pressed.
- *4 When Tempo is assigned to the Assignable Wheel or Slider, this setting is ignored. When the Assignable Wheel or Slider is set to a

function other than Tempo, the current value is effective. The range for this function is 20 – 300 bpm; when the Wheel or Slider is set to control Tempo, the range is slightly narrower: 28 – 282 bpm. When this is set to 0, "oFF" is shown in the display.

- *5 The entry order of the MSB and LSB values can be changed by using the MSB 1ST/LSB 1ST in Group B.
- *6 The actual program change number transmitted by the CBX-K2 is the displayed number minus one. For example, program number 001 on the display is actually transmitted as 000.
- *7 The value can also be easily increased or decreased. First, make sure that the display is set appropriately (to Program Change or Bank

Group A Functions — List

Explanation	Range (Hexadecimal in parentheses)	Default setting	MIDI Code	Notes
Stop command for sequencer/rhythm machine.	-	-	<<FC>>	*2
Continue command for sequencer/rhythm machine.	-	-	<<FB>>	*2
Start command for sequencer/rhythm machine.	-	-	<<FA>>	*2
Tempo entry for sequencer/rhythm machine. Setting to 0 disables the MIDI clock transmission. When Assignable Wheel or Slider is set to Tempo (158), this is inactive.	0, 20-300(0, 14-12C)	0(<i>oFF</i>)	<<F8>>	*2, *4
This allows selection of voice banks on tone generators that support multiple banks. This message must include both MSB and LSB values.	MSB:000-127(00-7F) LSB:000-127(00-7F)	MSB:000 LSB:000	<<Bn 00 msb, Bn 20 LSB, Cn pp>>	*5, *7
Transmits the selected program change number. Stepping up or down through program numbers is also possible by holding down SHIFT and using the ◀OCTAVE SHIFT/ OCTAVE SHIFT▶ buttons (page 16).	1-128(1-80)	1	<<Cn pp>>	*6, *7
This resets the connected tone generator to GM operation. Caution: Be careful when using this, since it automatically changes whatever settings you've made on the tone generator. (Only GM compatible tone generators respond to this message.)	-	-	<<F0 7E 7F 09 01 F7>>	*8
This turns all sounds off over the current MIDI channels. To turn all sounds off for all MIDI channel, use All Sounds Off in Group B.	-	-	<<Bn 78 00>>	
This resets the connected tone generator to XG operation. Caution: Be careful when using this, since it automatically changes whatever settings you've made on the tone generator. (Only XG compatible tone generators respond to this message.)	-	-	<<F0 43 1s 4C 00 00 7E 00 F7>>	*8
When set to ON, this merges all data received at MIDI IN with the data generated by the CBX-K2. Merge can be set independently for each channel in the Group B. (For details about MIDI Merge, refer to page 34.)	<i>on, oFF</i>	<i>on</i>	-	*9
This determines the MIDI transmit channel for the CBX-K2. This should be set to match the MIDI receive channel of the connected MIDI device.	1-16(1-10)	1	-	*3
This sets a fixed velocity value for the keyboard; in other words, playing the keyboard at any strength results in a certain velocity value. When this is set to 0 or "oFF"(initial touch on), Touch sensitivity can be set in the Group B. When the Assignable Wheel or Slider is set to Velocity(157), this is inactive.	0, 1-127(0, 1-7F)	0(<i>oFF</i>)	-	
This determines the RPN (Registered Parameter Number) controller for the Assignable Wheel. The message must include both MSB and LSB values.	MSB:000-127(00-7F) LSB:000-127(00-7F)	-	<<Bn 64 LSB, Bn 65 MSB, Bn 06 vv>> Refer to the Controller list on page 30.	*5, *10
This determines the Controller number for the Assignable Wheel. Though not all are listed on the panel, any of the standard Control Change numbers (0 - 119) can be assigned. (For a complete list of the available controllers and their numbers, see on page 30.)	0-158(0-9E)	1	<<Bn gg vv>>etc.. Refer to the Controller list on page 30.	*10
This determines the controller by using NRPN (Non-Registered Parameter Number) for the Assignable Wheel. Refer to the Controller list on page 30. The message must include both MSB and LSB values.	MSB:000-127(00-7F) LSB:000-127(00-7F)	-	<<Bn 62 LSB, Bn 63 MSB, Bn 06 vv>> Refer to the Controller list on page 30.	*5, *10
This determines the drum number for use with the Wheel and the assigned drum-related control number (136 - 151). The following alternate operation can also be used: SHIFT + [DRUM NUMBER] → [note number (of desired drum sound)] → ENTER	0-127(00-7F)	0	-	
This lowers the key transposition by the specified amount (in semitones).	0-12(0-C)	0	-	*11
This raises the key transposition by the specified amount (in semitones).	0-12(0-C)	0	-	*11
This determines the RPN (Registered Parameter Number) controller for the Assignable Slider. The message must include both MSB and LSB values.	MSB:000-127(00-7F) LSB:000-127(00-7F)	-	<<Bn 64 lsb, Bn 65 msb, Bn 06 vv>> Refer to the Controller list on page 30.	*5, *10
This determines the Controller number for the Assignable Slider. Though not all are listed on the panel, any of the standard Control Change numbers (0-119) can be assigned. (For a complete list of the available controllers and their numbers, see on page 30.)	0-158(0-9E)	6	<<Bn gg vv>>etc.. Refer to the Controller list on page 30.	*10
This determines the NRPN (Non-Registered Parameter Number) controller for the Assignable Slider. The message must include both MSB and LSB values. (Refer to the Controller list on page 30.)	MSB:000-127(00-7F) LSB:000-127(00-7F)	-	<<Bn 62 lsb, Bn 63 msb, Bn 06 vv>> Refer to the Controller list on page 30.	*5, *10
This determines the drum number for use with the Slider and the assigned drum-related control number (136 - 151). The following alternate operation can also be used: SHIFT + [DRUM NUMBER] → [note number (of desired drum sound)] → ENTER	0-127(00-7F)	0	-	
Changes the LED display to show the currently selected program number.	Toggles among the three settings.	When power is turned on Program Change is selected.	-	
Changes the LED display to show the currently selected Bank Select MSB value.			-	
Changes the LED display to show the currently selected Bank Select LSB value.			-	

Select MSB/LSB; see corresponding Group A functions). Then, hold down **SHIFT** and press the **◀OCTAVE SHIFT** or **OCTAVE SHIFT▶** button. (Hold down the appropriate button to change the value continuously.) To directly change the value (decimal or hexadecimal) for the displayed function, hold down **SHIFT**, enter the value, then press **ENTER**.

- *8 The connected device initializes itself upon reception of this message.
- *9 When a MIDI error results, MIDI Merge is automatically set to OFF.
- *10 • When RPN or NRPN is assigned, the Wheel or Slider is automatically set to control Data Entry and will change the relevant parameter on the connected device.

- To send a specific value for the current control number assignment of the Wheel or Slider, hold down **SHIFT**, enter the desired value, and press **ENTER**. However, this cannot be done with the following controller numbers: 153 (Key Pressure), 157 (Velocity), or 158 (Tempo).
- The assigned MSB and LSB values alternately appear in the LED display. When no value is assigned, "--" is shown in the display.
- *11 Transpose can be done in two ways: by repeatedly pressing **TRANPOSE◀** or **TRANPOSE▶** key or by entering the transpose value directly after pressing **TRANPOSE◀** or **TRANPOSE▶** key. To restore the normal transpose setting, hold **SHIFT** and press both **TRANPOSE** keys simultaneously.

Group B Functions — List

Key	Panel Name	Function name	Operation (press and hold [SHIFT])	Operation Examples
C1	SEQUENCER	SONG SELECT	Song Select [SHIFT] + [SELECT B] → [SONG SELECT] → (song number) → [ENTER]	12
C#1		TIME SIGNATURE TOP	Time Signature Top (numerator) [SHIFT] + [SELECT B] → {[TOP]}...(press repeatedly)	9
D1		TIME SIGNATURE BOTTOM	Time Signature Bottom (denominator) [SHIFT] + [SELECT B] → {[BOTTOM]}...(press repeatedly)	9
D#1		MEASURE	Measure Number [SHIFT] + [SELECT B] → [MEASURE] → (measure number) → [ENTER]	12
E1	-	VOICE MAP	Voice Map [SHIFT] + [SELECT B] → [VOICE MAP] → (Map number) → [ENTER]	12
F1	-	POLY/MONO	Poly/Mono [SHIFT] + [SELECT B] → [POLY/MONO]	9
F#1	RESET	RESET CONTROL	Reset All Controllers [SHIFT] + [SELECT B] → [RESET CONTROL]	9
G1		SOUND OFF ALL CH	All Sound Off (all channels) [SHIFT] + [SELECT B] → [SOUND OFF ALL CH]	9
G#1		TG300B	TG300B Reset [SHIFT] + [SELECT B] → [TG300B RESET] → [ENTER]	11
A1	SYSTEM	CHANNEL MERGE	Merge On /Off (each channel) [SHIFT] + [SELECT B] → [CHANNEL MERGE] → (channel number)	10
A#1		DEVICE NUMBER	Device Number [SHIFT] + [SELECT B] → [DEVICE NUMBER] → (device number) → [ENTER]	12
B1		TOUCH SENSITIVITY	Touch Sensitivity [SHIFT] + [SELECT B] → [TOUCH SENSITIVITY] → (value) → [ENTER]	12
C2	-	RPN	Controller Direct Data Send (RPN) [SHIFT] + [SELECT B] → [RPN] → (MSB) → (LSB) → [ENTER] → ((control value) → [ENTER])	13 *9
C#2	-	CONTROLLER	Controller Direct data Send (controller number) [SHIFT] + [SELECT B] → [CONTROLLER] → (controller number) → [ENTER] → ((controller value) → [ENTER])	13 *9
D2	-	NRPN	Controller Direct Data Send (NRPN) [SHIFT] + [SELECT B] → [NRPN] → (MSB) → (LSB) → [ENTER] → ((controller value) → [ENTER])	13 *9
D#2	WHEEL ASSIGN	DATA DENSITY	Data Density (Wheel) [SHIFT] + [SELECT B] → [DATA DENSITY] → (density value) → [ENTER]	12
E2	-	MSB 1ST/LSB 1ST	MSB/LSB invert [SHIFT] + [SELECT B] → [MSB 1ST/LSB 1ST]	9
F2	-	FOOT SW ASSIGN	Footswitch Assign [SHIFT] + [SELECT B] → {[FOOT SW ASSIGN]} ... (press repeatedly)	9
F#2	-	-	-	-
G2	-	-	-	-
G#2	-	PB DENSITY	Data Density (Pitch Bend Wheel) [SHIFT] + [SELECT B] → [PB DENSITY] → (density value) → [ENTER]	12
A2	SLIDER ASSIGN	DATA DENSITY	Data Density (Slider) [SHIFT] + [SELECT B] → [DATA DENSITY] → (density value) → [ENTER]	12
F#3	-	SELECT B	Single-byte Data Send [SHIFT] + [SELECT B] → ((single-byte data) → [ENTER])	*9 14

● Footnotes

- *1 Depending on the selected message or the particular device that is connected to the CBX-K2, there may be no response. Refer to the owner's manual of the device for details.
- *2 The Time Signature Top value is selected in the following order: 4, 5, 6, ... 15, 16, 1, 2, 3, 4, etc. ("4" is used as the starting point, since that is the most commonly used Top value.) The order for the Time Signature Bottom values is 4, 8, 16, 4, etc.
- *3 The range for the Measure function depends on the currently set Time Signature. When set to 4/4, the range is 1 – 999; when set to 8/4 or 16/8, the range is 1 – 512. The absolute maximum is 999.

- *4 • The channel number can only be entered as a hexadecimal value (1 – F, 0).
- Using system exclusive messages to turn Merge on or off can only be done for all channels (as in the corresponding Group A function).
- *5 When Fixed Velocity (in Group A) is set to a value other than 0, the Touch Sensitivity function is inactive. The following table shows the velocity range for the minimum, medium, and maximum Touch Sensitivity settings.

Group B Functions — List

Explanation	Range (Hexadecimal in parentheses)	Default setting	MIDI Code	Notes
Song Select command for sequencer/rhythm machine.	0-127(00-7F)	0	<<F3 ss>>	*1
This determines the top (numerator) value of the time signature for sequencer/rhythm machine, at the specified song position (see Measure Number below). When song position is received this data will be used.	1-16	4	-	*2
This determines the bottom (denominator) value of the time signature for sequencer/rhythm machine, at the specified song position (see Measure Number below). When song position is received this data will be used.	4, 8, 16	4	-	*2
This determines the measure number (song position) for sequencer/rhythm machine. This is used together with the Time Signature functions above, and should be entered before specifying the Time Signature.	1-999(1-3E7) (depending on specified Time Signature)	1	<<F2 lsb msb>>	*1, *3
This determines the Voice Map setting when used with the Yamaha MU100R Tone Generator. (For details, see the MU100R Owner's Manual.)	0-127(00-7F)	0	<<F0 43 1s 49 00 00 12 vv>>	
Sets the connected tone generator to Poly or Mono mode.	<i>PoL, nOn</i>	<i>PoL</i>	<<Bn 7E 00>>, <<Bn 7F 00>>	
This resets all MIDI controller values on the connected device to their reset values (minimum or center).	-	-	<<Bn 79 00>>	
This turns all sounds off over all MIDI channels. To turn all sounds off for a single specific MIDI channel, use the All Sound Off function in Group A.	-	-	<<B0 78 00, B1 78 00,..., BF 78 00>>	
This performs a TG300B reset on a connected tone generator.	-	-	<<F0 41 10 42 12 40 00 7F 00 41 F7>>	
This merges all data received over the specified MIDI channel with the data generated by the CBX-K2. This function can be set independently for each channel. (For details about MIDI Merge, refer to page 34.)	<i>oN, oFF</i>	<i>oN</i>	-	*4
This determines the Device Number when independently transmitting certain messages (such as XG On) to one of several connected MIDI devices.	1-16(1-10)	1	-	
This determines the relative velocity sensitivity of the CBX-K2 keyboard. The lower the Touch Sensitivity value, the higher the output velocity becomes. In other words, when this is set to a value near 1, even soft playing strength results in a loud sound from the connected tone generator. (1: easy - 10: hard)	1-10(1-A)	10	-	*5
This allows you to directly send a specific value for a selected RPN controller number, without altering the current controller assignment of the Assignable Wheel or Slider.	MSB:000-127(00-7F) LSB:000-127(00-7F) Control value:0-127 (00-7F)	-	<<Bn 64 lsb, Bn 65 msb, Bn 06 vv>> Refer to the Controller list on page 30.	
This allows you to directly send a specific value for a selected Control Change controller number, without altering the current controller assignment of the Assignable Wheel or Slider.	Control number:0-156 (0-9C) Control value:0-127 (00-7F)	-	<<Bn gg vv>>etc.. Refer to the Controller list on page 30.	*6
This allows you to directly send a specific value for a selected NRPN controller number, without altering the current controller assignment of the Assignable Wheel or Slider.	MSB:000-127(00-7F) LSB:000-127(00-7F) Control value:0-127 (00-7F)	-	<<Bn 62 lsb, Bn 63 msb, Bn 06 vv>> Refer to the Controller list on page 30.	
This determines the density of the data sent by the Assignable Wheel when it is set to a continuous controller (such as modulation or volume). Set this to a value at or near 1, when you wish to limit the amount of data sent (for example, when sequencer memory limits the amount of data that can be recorded). (1: thin - 10: thick or full)	1-10(1-A)	10	-	
This inverts the MSB/LSB value entry (so that LSB precedes MSB). You can also set this to LSB 1ST by simultaneously holding down [OCTAVE SHIFT] and turning on the power.	MSB 1ST(MSB → LSB) LSB 1ST(LSB → MSB)	MSB precedes LSB	-	*7
This determines the function for the connected footswitch. Available functions are: Sustain (SUS), Continue/Stop for sequencer (Cnt), Start/Stop for sequencer (STA), SHIFT button operation (SFT).	<i>SUS, Cnt, StA, SFT</i>	<i>SUS</i>	-	*10
-	-	-	-	
-	-	-	-	
This determines the density of the data sent by the Pitch Bend Wheel.	1-10(1-A)	10	-	
This determines the density of the data sent by the Assignable Slider when it is set to a continuous controller (such as modulation or volume). Set this to a value at or near 1, when you wish to limit the amount of data sent (for example, when sequencer memory limits the amount of data that can be recorded). It can also be used to create special "step" effects for certain controller numbers. (1: thin - 10: thick or full)	1-10(1-A)	10	-	
This sends a data message of a single byte.	0-255(0-FF)	-	<<xx>> xx=single-byte data	*8

Touch Sensitivity Value	1 (1)	5 (5)	10 (A)
Velocity Range	32-127 (20-7F)	16-127 (10-7F)	1-127 (01-7F)

- *6 The following controller numbers cannot be used: 153 (Key Pressure), 157 (Velocity), or 158 (Tempo).
- *7 When the MSB/LSB entry order is changed, the LED display appears as follows to indicate the data order:

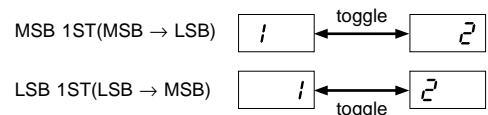

- *8 The effective range is from 0 - 255; values outside of this range will be ignored.
- *9 The operation steps in braces ({}) can be repeated or re-entered as long as [SHIFT] is held.
- *10 Be careful not to press the connected footswitch while using this function; the operation cannot be executed while the footswitch is assigned to "SFT" and pressed.

Assignable Wheel & Slider — Controller Number List

For further details on these various control numbers refer to the MIDI Data Format supplement.

No.	Controller Name	Data Format	MIDI Code	Direct Data Send Range (Hexadecimal in parentheses)
1	Modulation Depth	Control Change	<<Bn gg vv>>	000-064-127 (00-40-7F)
2	Breath Control	Control Change	<<Bn gg vv>>	000-064-127 (00-40-7F)
4	Foot Control	Control Change	<<Bn gg vv>>	000-064-127 (00-40-7F)
5	Portamento Time	Control Change	<<Bn gg vv>>	000-064-127 (00-40-7F)
6	Data Entry MSB	Control Change	<<Bn gg vv>>	000-064-127 (00-40-7F)
7	Main Volume	Control Change	<<Bn gg vv>>	000-064-127 (00-40-7F)
10	Pan	Control Change	<<Bn gg vv>>	000-064-127 (00-40-7F)
11	Expression	Control Change	<<Bn gg vv>>	000-064-127 (00-40-7F)
64	Hold 1 (Damper)	Control Change	<<Bn gg vv>>	000-064-127 (00-40-7F)
65	Portamento	Control Change	<<Bn gg vv>>	000-064-127 (00-40-7F)
66	Sostenuto (Chord Hold)	Control Change	<<Bn gg vv>>	000-064-127 (00-40-7F)
67	Soft Pedal	Control Change	<<Bn gg vv>>	000-064-127 (00-40-7F)
71	Harmonic Content	Control Change	<<Bn gg vv>>	000-064-127 (00-40-7F)
72	Release Time	Control Change	<<Bn gg vv>>	000-064-127 (00-40-7F)
73	Attack Time	Control Change	<<Bn gg vv>>	000-064-127 (00-40-7F)
74	Brightness	Control Change	<<Bn gg vv>>	000-064-127 (00-40-7F)
84	Portamento Control	Control Change	<<Bn gg vv>>	000-064-127 (00-40-7F)
91	Reverb Send Level	Control Change	<<Bn gg vv>>	000-064-127 (00-40-7F)
93	Chorus Send Level	Control Change	<<Bn gg vv>>	000-064-127 (00-40-7F)
94	Variation Effect Send Level	Control Change	<<Bn gg vv>>	000-064-127 (00-40-7F)
120	Pitch Bend Sensitivity	RPN	<<Bn 64 00, Bn 65 00, Bn 06 vv>>	000-064-127 (00-40-7F)
121	Fine Tuning	RPN	<<Bn 64 01, Bn 65 00, Bn 06 vv>>	000-064-127 (00-40-7F)
122	Coarse Tuning	RPN	<<Bn 64 02, Bn 65 00, Bn 06 vv>>	000-064-127 (00-40-7F)
123	Vibrato Rate	NRPN	<<Bn 62 08, Bn 63 01, Bn 06 vv>>	000-064-127 (00-40-7F)
124	Vibrato Depth	NRPN	<<Bn 62 09, Bn 63 01, Bn 06 vv>>	000-064-127 (00-40-7F)
125	Vibrato Delay	NRPN	<<Bn 62 0A, Bn 63 01, Bn 06 vv>>	000-064-127 (00-40-7F)
126	Low Pass Filter Cutoff Frequency	NRPN	<<Bn 62 20, Bn 63 01, Bn 06 vv>>	000-064-127 (00-40-7F)
127	Low Pass Filter Resonance	NRPN	<<Bn 62 21, Bn 63 01, Bn 06 vv>>	000-064-127 (00-40-7F)
128	High Pass Filter Cutoff Frequency	NRPN	<<Bn 62 24, Bn 63 01, Bn 06 vv>>	000-064-127 (00-40-7F)
129	EQ Low Gain	NRPN	<<Bn 62 30, Bn 63 01, Bn 06 vv>>	000-064-127 (00-40-7F)
130	EQ High Gain	NRPN	<<Bn 62 31, Bn 63 01, Bn 06 vv>>	000-064-127 (00-40-7F)
131	EQ Low Frequency	NRPN	<<Bn 62 34, Bn 63 01, Bn 06 vv>>	000-064-127 (00-40-7F)
132	EQ High Frequency	NRPN	<<Bn 62 35, Bn 63 01, Bn 06 vv>>	000-064-127 (00-40-7F)
133	EG Attack Time	NRPN	<<Bn 62 63, Bn 63 01, Bn 06 vv>>	000-064-127 (00-40-7F)
134	EG Decay Time	NRPN	<<Bn 62 64, Bn 63 01, Bn 06 vv>>	000-064-127 (00-40-7F)
135	EG Release Time	NRPN	<<Bn 62 66, Bn 63 01, Bn 06 vv>>	000-064-127 (00-40-7F)
136	Drum Low Pass Filter Cutoff Frequency	NRPN	<<Bn 62 rr, Bn 63 14, Bn 06 vv>>	000-064-127 (00-40-7F)
137	Drum Low Pass Filter Resonance	NRPN	<<Bn 62 rr, Bn 63 15, Bn 06 vv>>	000-064-127 (00-40-7F)
138	Drum EG Attack Rate	NRPN	<<Bn 62 rr, Bn 63 16, Bn 06 vv>>	000-064-127 (00-40-7F)
139	Drum EG Decay Rate	NRPN	<<Bn 62 rr, Bn 63 17, Bn 06 vv>>	000-064-127 (00-40-7F)
140	Drum Pitch Coarse	NRPN	<<Bn 62 rr, Bn 63 18, Bn 06 vv>>	000-064-127 (00-40-7F)
141	Drum Pitch Fine	NRPN	<<Bn 62 rr, Bn 63 19, Bn 06 vv>>	000-064-127 (00-40-7F)
142	Drum Level	NRPN	<<Bn 62 rr, Bn 63 1A, Bn 06 vv>>	000-064-127 (00-40-7F)
143	Drum Pan	NRPN	<<Bn 62 rr, Bn 63 1C, Bn 06 vv>>	000-064-127 (00-40-7F)
144	Drum Reverb Send Level	NRPN	<<Bn 62 rr, Bn 63 1D, Bn 06 vv>>	000-064-127 (00-40-7F)
145	Drum Chorus Send Level	NRPN	<<Bn 62 rr, Bn 63 1E, Bn 06 vv>>	000-064-127 (00-40-7F)
146	Drum Variation Send Level	NRPN	<<Bn 62 rr, Bn 63 1F, Bn 06 vv>>	000-064-127 (00-40-7F)
147	Drum High Pass Filter Cutoff Frequency	NRPN	<<Bn 62 rr, Bn 63 24, Bn 06 vv>>	000-064-127 (00-40-7F)
148	Drum EQ Low Gain	NRPN	<<Bn 62 rr, Bn 63 30, Bn 06 vv>>	000-064-127 (00-40-7F)
149	Drum EQ High Gain	NRPN	<<Bn 62 rr, Bn 63 31, Bn 06 vv>>	000-064-127 (00-40-7F)
150	Drum EQ Low Frequency	NRPN	<<Bn 62 rr, Bn 63 34, Bn 06 vv>>	000-064-127 (00-40-7F)
151	Drum EQ High Frequency	NRPN	<<Bn 62 rr, Bn 63 35, Bn 06 vv>>	000-064-127 (00-40-7F)
152	Channel Pressure	After Touch	<<Dn vv>>	000-064-127 (00-40-7F)
153	Polyphonic Key Pressure	After Touch	<<An tt vv>>	— *1
154	Master Volume	System Exclusive Messages	<<F0 7F 7F 04 01 ll mm F7>>	000-064-127 (00-40-7F)
155	Master Balance	System Exclusive Messages	<<F0 7F 7F 04 02 ll mm F7>>	000-064-127 (00-40-7F)
156	Master Tuning	System Exclusive Messages	<<F0 43 1s 27 30 00 00 pm pl 00 F7>>	014-064-114 (0E-40-72) *2
157	Velocity	Others	*4	—
158	Tempo	Others	*5	— *3

● MIDI Code abbreviation key

- n: MIDI channel
- gg: Control number
- tt: Note number
- s: Device number
- rr: Drum number
- vv: 8-bit resolution of the Wheel movement or Slider (range: 00–7F)
- ll mm: 16-bit resolution of the Wheel movement or Slider (range: 0000–7FFF)
- pm pl: Wheel movement or Slider data of 8-bit values are divided into two bytes (with *pm* = upper half of 8 bits and *pl* = lower half of 8 bits), converting 1-byte data into 2-byte data, each consisting of 4 bits. The upper 4 digits are given values of 0 for both *pm* and *pl*.

● NOTE

Even though not all of the numbers are listed here, the Assignable Wheel and Slider can be assigned to any of the standard Control Change numbers: 0–119.

● Footnotes

- *1 This applies only to the highest note played. This control number is unrelated to polyphonic key pressure after touch in the MIDI standard.
- *2 Data from 00–0D is converted to a value of 0E, and data from 73–7F is converted to a value of 72.
- *3 When Tempo is assigned to the Assignable Wheel or Slider, the range becomes 28–282.
- *4 This does not output MIDI code directly, but changes the velocity of the subsequently played notes.
- *5 This does not output MIDI code directly, but changes the time interval between transmitted MIDI clocks.

About MIDI

MIDI is an acronym that stands for Musical Instrument Digital Interface, which allows electronic musical instruments to communicate with each other, by sending and receiving compatible Note, Control Change, Program Change and various other types of MIDI data, or messages. The CBX-K2 can control a MIDI device by transmitting note related data and various types of controller data.

MIDI Messages Transmitted by the CBX-K2

MIDI messages can be divided into two groups: Channel messages and System messages. Below is an explanation of the various types of MIDI messages which the CBX-K2 can receive and transmit.

Depending on the particular device that you are using, some messages may not be available. Refer to the owner's manual of the device for details.

CHANNEL MESSAGES

Channel messages are the data related to the performance on the keyboard for the specific channel.

■ Note On/Note Off (Key On/Key Off)

Messages which are generated when the keyboard is played.

Transmission note range = C-2 (0) - G8 (127), C3 = 60

Velocity range = 1 - 127 (only Note On velocity is transmitted)

Note On: Generated when a key is pressed.

Note Off: Generated when a key is released.

Each message includes a specific note number which corresponds to the key which is pressed, plus a velocity value based on how hard the key is struck.

■ Bank Select

● Bank Select MSB (Control #000)

● Bank Select LSB (Control #032)

Messages (MSB/LSB) which set the voice bank of a tone generator.

When used on an XG-compatible tone generator set to XG operation, normal or drum voice bank is selected by the MSB value, and the particular voice bank is selected by the LSB value. With Yamaha MU-series instruments,

bank select will not function when a GM System On message is received.

■ Control Change

Control Change messages let you control volume, panning, modulation, portamento time, brightness and various other controller parameters, through specific Control Change numbers which correspond to each of the various parameters.

● Modulation (Control #001)

Messages which control vibrato depth using the Modulation Wheel.

Setting the value to 127 produces maximum vibrato and 0 results in vibrato off.

● Portamento Time (Control #005)

Messages which control the duration of portamento, or a continuous pitch glide between successively played notes.

Setting the value to 127 produces maximum portamento time and 0 results in minimum portamento time.

Portamento is turned on/off by Control #065.

● Data Entry MSB (Control #006)

● Data Entry LSB (Control #038)

Messages which set the value for the parameter specified by RPN or NRPN MSB/LSB. Parameter value is determined by combining MSB and LSB.

● Main Volume (Control #007)

Messages which control the volume.

Setting the value to 127 produces maximum volume and 0 results in volume off.

● Pan (Control #010)

Messages which control the stereo panning position of each voice (for stereo output).

Setting the value to 127 positions the sound to the far right and 0 positions the sound to the far left.

● Expression (Control #011)

Messages which control intonation expression of each voice during performance.

Setting the value to 127 produces maximum volume and 0 results in volume off.

● Sustain Switch (Control #064)

Messages which control sustain on/off.

Setting the value between 64 - 127 turns the sustain on, between 0 - 63 turns the sustain off. On the CBX-K2, a connected footswitch can be assigned to control sustain when "SUS" is set.

About MIDI

● Portamento Switch (Control #065)

Messages which control portamento on/off.

Setting the value between 64 -127 turns the portamento on, between 0 - 63 turns the portamento off.

● Sostenuto Switch (Control #066)

Messages which control sostenuto on/off.

Setting the value between 64 - 127 turns sostenuto on, between 0 - 63 turns sostenuto off.

When notes are held before and during the time sostenuto is turned on, those notes (and only those notes) will be sustained until sostenuto is turned off.

● Soft Pedal Switch (Control #067)

Messages which control soft pedal on/off.

Setting the value between 64 - 127 turns soft pedal on, between 0 - 63 turns soft pedal off.

When soft pedal is on, the sound becomes softer and lower in volume.

● Harmonic Content (Control #071)

Messages which adjust the VCF resonance set for each voice.

Higher values will result in a more characteristic, resonant sound. Depending on the voice, the effective range may be narrower than the range available for adjustment.

● Release Time (Control #072)

Messages which directly adjust the AEG release time set for each voice.

● Attack Time (Control #073)

Messages which directly adjust the AEG attack time set for each voice.

● Brightness (Control #074)

Messages which directly adjust the VCF cutoff frequency set for each voice.

Lower values will result in a softer sound. Depending on the voice, the effective range may be narrower than the range available for adjustment.

● Effect1 Depth (Reverb) (Control #091)

Messages which adjust the send level for the Reverb effect.

● Effect3 Depth (Variation Chorus) (Control #093)

Messages which adjust the dry/wet balance for the Chorus Variation Effect.

● Effect4 Depth (Variation Depth) (Control #094)

Messages which adjust the send level for the Variation depth.

● Data Increment (Control #096)

● Decrement (Control #097) for RPN

Messages which increase or decrease the value of Pitch Bend Sensitivity, Fine Tune, or Coarse Tune.

You must assign one of those parameters using the RPN in the external device in advance.

● RPN (Registered Parameter Number) LSB (Control #100)

● RPN (Registered Parameter Number) MSB (Control #101)

Messages which offset, or add or subtract values from the Pitch Bend Sensitivity, Fine Tune, or Coarse Tune parameters.

First send the RPN MSB and RPN LSB to specify the parameter which is to be controlled. Then use Data Increment/Decrement to set the value of the specified parameter.

Note that once the RPN has been set for a channel, subsequent data entry will be recognized as the same RPN's value change. Therefore after you use the RPN, you should set a Null (7FH, 7FH) value to avoid an unexpected result.

Messages which can be transmitted are as follows:

RPN MSB	RPN LSB	Parameter
00	00	Pitch Bend Sensitivity
00	01	Fine Tune
00	02	Coarse Tune
7F	7F	Null

■ Channel Mode Messages

2nd Byte	3rd Byte	Message
120	0	All Sounds Off
121	0	Reset All Controllers
123	0	All Notes Off
126	0-16	Mono
127	0	Poly

● All Sounds Off (Control #120)

Clears all sounds currently sounding on the specified channel. However, the status of channel messages such as Note On and Hold On is maintained.

● Reset All Controllers (Control #121)

The values of the following controllers will be reset to the defaults: Pitch Bend, Channel Pressure, Sustain Switch, Modulation, Expression, Portamento, RPN*, NRPN*, Volume, Pan.

* Number not specified; internal data will not change.

● All Notes Off (Control #123)

Clears all notes currently on for the specified channel.

However, if Sustain Switch or Sostenuto Switch is on, notes will continue sounding until these are turned off.

This message cannot be sent by any CBX-K2 operation; however, when a MIDI error occurs, this message is sent automatically.

● Mono (Control #126)

Performs the same function as when an All Sounds Off message is received, and if the 3rd byte (mono number) is in the range of 0 - 16, sets the corresponding channel to Mono Mode (Mode 4 : m = 1).

● Poly (Control #127)

Performs the same function as when an All Sounds Off message is received, and sets the corresponding channel to Poly Mode (Mode 3).

■ Program Change

Messages which select voices.

■ Channel Aftertouch

The CBX-K2 keyboard does not have aftertouch sensitivity and thus cannot send aftertouch messages by keyboard pressure. However, Channel Aftertouch data can be sent by the Assignable Wheel or Slider. Channel Aftertouch affects the sound of all notes when it is applied.

■ Polyphonic Aftertouch

The CBX-K2 keyboard does not have aftertouch sensitivity and thus cannot send aftertouch messages by keyboard pressure. However, Polyphonic Aftertouch data can be sent by the Assignable Wheel or Slider. Polyphonic Aftertouch affects the sound of only the top

note (when several notes are played together) when it is applied.

■ Pitch Bend

Pitch Bend messages are continuous controller messages that allow the pitch of designated notes to be raised or lowered by a specified amount over a specified duration.

SYSTEM MESSAGES

System messages are the data related to the overall system of the device.

■ System Exclusive Messages

System Exclusive messages let you use the CBX-K2 to control various functions on connected devices, including master volume and master tuning, effect type and various other parameters.

● Master Volume

This message controls the volume over all MIDI channels.

F0 7F 7F 04 01 ll mm F7 (Hexadecimal)

* mm(MSB) = appropriate volume value, ll(LSB) = ignored

■ Active Sensing

Once FE (Active Sensing) has been received, if no MIDI data is subsequently received for longer than an interval of approximately 300msec, the CBX-K2 will register an Active Sensing error.

Refer to the following MIDI Data Format for more information about the various messages.

● Decimal-Hexadecimal Conversion Chart

Dec	Hex	Dec	Hex	Dec	Hex	Dec	Hex	Dec	Hex	Dec	Hex	Dec	Hex	Dec	Hex
0	00	16	10	32	20	48	30	64	40	80	50	96	60	112	70
1	01	17	11	33	21	49	31	65	41	81	51	97	61	113	71
2	02	18	12	34	22	50	32	66	42	82	52	98	62	114	72
3	03	19	13	35	23	51	33	67	43	83	53	99	63	115	73
4	04	20	14	36	24	52	34	68	44	84	54	100	64	116	74
5	05	21	15	37	25	53	35	69	45	85	55	101	65	117	75
6	06	22	16	38	26	54	36	70	46	86	56	102	66	118	76
7	07	23	17	39	27	55	37	71	47	87	57	103	67	119	77
8	08	24	18	40	28	56	38	72	48	88	58	104	68	120	78
9	09	25	19	41	29	57	39	73	49	89	59	105	69	121	79
10	0A	26	1A	42	2A	58	3A	74	4A	90	5A	106	6A	122	7A
11	0B	27	1B	43	2B	59	3B	75	4B	91	5B	107	6B	123	7B
12	0C	28	1C	44	2C	60	3C	76	4C	92	5C	108	6C	124	7C
13	0D	29	1D	45	2D	61	3D	77	4D	93	5D	109	6D	125	7D
14	0E	30	1E	46	2E	62	3E	78	4E	94	5E	110	6E	126	7E
15	0F	31	1F	47	2F	63	3F	79	4F	95	5F	111	6F	127	7F

MIDI Data Format

MIDI Reception

● Merge-related Notes

When Merge is set to ON, MIDI messages received from an external device at MIDI IN can be merged with the data generated by the CBX-K2, and are transmitted as is from MIDI OUT. However, there are some exceptions, as listed below:

- * Active sensing messages <<FE>>, All Note Off messages (<<Bn 7B 00>>) <<F4>> and <<F5>> will not be merged.
- * When the CBX-K2 is set to send <<F8>> messages, <<F8>> messages from an external device will **not** be merged.
- * When the CBX-K2 is **not** set to send <<F8>> messages, <<F8>> messages from an external device **can** be merged.
- * When Merge is set to ON, and an <<FE>> message has not been received for over approximately 300 ms, an Active Sensing error occurs.
- * With the exception of System Exclusive data, messages not conforming to the legal byte format will not be merged. System Exclusive data that doesn't conform to the legal byte format can be merged.
- * If during transmission of System Exclusive messages, the messages are cut off or interrupted (for over approximately 400 ms), a MIDI error occurs.
- * When Merge is set to on, and RPN/NRPN messages are sent from both the CBX-K2 and an external device connected to MIDI IN, the resulting messages may be mixed and corrupted.
- * When Merge is turned off while a key is held, a stuck note results. This is because the CBX-K2 simply turns Merge off, without changing the Note On status.

During merging of System Exclusive data, all operations from the CBX-K2 are ignored, and <<FE>> and <<F8>> messages from the CBX-K2 will be stopped. This may cause some problems, as listed below:

- * Any operations executed from the CBX-K2, in the middle of a System Exclusive message (<<F0- F7>>) sent from an external device, are ignored.
- * CBX-K2 operations that start before or end after the System Exclusive message will be incomplete.

To avoid these problems:

- * Turn Merge off or disconnect the MIDI cable (if the Merge function is not needed).
- * Do not operate the CBX-K2 during reception of large System Exclusive messages, such as bulk dumps.
- * When receiving many short System Exclusive messages, operate the CBX-K2 slowly, or avoid operating it at all.

● Response of the CBX-K2 During MIDI Errors

When a MIDI reception error occurs (such as buffer full, Active Sensing, interruption of System Exclusive, etc.), the CBX-K2 responds as follows:

1. Merge is set to OFF.
2. Damper Off, All Note Off, All Sound Off messages are transmitted over all channels.
3. The OCTAVE SHIFT ▶ lamp flashes and the relevant error number appears in the LED display.

To set Merge to ON again, hold down SHIFT and press MERGE ON/OFF.

MIDI Transmission

1. Transmit Condition

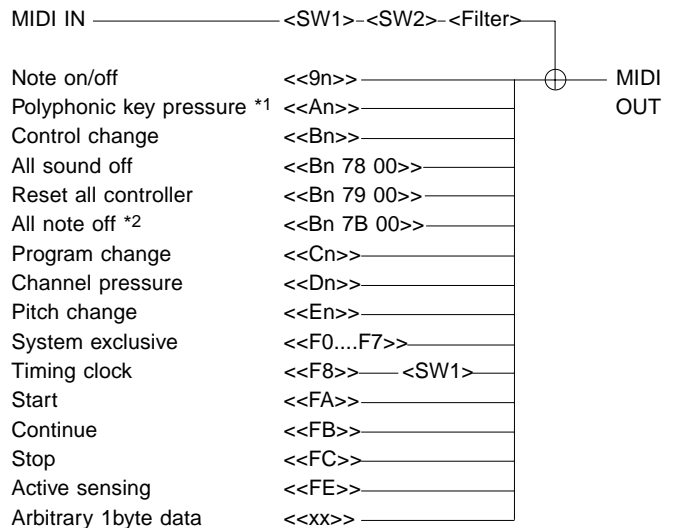

*1 This applies only to the highest note played.

*2 This is output only when a MIDI error (such as Active Sensing or buffer full) occurs.

<SW1> When the CBX-K2 is set to send <<F8>> messages, <<F8>> messages from the CBX-K2 will be output. When the CBX-K2 is not set to send <<F8>> messages, <<F8>> messages from the CBX-K2 will not be output, but <<F8>> messages from a connected external device will be merged.

<SW2> When Merge is set to ON, the incoming data is merged.

<Filter> This is Merge On/Off for each channel.

2. Overview

Transmitted data includes messages from the CBX-K2 itself and messages from an external device connected to MIDI IN. Besides conventional MIDI messages, single byte data can also be transmitted.

3. Transmitted Data

3.1 Channel Voice Messages

(1) Note on/off <<9n kk vv>>
 n=Channel 0-15
 kk=Note number 0-127
 vv=Velocity 0 : note off, 1-127 : note on

(2) Polyphonic key pressure <<An kk vv>>
 n=Channel 0-15
 kk=Note number 0-127
 vv=Pressure value 0-127

* When pressing several keys simultaneously, after touch of only the highest note number is output.

* Though the keyboard of the CBX-K2 itself has no after touch, after touch data can be transmitted from the Assignable Wheel or Slider when Channel pressure or Polyphonic key pressure is assigned to the controller.

(3) Control change <<Bn cc vv>>
 n=Channel 0-15
 cc=Control number 0-119
 vv=Control value

* When RPN or NRPN is assigned to the Assignable Wheel or Slider, the MSB, LSB and data entry values are transmitted in a group each time.

(4) Program change <<Cn pp>>
 n=Channel 0-15
 pp=Program number 0-127

(5) Channel pressure <<Dn vv>>
 n=Channel 0-15
 vv=Pressure value 0-127

* Though the keyboard of the CBX-K2 itself has no after touch, after touch data can be transmitted from the Assignable Wheel or Slider when Channel pressure is assigned to the controller.

(6) Pitch bend change <<En ll mm>>
 n=Channel 0-15
 ll=Pitch bend value LSB 0-127
 mm=Pitch bend value MSB 0-127

* MSB and LSB data (depending on Pitch Bend Wheel position):

	MSB	LSB
Maximum	0	0
Center	64	0
Minimum	127	126

* When MSB < 64, LSB = 0. When MSB > 64, LSB = (MSB - 64) x 2.

3.2 Channel Mode Messages

(1) All sound off <<Bn 78 00>>
 n=Channel 0-15

(2) Reset all controller <<Bn 79 00>>
 n=Channel 0-15

(3) All note off <<Bn 7B 00>>
 n=Channel 0-15

(4) Mono <<Bn 7E 00>>
 n=Channel 0-15

(5) Poly <<Bn 7F 00>>
 n=Channel 0-15

3.3 System Exclusive Messages

(1) GM system on <<F0 7E 7F 09 01 F7>>

(2) XG system on <<F0 43 1n 4C 00 00 7E 00 F7>>
 n=Device number

(3) Master volume <<F0 7F 7F 04 01 00 vv F7>>
 vv=Volume value 0-127

(4) Master balance <<F0 7F 7F 04 02 00 vv F7>>
 vv=Balance value 0-127

(5) Master tuning <<F0 43 1s 27 30 00 00 pm pl 00 F7>>
 s=Device number 0-15
 pm=Tuning value MSB (higher 4 bits of 1-byte data)
 pl=Tuning value LSB (lower 4 bits of 1-byte data)

(6) TG300B reset <<F0 41 10 42 12 40 00 7F 00 41 F7>>

(7) MU100R Voice Map <<F0 43 1s 49 00 00 12 vv F7>>
 s=Device number 0-15
 vv=0 : MU basic
 vv=1 : MU100R Native

3.4 System Common Messages

(1) Song select <<F3 vv>>
 vv=Song number 0-127

(2) Song position pointer <<F2 ll mm>>
 ll=Song position pointer LSB 0-127
 mm=Song position pointer MSB 0-127

3.5 System Real Time Messages

(1) Timing clock <<F8>>
 (2) Start <<FA>>
 (3) Continue <<FB>>
 (4) Stop <<FC>>
 (5) Active sensing <<FE>> Transmission should not be paused for longer than 250 ms.

3.6 Single-byte Data Transmission

(1) Single-byte data <<xx>>xx=0-255
 Separate from conventional MIDI message transmission, single byte messages can also be transmitted.

3.7 Others

* Running Status bytes are not used. However, incoming Running Status messages are added and transmitted.
 * If the incoming Note Off messages include <<8n>> status, the <<8n>> status is merged and output as is. (The CBX-K2 transmits Note Off messages as <<9n>> status with a velocity of 0.)

Function ...	Transmitted	Recognized	Remarks
Basic Default	: 1	: x	
Channel Changed	: 1 - 16	: x	
Mode Default	: -	: x	
Mode Messages	: x	: x	
Mode Altered	: *****	: x	
Note Number : True voice	: 0 - 127 : *****	: x : x	
Velocity Note ON	: o 9nH,v=1-127	: x	
Velocity Note OFF	: x 9nH,v=0	: x	
After Key's	: o *1, *2	: x	
Touch Ch's	: o *1	: x	
Pitch Bend	: o	: x	
Control Change	: 0-119 : o : 120 : o : 121 : o	: x : x : x	: Assignable : All Sound Off : Reset All Cntrls
Prog Change : True #	: o 0 - 127 : *****	: x : x	
System Exclusive	: o	: x	
common : Song Pos.	: o	: x	
common : Song Sel.	: o	: x	
common : Tune	: x	: x	
System :Clock	: o	: x	
Real Time :Commands	: o	: x	
Aux :Local ON/OFF	: x	: x	
Aux :All Notes OFF	: x	: x	
Mes- :Active Sense	: o	: o	
sages:Reset	: x	: x	
Notes: *1	though the keyboard itself has no after touch, after touch data can be transmitted from the ASSIGNABLE WHEEL and ASSIGNABLE SLIDER when after touch is assigned to the controllers.		
Notes: *2	this applies only to the highest note played.		
Mode 1	: OMNI ON, POLY	Mode 2 : OMNI ON, MONO	o : Yes
Mode 3	: OMNI OFF, POLY	Mode 4 : OMNI OFF, MONO	x : No

Troubleshooting

Even though the CBX-K2 is easy to use, it may occasionally not function as you expect it to. If that happens, check the possible problems and solutions below before assuming that the instrument is faulty.

● (Problem)

— (Possible Cause and Solution)

● No sound from the connected device.

- The cables may have been connected incorrectly.
- Controller data, such as Volume, Expression and Master Volume, may have been set to values too low to produce sound.
- The Fixed Velocity setting may be too low.

● When the power is turned off and on again, the settings you made have been cancelled.

- This is normal. The CBX-K2 has no internal memory backup.

● Sound is cut off.

- When incoming active sensing messages exceed that allowed by the MIDI standard, the sound will automatically be cut off.

● A certain function does not respond or work properly.

- The connected MIDI device may not support the relevant function on the CBX-K2.

● Specific functions/messages cannot be executed or sent properly.

- While holding down **SHIFT** in the middle of an operation, you may have inadvertently released **SHIFT**. Make sure to hold down **SHIFT** for the duration of the operation.

● The connected device does not respond or synchronize to MIDI clock messages, or MIDI clock messages are not sent.

- Make sure that the Tempo setting on the CBX-K2 is set to a value other than *OFF*. Also make sure that the connected device is set properly for receiving MIDI clock messages. If another device is connected to the MIDI IN of the CBX-K2 and that device is sending the MIDI clock messages, Merge must be set to ON.

● The Tempo cannot be set.

- The Tempo setting is inactive when Tempo is assigned to the Assignable Wheel or Slider.

● With Merge set to ON, tempo change messages sent from an external device have no effect.

- If an external device is connected to the MIDI IN of the CBX-K2, and the CBX-K2 is sending its own MIDI clock messages, the MIDI clock messages of the external device will not be sent via MIDI OUT. To have the external device's clock messages sent, set Tempo on the CBX-K2 to 0.

● Sending a bank select message also sends a program change message.

- This is normal. The CBX-K2 automatically sends the currently set program change number together with a bank select message.

● The RPN or NRPN controller number assigned to the Assignable Wheel doesn't function properly.

● The RPN or NRPN direct data send function doesn't

work properly.

- Please refer to the Merge-related Notes, page 34.

● Octave Shift function has no effect.

- Octave Shift cannot be changed while a key is being held down.

● The error message “E 2” appears in the LED display and the **OCTAVE SHIFT** lamp flashes, indicating a “MIDI buffer full” error.

- A MIDI “loop” may have been set up. To remedy this, set MIDI Merge to OFF. (Pages 26 and 28.)
- Too much MIDI data (exceeding the receive capability of the CBX-K2) may have been received at MIDI IN.

● An “E 1” message appears in the LED display.

- The battery power is too low for proper operation. Replace all batteries.

● The keyboard is not touch sensitive.

- Make sure that Fixed Velocity is set to *OFF*.
- When the Assignable Wheel or Slider is assigned to Velocity (157), Touch Sensitivity does not function.

● The Fixed Velocity setting has no effect.

- The Fixed Velocity setting is inactive when Velocity is assigned to the Assignable Wheel or Slider.

● Even when Touch Sensitivity is active, the effective velocity range is narrower than expected.

- Please refer to Footnote #5 on page 28 for details on velocity range.

● The All Sound Off function has no effect.

- All Sound Off in the Group A functions only applies to the currently selected MIDI channel.

● The right-most five keys of the keyboard do not sound at the expected pitch.

- When set to the highest octave range, the right-most five keys are set one octave down.

● Some of the keys do not respond to after touch pressure when playing several notes simultaneously.

- Polyphonic Key Pressure (After Touch) applies only to the highest note played.

● Incoming data is not merged.

- Make sure that Merge is set to ON. Make sure also that the Merge on/off function in Group B is set to ON for the relevant MIDI channel.

● Some messages cannot be merged.

- Please refer to the Merge-related Notes, page 34.

● Merge is inadvertently set to OFF.

- When there is a MIDI error, Merge is automatically turned off. Please also refer to the Merge-related Notes, page 34.

● The tone generator continues to sound after a key is released.

- This may be caused by a MIDI error and may happen depending on the Merge setting. Please refer to the Merge-related notes, page 34.

● When turning Merge off, the connected tone generator continues to sound.

- Execute the All Sound Off function (in the Group B functions; pages 28 – 29).
- Please refer to the Merge-related Notes, page 34.

Error Messages

The following messages may appear in the LED display during operation, indicating problems or incorrect operation.

E 1	Batteries are low The battery power is too low for operation. Replace all batteries with a complete set of six new batteries of the same type.
E 2	MIDI buffer full Too much MIDI data has been received. Eliminate unnecessary MIDI data.
E 3	Active Sensing error This error occurs when a MIDI cable is connected to the MIDI IN terminal of the CBX-K2 and Active Sensing messages <<FE>> have not been received for a certain amount of time or the MIDI cable has been accidentally disconnected.
E 4	SysEx data error The received System Exclusive message is incorrect. Confirm the contents of the transmitted data (such as necessary MSB, LSB, etc.) and attempt the operation again.
E 5	MIDI framing error An error occurred during the reception of MIDI data.

NOTE — About messages E2 – E5

■ Error messages E2 – E5 occur during the reception of MIDI data when Merge is turned on. Exit from the error message by pressing **SHIFT** or any other panel button.

■ When any of these error messages occurs, Merge is automatically turned off, and the following messages are transmitted over all MIDI channels 1 – 16: Hold 1 (damper) OFF, All Note OFF, and All Sound OFF.

Specifications

● Keyboard

49 key keyboard (C1 – C5), velocity responsive

● Functions

Basic: Octave Shift (-3 – +4 octaves), Pitch Bend Wheel, Assignable Wheel, Assignable Slider, MIDI Merge (MIDI IN)

MIDI Data: Sequencer control, MIDI clock, Bank Select, Program Change, GM System On, XG System On, TG300B Reset, Control Change, All Sound Off, Reset All Controllers, and others

Assignable Parameters: Transpose (± 12 semitones), MIDI Transmit Channel, Fixed Velocity, Touch Sensitivity, Device Number, Merge On/Off (each channel), Pitch Bend Wheel density, Assignable Slider density, Assignable Wheel density, Footswitch function

● Panel Controls and Indicators

SHIFT button, OCTAVE SHIFT ◀/▶ buttons and lamps, Pitch Bend Wheel, Assignable Wheel, Assignable Slider, POWER switch

● Display

8 segment, 3 digit

● Input/Output Terminals

MIDI IN, MIDI OUT, DC IN, FOOTSWITCH

● Power Supply

Yamaha PA-1D AC Power Adaptor, or six “AA” size, SUM-3, R-6 or equivalent batteries.

● Dimensions (W x D x H)

817 x 202 x 85 mm (32-1/8" x 8" x 3-1/3")

● Weight (without batteries)

2.6 kg (5 lbs., 12 oz.)

* Specifications and appearance subject to change without notice.

About RPN and NRPN

Registered Parameter Numbers (RPN) are controllers that have been added to the MIDI specification and are common among various MIDI devices of different manufacturers. Unlike the Control Change numbers, these use messages composed of three bytes: MSB, LSB and Data Entry.

Non-Registered Parameter Numbers (NRPN) are controllers that have been created by one or more manufacturers, but have not been added to the MIDI specification.

Thus, NRPN functions may be found on some instruments and not others. The NRPN functions of the CBX-K2 support all XG-compatible devices. Unlike the Control Change numbers, these use messages composed of three bytes: MSB, LSB and Data Entry.

Other RPN or NRPN messages not provided on the panel can be transmitted using the RPN or NRPN functions in Group A and B.

Index

- A**
 - All Sound Off (all channels) 28
 - All Sound Off (current channel) 26
 - Assignable Slider 9, 18
 - Assignable Wheel 9, 18

- B**
 - Bank LSB (Display) 26
 - Bank LSB 17
 - Bank MSB (Display) 26
 - Bank MSB 17
 - Bank Select 17, 26
 - basic operations 21
 - batteries 12
 - Bottom (Time Signature) 28

- C**
 - Channel Merge 28
 - connections 15
 - Continue (Sequencer) 26
 - Controller (Slider Assign) 26
 - Controller (Wheel Assign) 26
 - Controller Direct Data Send
(controller number) 28
 - Controller Direct Data Send
(NRPN) 28
 - Controller Direct Data Send (RPN) 28
 - Controller Number List 30

- D**
 - Data Density (Pitch Bend) 28
 - Data Density (Slider) 28
 - Data Density (Wheel) 28
 - DC IN terminal 11
 - decimal 21,23
 - default settings 10
 - Device Number 28
 - Drum Number 23,26

- E**
 - Error Messages 38

- F**
 - Fixed Velocity 26
 - FOOT SWITCH jack 11
 - Footswitch Assign 28

- G**
 - GM On 26
 - Group A functions, selecting 21, 22
 - Group A 21, 22

- Group B functions, selecting 21, 24
- Group B 21, 24

- H**
 - hexadecimal 21,23

- L**
 - LED display 10

- M**
 - Measure (Sequencer) 28
 - Merge On/Off (all channels) 26
 - Merge On/Off (each channel) 28
 - Merge 26, 28, 34
 - MIDI Data Format 34
 - MIDI IN terminal 11
 - MIDI messages
 - Active Sensing 33
 - Bank Select 31
 - Channel Aftertouch 33
 - Channel Mode Message 32
 - Channel Message 31
 - Control Change 31
 - Note On/Note Off 31
 - Pitch Bend 33
 - Polyphonic Aftertouch 33
 - Program Change 33
 - System Exclusive 33
 - System Message 33
 - MIDI OUT terminal 11
 - MIDI Transmit Channel 26
 - MIDI, About 31
 - MSB 1ST/LSB 1ST 28
 - MSB/LSB Invert 28

- N**
 - NRPN, About 39
 - NRPN (Slider Assign) 26
 - NRPN (Wheel Assign) 26

- O**
 - octave range, changing 17
 - OCTAVE SHIFT ◀/▶ buttons 9
 - OCTAVE SHIFT ◀/▶ lamps 9

- P**
 - PB (Pitch Bend) Density 28
 - Pitch Bend Wheel 9, 18
 - Poly/Mono 28
 - power adaptor 12
 - power supply 12

- POWER switch 11
- Program Change (Display) 26
- Program Change 26

- R**
 - Reset All Controllers 28
 - RPN, About 39
 - RPN (Slider Assign) 26
 - RPN (Wheel Assign) 26

- S**
 - setup examples 13
 - SHIFT button 9
 - SHIFT-related functions 20
 - single-byte message, sending 25
 - Slider Assign 26
 - Specifications 39
 - Start (Sequencer) 26
 - Stop (Sequencer) 26

- T**
 - Tempo (Sequencer) 26
 - TG300B Reset 28
 - Time Signature 28
 - Top (Time Signature) 28
 - Touch Sensitivity 19, 28
 - Transpose 23, 26
 - Troubleshooting 37

- V**
 - values, entering 21
 - voice banks, changing 17
 - Voice Map 28
 - voices, selecting and playing 16

- W**
 - Wheel Assign 26

- X**
 - XG On 26



FCC INFORMATION (U.S.A.)

1. IMPORTANT NOTICE: DO NOT MODIFY THIS UNIT!

This product, when installed as indicated in the instructions contained in this manual, meets FCC requirements. Modifications not expressly approved by Yamaha may void your authority, granted by the FCC, to use the product.

2. IMPORTANT:

When connecting this product to accessories and/or another product use only high quality shielded cables. Cable/s supplied with this product MUST be used. Follow all installation instructions. Failure to follow instructions could void your FCC authorization to use this product in the USA.

3. NOTE:

This product has been tested and found to comply with the requirements listed in FCC Regulations, Part 15 for Class "B" digital devices. Compliance with these requirements provides a reasonable level of assurance that your use of this product in a residential environment will not result in harmful interference with other electronic devices. This equipment generates/uses radio frequencies and, if not installed and used according to the instructions found in the users manual, may cause interference harmful to the operation of other electronic devices. Compliance with FCC

regulations does not guarantee that interference will not occur in all installations. If this product is found to be the source of interference, which can be determined by turning the unit "OFF" and "ON", please try to eliminate the problem by using one of the following measures:

Relocate either this product or the device that is being affected by the interference.

Utilize power outlets that are on different branch (circuit breaker or fuse) circuits or install AC line filter/s.

In the case of radio or TV interference, relocate/reorient the antenna. If the antenna lead-in is 300 ohm ribbon lead, change the lead-in to co-axial type cable.

If these corrective measures do not produce satisfactory results, please contact the local retailer authorized to distribute this type of product. If you can not locate the appropriate retailer, please contact Yamaha Corporation of America, Electronic Service Division, 6600 Orangethorpe Ave, Buena Park, CA90620

The above statements apply ONLY to those products distributed by Yamaha Corporation of America or its subsidiaries.

* This applies only to products distributed by YAMAHA CORPORATION OF AMERICA.

Entsorgung leerer Batterien (nur innerhalb Deutschlands)

Leisten Sie einen Beitrag zum Umweltschutz. Verbrauchte Batterien oder Akkumulatoren dürfen nicht in den Hausmüll. Sie können bei einer Sammelstelle für Altbatterien bzw. Sondermüll abgegeben werden. Informieren Sie sich bei Ihrer Kommune.

For details of products, please contact your nearest Yamaha or the authorized distributor listed below.

Pour plus de détails sur les produits, veuillez-vous adresser à Yamaha ou au distributeur le plus proche de vous figurant dans la liste suivante.

Die Einzelheiten zu Produkten sind bei Ihrer unten aufgeführten Niederlassung und bei Yamaha Vertragshändlern in den jeweiligen Bestimmungsländern erhältlich.

Para detalles sobre productos, contacte su tienda Yamaha más cercana o el distribuidor autorizado que se lista debajo.

NORTH AMERICA

CANADA

Yamaha Canada Music Ltd.
135 Milner Avenue, Scarborough, Ontario,
M1S 3R1, Canada
Tel: 416-298-1311

U.S.A.

Yamaha Corporation of America
6600 Orangethorpe Ave., Buena Park, Calif. 90620,
U.S.A.
Tel: 714-522-9011

CENTRAL & SOUTH AMERICA

MEXICO

**Yamaha de Mexico S.A. De C.V.,
Departamento de ventas**
Javier Rojo Gomez No.1149, Col. Gpe Del
Moral, Deleg. Iztapalapa, 09300 Mexico, D.F.
Tel: 686-00-33

BRASIL

Yamaha Musical do Brasil LTDA.
Ave. Reboucas 2636, São Paulo, Brasil
Tel: 011-853-1377

ARGENTINA

Yamaha Music Argentina S.A.
Viamonte 1145 Piso2-B 1053,
Buenos Aires, Argentina
Tel: 1-371-7021

PANAMA AND OTHER LATIN AMERICAN COUNTRIES/ CARIBBEAN COUNTRIES

Yamaha de Panama S.A.
Torre Banco General, Piso 7, Urbanización Marbella,
Calle 47 y Aquilino de la Guardia,
Ciudad de Panamá, Panamá
Tel: 507-269-5311

EUROPE

THE UNITED KINGDOM

Yamaha-Kemble Music (U.K.) Ltd.
Sherbourne Drive, Tilbrook, Milton Keynes,
MK7 8BL, England
Tel: 01908-366700

IRELAND

Danfay Ltd.
61D, Sallynoggin Road, Dun Laoghaire, Co. Dublin
Tel: 01-2859177

GERMANY/SWITZERLAND

Yamaha Europa GmbH.
Siemensstraße 22-34, 25462 Rellingen,
F.R. of Germany
Tel: 04101-3030

AUSTRIA

Yamaha Music Austria
Schleiergasse 20, A-1100 Wien Austria
Tel: 01-60203900

THE NETHERLANDS

Yamaha Music Nederland
Kanaalweg 18G, 3526KL, Utrecht, The Netherlands
Tel: 030-2828411

BELGIUM

Yamaha Music Belgium
Keiberg Imperiastraat 8, 1930 Zaventem, Belgium
Tel: 02-7258220

FRANCE

**Yamaha Musique France,
Division Professionnelle**
BP 70-77312 Marne-la-Vallée Cedex 2, France
Tel: 01-64-61-4000

ITALY

**Yamaha Musica Italia S.P.A.,
Combo Division**
Viale Italia 88, 20020 Lainate (Milano), Italy
Tel: 02-935-771

SPAIN

Yamaha-Hazen Electronica Musical, S.A.
Jorge Juan 30, 28001, Madrid, Spain
Tel: 91-577-7270

PORTUGAL

Valentim de Carvalho CI SA
Estrada de Porto Salvo, Paço de Arcos 2780 Oeiras,
Portugal
Tel: 01-443-3398/4030/1823

GREECE

Philippe Nakas S.A.
Navarinou Street 13, P.Code 10680, Athens, Greece
Tel: 01-364-7111

SWEDEN

Yamaha Scandinavia AB
J. A. Wettergrens Gata 1
Box 30053
S-400 43 Göteborg, Sweden
Tel: 031 89 34 00

DENMARK

YS Copenhagen Liaison Office
Generatorvej 8B
DK-2730 Herlev, Denmark
Tel: 44 92 49 00

FINLAND

Warner Music Finland OY/Fazer Music
Aleksanterinkatu 11, P.O. Box 260
SF-00101 Helsinki, Finland
Tel: 0435 011

NORWAY

Norsk filial av Yamaha Scandinavia AB
Grini Næringspark 1
N-1345 Østerås, Norway
Tel: 67 16 77 70

ICELAND

Skifan HF
Skeifan 17 P.O. Box 8120
IS-128 Reykjavik, Iceland
Tel: 525 5000

OTHER EUROPEAN COUNTRIES

Yamaha Europa GmbH.
Siemensstraße 22-34, 25462 Rellingen, F.R. of
Germany
Tel: 04101-3030

AFRICA

**Yamaha Corporation,
International Marketing Division**
Nakazawa-cho 10-1, Hamamatsu, Japan 430
Tel: 053-460-2312

MIDDLE EAST

TURKEY/CYPRUS

Yamaha Europa GmbH.
Siemensstraße 22-34, 25462 Rellingen,
F.R. of Germany
Tel: 04101-3030

OTHER COUNTRIES

**Yamaha Corporation,
International Marketing Division**
Nakazawa-cho 10-1, Hamamatsu, Japan 430
Tel: 053-460-2312

ASIA

HONG KONG

Tom Lee Music Co., Ltd.
11/F., Silvercord Tower 1, 30 Canton Road,
Tsimshatsui, Kowloon, Hong Kong
Tel: 730-1098

INDONESIA

**PT. Yamaha Music Indonesia (Distributor)
PT. Nusantik**
Gedung Yamaha Music Center, Jalan Jend. Gatot
Subroto Kav. 4, Jakarta 12930, Indonesia
Tel: 21-520-2577

KOREA

Cosmos Corporation
#131-31, Neung-Dong, Sungdong-Ku, Seoul
Korea
Tel: 02-466-0021~5

MALAYSIA

Yamaha Music Malaysia, Sdn., Bhd.
16-28, Jalan SS 2/72, Petaling Jaya, Selangor,
Malaysia
Tel: 3-717-8977

PHILIPPINES

Yupangco Music Corporation
339 Gil J. Puyat Avenue, P.O. Box 885 MCPO,
Makati, Metro Manila, Philippines
Tel: 819-7551

SINGAPORE

Yamaha Music Asia Pte., Ltd.
Blk 202 Hougang, Street 21 #02-01,
Singapore 530202
Tel: 382-1922

TAIWAN

Yamaha KHS Music Co., Ltd.
10F, 150, Tun-Hwa Northroad,
Taipei, Taiwan, R.O.C.
Tel: 02-717-3812

THAILAND

Siam Music Yamaha Co., Ltd.
121/60-61 RS Tower 17th Floor,
Ratchadaphisek RD., Dindaeng,
Bangkok 10320, Thailand
Tel: 02-641-2951

THE PEOPLE'S REPUBLIC OF CHINA AND OTHER ASIAN COUNTRIES

**Yamaha Corporation,
International Marketing Division**
Nakazawa-cho 10-1, Hamamatsu, Japan 430
Tel: 053-460-2317

OCEANIA

AUSTRALIA

Yamaha Music Australia Pty. Ltd.
17-33 Market Street, South Melbourne, Vic. 3205,
Australia
Tel: 3-699-2388

NEW ZEALAND

Music Houses of N.Z. Ltd.
146/148 Captain Springs Road, Te Papapa,
Auckland, New Zealand
Tel: 9-634-0099

COUNTRIES AND TRUST TERRITORIES IN PACIFIC OCEAN

**Yamaha Corporation,
International Marketing Division**
Nakazawa-cho 10-1, Hamamatsu, Japan 430
Tel: 053-460-2317

YAMAHA
YAMAHA CORPORATION