

*Subwoofer*

# NS-SW100/NS-SW050

---



## CAUTION: Read this before operating your unit

Please read the following operating precautions before use. Yamaha will not be held responsible for any damage and/or injury caused by not following the cautions below.

- To assure the finest performance, please read this manual carefully. Keep it in a safe place for future reference.
- Install this unit in a cool, dry, clean place - away from windows, heat sources, sources of excessive vibration, dust, moisture and cold. Avoid sources of humming (transformers, motors). To prevent fire or electrical shock, do not expose this unit to rain or water.
- The voltage to be used must be the same as that specified on the rear panel. Using this unit with a higher voltage than specified is dangerous and may cause a fire and/or electric shock.
- Do not use force on switches, controls or connection wires. When moving the unit, first disconnect the power plug and the wires connected to other equipment. Never pull the wires themselves.
- When not planning to use this unit for a long period (i.e., vacation, etc.), disconnect the AC power plug from the wall outlet.
- To prevent lightning damage, disconnect the AC power plug when there is an electric storm.
- Since this unit has a built-in power amplifier, heat will radiate from the rear panel. Place the unit apart from the walls, allowing at least 20 cm of space above, behind and on both sides of the unit to prevent fire or damage. Furthermore, do not position with the rear panel facing down on the floor or other surfaces.
- Do not cover the rear panel of this unit with a newspaper, a tablecloth, a curtain, etc., in order not to obstruct heat radiation. If the temperature inside the unit rises, it may cause fire, damage to the unit and/or personal injury.
- Do not place the following objects on this unit:
  - Glass, china, small metallic, etc.  
If glass, etc., falls as a result of vibrations and breaks, it may cause bodily injury.
  - A burning candle etc.  
If the candle falls as a result of vibration, it may cause fire and bodily injury.
  - A vessel containing water  
If the vessel falls as a result of vibration and water spills, it may cause damage to the speaker, and/or you may get an electric shock.
- Do not place this unit where foreign material, such as dripping water. It might cause fire, damage to this unit, and/or personal injury.
- Never put a hand or a foreign object into the YST port located on the right side of this unit. When moving this unit, do not hold the port, as it might cause personal injury and/or damage to this unit.
- Never place a fragile object near the YST port of this unit. If the object falls or drops as a result of the air pressure, it may cause damage to the unit and/or personal injury.
- Never open the cabinet. It might cause an electric shock, since this unit uses a high voltage. It might also cause personal injury and/or damage to this unit. If something drops into the set, contact your dealer.
- When using a humidifier, be sure to avoid condensation inside this unit by allowing enough space around this unit or avoiding excess humidification. Condensation might cause fire, damage to this unit, and/or electric shock.
- Super-bass frequencies reproduced by this unit may cause a turntable to generate a howling sound. In such a case, move this unit away from the turntable.
- This unit may be damaged if certain sounds are continuously output at high volume level. For example, if 20 Hz - 50 Hz sine waves from a test disc, bass sounds from electronic instruments, etc., are continuously output, or when the stylus of a turntable touches the surface of a disc, reduce the volume level to prevent this unit from being damaged.
- If you hear distortion (i.e., unnatural, intermittent “rapping” or “hammering” sounds) coming from this unit, reduce the volume level. Extremely loud playing of a movie soundtrack’s low frequency, bass-heavy sounds or similarly loud popular music passages can damage this speaker system.
- Vibration generated by super-bass frequencies may distort images on a TV. In such a case, move this unit away from the TV set.
- Do not attempt to clean this unit with chemical solvents as this might damage the finish. Use a clean, dry cloth.
- Be sure to read the “TROUBLESHOOTING” section regarding common operating errors before concluding that the unit is faulty.
- Install this unit near the wall outlet and where the AC power plug can be reached easily.
- **Secure placement or installation is the owner’s responsibility. Yamaha shall not be liable for any accident caused by improper placement or installation of speakers.**

WARNING  
TO REDUCE THE RISK OF FIRE OR ELECTRIC SHOCK, DO NOT EXPOSE THIS APPLIANCE TO RAIN OR MOISTURE.

This unit is not disconnected from the AC power source as long as it is connected to the wall outlet, even if this unit itself is turned off. In this state, this unit is designed to consume a very small quantity of power.

#### For U.K. customers

If the socket outlets in the home are not suitable for the plug supplied with this appliance, it should be cut off and an appropriate 3 pin plug fitted. For details, refer to the instructions described below.

**Note:** The plug severed from the mains lead must be destroyed, as a plug with bared flexible cord is hazardous if engaged in a live socket outlet.

#### SPECIAL INSTRUCTIONS FOR U.K. MODEL

##### **IMPORTANT:**

THE WIRES IN MAINS LEAD ARE COLOURED IN ACCORDANCE WITH THE FOLLOWING CODE:

Blue: NEUTRAL

Brown: LIVE

As the colours of the wires in the mains lead of this apparatus may not correspond with the coloured markings identifying the terminals in your plug, proceed as follows: The wire which is coloured BLUE must be connected to the terminal which is marked with the letter N or coloured BLACK. The wire which is coloured BROWN must be connected to the terminal which is marked with the letter L or coloured RED. Make sure that neither wire is connected to the earth terminal of a three pin plug.

This unit's speakers use magnets. Do not place items that are sensitive to magnetism, such as CRT-type TVs, clocks, credit cards, floppy disks, etc., on or beside this unit.

#### Information for users on collection and disposal of old equipment:



This symbol on the products, packaging, and/or accompanying documents means that used electrical and electronic products should not be mixed with general household waste.

For proper treatment, recovery and recycling of old products, please take them to applicable collection points, in accordance with your national legislation.

By disposing of these products correctly, you will help to save valuable resources and prevent any potential negative effects on human health and the environment which could otherwise arise from inappropriate waste handling.

For more information about collection and recycling of old products, please contact your local municipality, your waste disposal service or the point of sale where you purchased the items.

#### **For business users in the European Union:**

If you wish to discard electrical and electronic equipment, please contact your dealer or supplier for further information.

#### **Information on Disposal in other Countries outside the European Union:**

This symbol is only valid in the European Union. If you wish to discard these items, please contact your local authorities or dealer and ask for the correct method of disposal.

#### **Taking care of the subwoofer**

- When you wipe this unit, do not use chemical solvents (e.g., alcohol or thinners, etc.): this might damage the finish. Use a clean, dry cloth. For difficult soils, dampen a soft cloth in water, wring it out, and then wipe with the cloth.
- (For polish-finished model) Bumping the surface of the instrument with metal, porcelain, or other hard objects can cause the finish to crack or peel. Use caution.

# CONTENTS

FEATURES .....	1
CONTROLS AND THEIR FUNCTIONS.....	1
PLACEMENT.....	2
CONNECTIONS .....	3
Connecting to such as subwoofer output terminal or line output (pin jack) terminals of the amplifier .....	3
Plug in the subwoofer to the AC outlet .....	3
ADJUSTING THE SUBWOOFER BEFORE USE .....	4
ADVANCED YAMAHA ACTIVE SERVO TECHNOLOGY II.....	5
TWISTED FLARE PORT .....	5
TROUBLESHOOTING.....	6
SPECIFICATIONS.....	7
Frequency characteristic .....	7

# FEATURES

- This subwoofer employs Advanced Yamaha Active Servo Technology II, which Yamaha has developed for the production of higher quality, super-bass sound. (Refer to page 5 for details on Advanced Yamaha Active Servo Technology II.) This super-bass sound adds a more realistic, theater-in-the-home effect to your audio system.
- Equipped with the smooth super-bass reproducing Twisted Flare Port.  
The flared, gently twisting shape diffuses the vortex of air generated around the edge of the port, creating a smooth flow of air. This reduces extraneous noise not present in the original input signal, and provides clear, accurate low frequency reproduction.

# CONTROLS AND THEIR FUNCTIONS

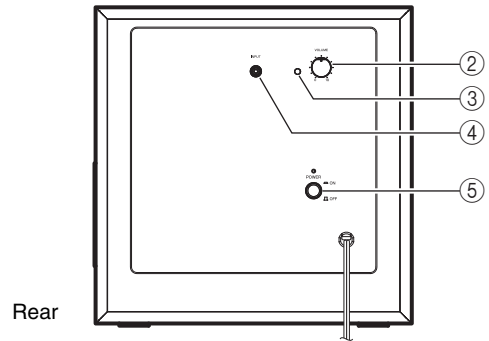
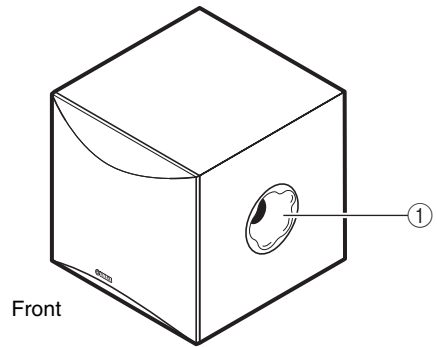

- ① **Twisted Flare Port**  
Outputs super-bass sound.
- ② **VOLUME control**  
Adjusts the volume level. Turn the control clockwise to increase the volume, and counterclockwise to decrease the volume.
- ③ **Power indicator**  
Lights up Green when the POWER switch is turned ON; turns off when the POWER switch is turned OFF.
- ④ **INPUT (FROM AMPLIFIER) terminal**  
Used to connect the subwoofer with the subwoofer terminal of the amplifier.  
(Refer to “CONNECTIONS” for details.)
- ⑤ **POWER switch**  
Press this switch to the ON position to turn on the power to the subwoofer. Press this switch again to set it to the OFF position to turn off the power of the subwoofer.

# PLACEMENT

Since the low-end frequencies of audio signals feature long wavelengths, they are almost non-directional to human ears. The super-bass range does not create a stereo image. Therefore, a single subwoofer may be enough to produce a high-quality super-bass sound.

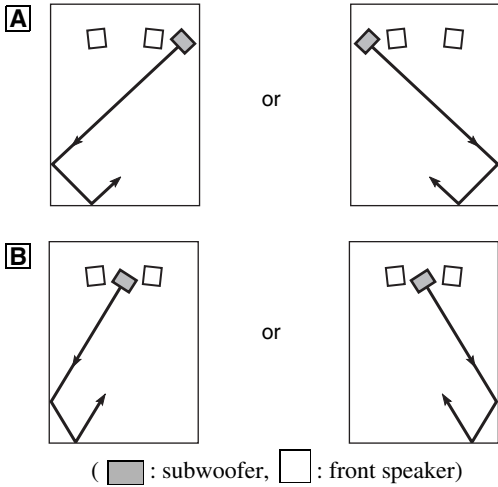

## Note

The placement shown in the figure on the right is also possible. However, if the subwoofer system is placed directly facing a wall, the bass effect may suffer due to phase cancellation caused by the interference between the direct and reflected sounds. To prevent this from happening, place the subwoofer system at an angle. (Figures **A** and **B**)

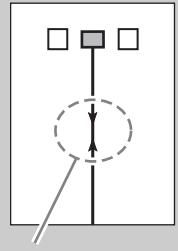

## Note

There may be a case that you cannot obtain enough super-bass sound from the subwoofer due to standing waves.

## Note

- Placing the subwoofer too close to a CRT-type TV may impair the picture color or cause a buzzing noise. In this case, place the subwoofer and TV at a separated position where these effects do not occur. This is not an issue with LCD and plasma TVs.
- If the speaker volume is very loud, furniture or window glass may resonate and the subwoofer itself may vibrate. In this case, lower the volume level. To limit resonance, use a thick curtain or similar cloth that tends to absorb sound vibrations effectively. Also, changing the subwoofer position may be helpful.

# CONNECTIONS

## Note

- Unplug the subwoofer and other audio/video components before making connections, and do not plug them in until all connections are completed.
- Connecting methods and terminal names on your component (such as an amplifier or receiver) may be different from those used in this book. Please refer to the owner's manual that came with your component.
- After connecting, make sure that cable is connected firmly.

## Connecting to such as subwoofer output terminal or line output (pin jack) terminals of the amplifier

Connect to the subwoofer output terminal of the amplifier (or AV receiver) using a commercially available audio pin cable.

If the amplifier (or AV receiver) has no subwoofer output terminal, connect to the line output (such as PRE OUT) terminal.

Amplifier (The rear panel of various amplifiers may differ in appearance.)

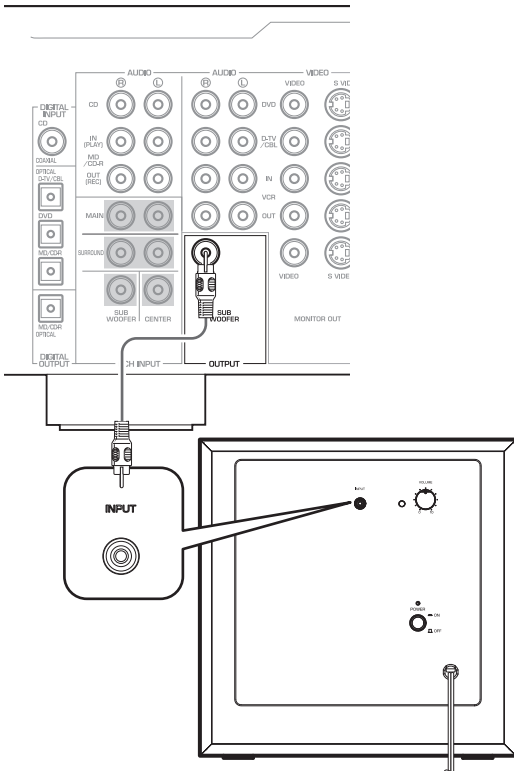

## Plug in the subwoofer to the AC outlet

After all connections are completed, plug the subwoofer and other audio/video components into AC outlets.

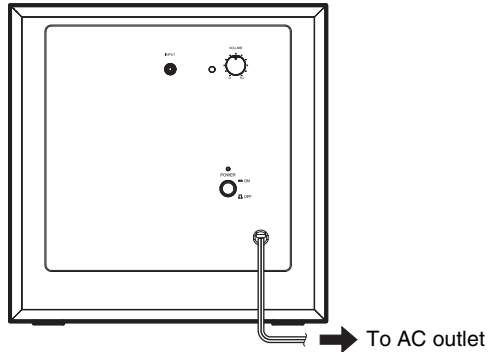

# ADJUSTING THE SUBWOOFER BEFORE USE

Before using the subwoofer, adjust the subwoofer to obtain the optimum volume balance between the subwoofer and the front speakers by following the procedure described below.



- 1 Set the **VOLUME** control to minimum (0).
- 2 Turn on the power of all the other components.
- 3 Make sure that the **POWER** switch is set to the ON position.  
\* The Power indicator lights up in green.
- 4 Play a source containing low-frequency components and adjust the amplifier's volume control to the desired listening level.
- 5 Increase the volume gradually to adjust the volume balance between the subwoofer and the front speakers.  
To enjoy natural bass sound, keep the subwoofer volume at a level where it is barely distinguishable from other speakers.

## Note

It is recommended to set the **VOLUME** control about in the middle position when using in a multi channel home theater system.

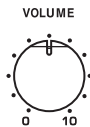

# ADVANCED YAMAHA ACTIVE SERVO TECHNOLOGY II

In 1988, Yamaha brought to the marketplace speaker systems utilizing YST (Yamaha Active Servo Technology) to give powerful, high quality bass reproduction. This technique uses a direct connection between the amplifier and speaker, allowing accurate signal transmission and precise speaker control.

As this technology uses speaker units controlled by the negative impedance drive of the amplifier and resonance generated between the speaker cabinet volume and port, it creates more resonant energy (the “air woofer” concept) than the standard bass reflex method. This allows for bass reproduction from much smaller cabinets than was previously possible.

Yamaha’s newly developed Advanced YST II adds many refinements to Yamaha Active Servo Technology, allowing better control of the forces driving the amplifier and speaker. From the amplifier’s point of view, the speaker impedance changes depending on the sound frequency. Yamaha developed a new circuit design combining negative-impedance and constant-current drives, which provides a more stable performance and clear bass reproduction, without any murkiness.

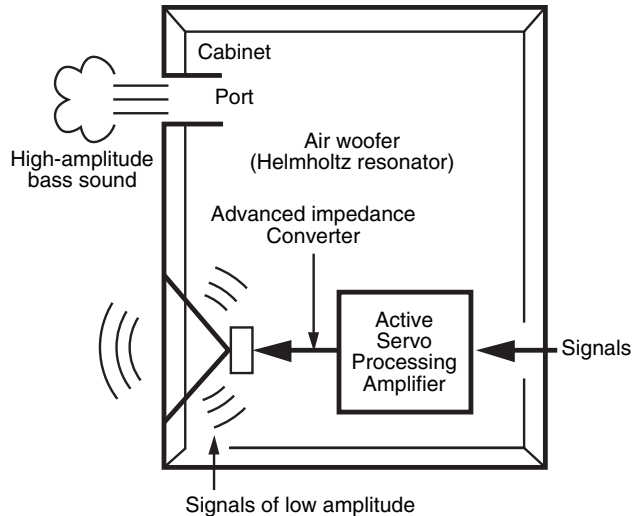

## TWISTED FLARE PORT

Today’s bass reflex speakers use a Helmholtz resonator to improve their bass reproduction.

However when reproducing bass that is in the frequency region of this Helmholtz resonator, air moves violently in and out through the port between the interior and exterior of the speaker, sometimes producing noise due to the turbulent air flow at the end of the port.

The port and the cabinet resonate at a frequency that is determined by their dimensions and shape. On the other hand, turbulence in the air flow at the end of the port contains a broad range of frequency components that are not present in the input signal. This noise occurs because the broad range of frequency components includes components that match the resonant frequencies of the port and cabinet, causing strong resonance.



The Twisted Flare Port developed by Yamaha changes the way in which the port widens toward its end, and also adds a “twist” to suppress airflow turbulence at each end of the port and thus prevent noise from occurring. This eliminates the “muddy sound” and “wind noise” that until now have been characteristic of bass reflex speakers, allowing bass to be reproduced clearly.

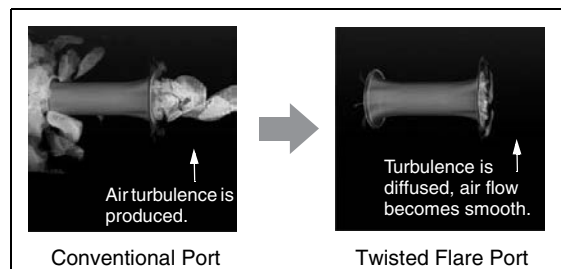

Air turbulence on both ends of the port creates noise



# TROUBLESHOOTING

Refer to the chart below if this unit does not function properly.

If the instructions given below do not help, or if the problem you are experiencing is not listed below, turn off the power to the unit, disconnect the power cord and contact an authorized Yamaha dealer or service center.

Problem	Cause	What to Do
<b>Power is not supplied even though the POWER switch is set to the ON position.</b>	The power plug is not securely connected.	Connect it securely.
<b>No sound.</b>	The volume is set to minimum.	Raise the volume up.
<b>No sound.</b>	Connections are faulty (or the connections are incomplete).	Connect them securely.
<b>The sound is interrupted.</b>	The volume is too loud.	Since the output is excessive, reduce the volume level.
<b>Sound level is too low.</b>	A source sound with little bass frequency content is being played.	Play a source sound with bass frequencies.
<b>Sound level is too low.</b>	It is influenced by standing waves.	Reposition the subwoofer or break up parallel surfaces by placing bookshelves, etc., along the walls.

# SPECIFICATIONS

## ■ NS-SW100

**Type**.....Advanced Yamaha Active Servo Technology II

**Driver** ..... 25 cm (10") cone woofer  
Non magnetic shielding type

**Amplifier Output (100 Hz, 5 ohms, 10% THD)** .... 50 W

**Dynamic Power** ..... 100 W, 5 Ω

**Frequency Response** ..... 25 Hz - 180 Hz

### Power Supply

Australia model..... AC 230-240 V, 50 Hz

U.K. model..... AC 230 V, 50 Hz

Asia model..... AC 220-240 V, 50/60 Hz

**Power Consumption** ..... 40 W

**Dimensions (W × H × D)** ... 351 mm × 352 mm × 408 mm  
(13-7/8" × 13-7/8" × 16-1/8")

**Weight** ..... 12 kg (26.5 lbs.)

## ■ NS-SW050

**Type**..... Advanced Yamaha Active Servo Technology II

**Driver** ..... 20 cm (8") cone woofer  
Non magnetic shielding type

**Amplifier Output (100 Hz, 5 ohms, 10% THD)** .... 50 W

**Dynamic Power** ..... 100 W, 5 Ω

**Frequency Response** ..... 28 Hz - 200 Hz

### Power Supply

Australia model..... AC 230-240 V, 50 Hz

U.K. model..... AC 230 V, 50 Hz

Asia model ..... AC 220-240 V, 50/60 Hz

**Power Consumption**..... 40 W

**Dimensions (W × H × D)**.... 291 mm × 292 mm × 341 mm  
(11-1/2" × 11-1/2" × 13-3/8")

**Weight** ..... 8.5 kg (18.7 lbs.)

\* The contents of this manual apply to the latest specifications as of the publishing date. To obtain the latest manual, access the Yamaha website then download the manual file.

## Frequency characteristic

This subwoofer's frequency characteristic

[NS-SW100]

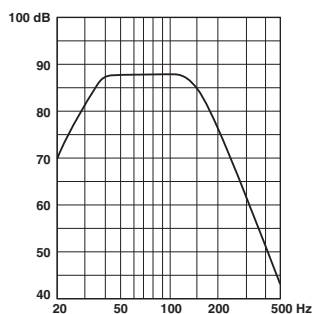

[NS-SW050]

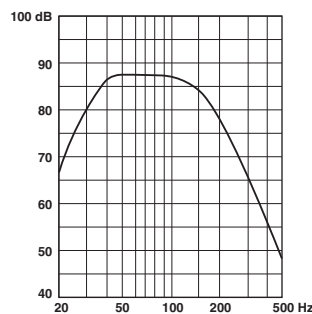

\* This diagram does not depict actual frequency response characteristics.

Yamaha Global Site  
<https://www.yamaha.com/>

Yamaha Downloads  
<https://download.yamaha.com/>

© 2016 Yamaha Corporation  
Published 01/2024 IPEI-B0

YAMAHA CORPORATION

10-1 Nakazawa-cho, Chuo-ku, Hamamatsu, 430-8650 Japan

VHH9620