



NS-P220

HOME CINEMA 5.1CH SPEAKER PACKAGE



OWNER'S MANUAL

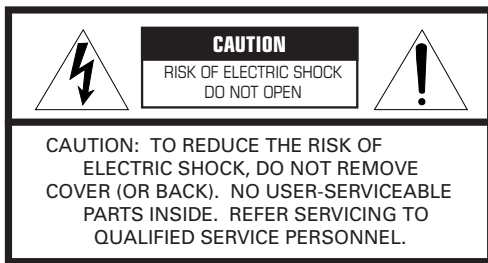

IMPORTANT
Please record the serial number of this system in the space below.

Model:

Serial No.:

The serial number is located on the rear of the main unit.
Retain this Owner's Manual in a safe place for future reference.

• Explanation of Graphical Symbols

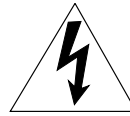

The lightning flash with arrowhead symbol, within an equilateral triangle, is intended to alert you to the presence of uninsulated "dangerous voltage" within the product's enclosure that may be of sufficient magnitude to constitute a risk of electric shock to persons.



The exclamation point within an equilateral triangle is intended to alert you to the presence of important operating and maintenance (servicing) instructions in the literature accompanying the appliance.

WARNING
TO REDUCE THE RISK OF FIRE OR ELECTRIC SHOCK, DO NOT EXPOSE THIS APPLIANCE TO RAIN OR MOISTURE.

SAFETY INSTRUCTIONS

- 1 Read Instructions – All the safety and operating instructions should be read before the unit is operated.
- 2 Retain Instructions – The safety and operating instructions should be retained for future reference.
- 3 Heed Warnings – All warnings on the unit and in the operating instructions should be adhered to.
- 4 Follow Instructions – All operating and other instructions should be followed.
- 5 Water and Moisture – The unit should not be used near water – for example, near a bathtub, washbowl, kitchen sink, laundry tub, in a wet basement, or near a swimming pool, etc.
- 6 Carts and Stands – The unit should be used only with a cart or stand that is recommended by the manufacturer.
- 6A A unit and cart combination should be moved with care. Quick stops, excessive force, and uneven surfaces may cause the unit and cart combination to overturn. 
- 7 Wall or Ceiling Mounting – The unit should be mounted to a wall or ceiling only as recommended by the manufacturer.
- 8 Ventilation – The unit should be situated so that its location or position does not interfere with its proper ventilation. For example, the unit should not be situated on a bed, sofa, rug, or similar surface, that may block the ventilation openings; or placed in a built-in installation, such as a bookcase or cabinet that may impede the flow of air through the ventilation openings.
- 9 Heat – The unit should be situated away from heat sources such as radiators, stoves, or other appliances that produce heat.
- 10 Power Sources – The unit should be connected to a power supply only of the type described in the operating instructions or as marked on the unit.
- 11 Power-Cord Protection – Power-supply cords should be routed so that they are not likely to be walked on or pinched by items placed upon or against them, paying particular attention to cords at plugs, convenience receptacles, and the point where they exit from the unit.
- 12 Cleaning – The unit should be cleaned only as recommended by the manufacturer.
- 13 Lightning – For added protection for this unit during a lightning storm, or when it is left unattended and unused for long periods of time, unplug it from the wall outlet and disconnect the antenna or cable system. This will prevent damage to the unit due to lightning and power-line surges.
- 14 Object and Liquid Entry – Care should be taken so that objects do not fall into and liquids are not spilled into the inside of the unit.
- 15 Damage Requiring Service – The unit should be serviced by qualified service personnel when:
 - A. The power-supply cord or the plug has been damaged; or
 - B. Objects have fallen, or liquid has been spilled into the unit; or
 - C. The unit has been exposed to rain; or
 - D. The unit does not appear to operate normally or exhibits a marked change in performance; or
 - E. The unit has been dropped, or the cabinet damaged.
- 16 Servicing – The user should not attempt to service the unit beyond those means described in the operating instructions. All other servicing should be referred to qualified service personnel.
- 17 Power Lines – An outdoor antenna should be located away from power lines.
- 18 Grounding or Polarization – Precautions should be taken so that the grounding or polarization is not defeated.

FCC INFORMATION (for US customers only)

1. IMPORTANT NOTICE : DO NOT MODIFY THIS UNIT!

This product, when installed as indicated in the instructions contained in this manual, meets FCC requirements. Modifications not expressly approved by Yamaha may void your authority, granted by the FCC, to use the product.

2. IMPORTANT : When connecting this product to accessories and/or another product use only high quality shielded cables. Cable/s supplied with this product **MUST** be used. Follow all installation instructions. Failure to follow instructions could void your FCC authorization to use this product in the USA.

3. NOTE : This product has been tested and found to comply with the requirements listed in FCC Regulations, Part 15 for Class "B" digital devices. Compliance with these requirements provides a reasonable level of assurance that your use of this product in a residential environment will not result in harmful interference with other electronic devices.

This equipment generates/uses radio frequencies and, if not installed and used according to the instructions found in the users manual, may cause interference harmful to the operation of other electronic devices.

Compliance with FCC regulations does not guarantee that interference will not occur in all installations. If this product is found to be the source of interference, which can be determined by turning the unit "OFF" and "ON", please try to eliminate the problem by using one of the following measures:

Relocate either this product or the device that is being affected by the interference.

Utilize power outlets that are on different branch (circuit breaker or fuse) circuits or install AC line filter/s.

In the case of radio or TV interference, relocate/reorient the antenna. If the antenna lead-in is 300 ohm ribbon lead, change the lead-in to coaxial type cable.

If these corrective measures do not produce satisfactory results, please contact the local retailer authorized to distribute this type of product. If you can not locate the appropriate retailer, please contact Yamaha Electronics Corp., U.S.A. 6660 Orangethorpe Ave, Buena Park, CA 90620.

The above statements apply **ONLY** to those products distributed by Yamaha Corporation of America or its subsidiaries.

We Want You Listening For A Lifetime

YAMAHA and the Electronic Industries Association's Consumer Electronics Group want you to get the most out of your equipment by playing it at a safe level. One that lets the sound come through loud and clear without annoying blaring or distortion – and, most importantly, without affecting your sensitive hearing.

Since hearing damage from loud sounds is often undetectable until it is too late, YAMAHA and the Electronic Industries Association's Consumer Electronics Group recommend you to avoid prolonged exposure from excessive volume levels.



UNPACKING

After unpacking, check that the following items are contained.

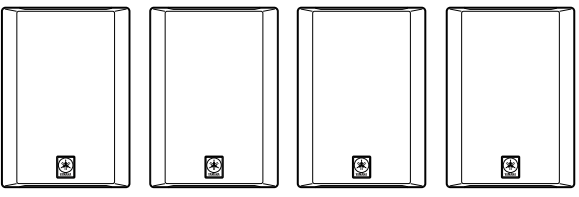
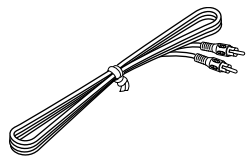
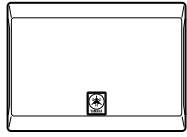
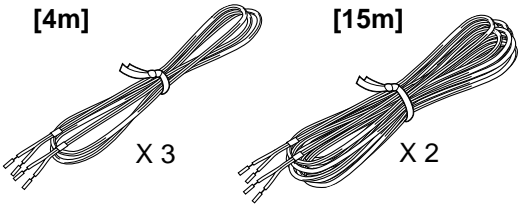
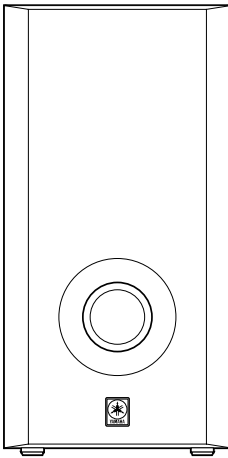
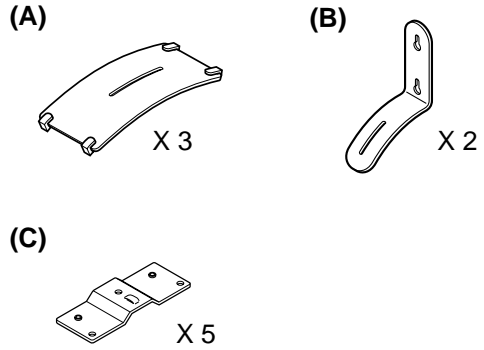
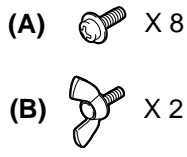
<ul style="list-style-type: none">● Main and rear speakers  <p><NX-220P> <NX-220P> <NX-220P> <NX-220P></p>	<ul style="list-style-type: none">● Audio connection cord 
<ul style="list-style-type: none">● Center speaker  <p><NX-C220></p>	<ul style="list-style-type: none">● Speaker cords <p>[4m] X 3</p> <p>[15m] X 2</p> 
<ul style="list-style-type: none">● Subwoofer  <p><SW-P201></p>	<ul style="list-style-type: none">● Mounting brackets <p>(A) X 3</p> <p>(B) X 2</p> <p>(C) X 5</p> 
	<ul style="list-style-type: none">● Screws <p>(A) X 8</p> <p>(B) X 2</p> 

CAUTION: Read this before operating your unit.

- To assure the finest performance, please read this manual carefully. Keep it in a safe place for future reference.
- Install the speakers in a cool, dry, clean place – away from windows, heat sources, sources of excessive vibration, dust, moisture and cold. Avoid sources of humming (transformers, motors). To prevent fire or electrical shock, do not expose the speakers to rain or water.
- To prevent the enclosure from warping or discoloring, do not place the speakers where they will be exposed to direct sunlight or excessive humidity.
- Do not place the following objects on the speakers:
Glass, china, etc.
If glass etc. falls by vibrations and breaks, it may cause personal injury.
A burning candle etc.
If the candle falls by vibrations, it may cause fire and personal injury.
A vessel with water in it
If the vessel falls by vibrations and water spills, it may cause damage to the speakers, and/or you may get an electric shock.
- Do not place the speakers where foreign objects such as water drips might fall. It might cause a fire, damage to the speakers, and/or personal injury.
- Do not place the speakers where they are liable to be knocked over or struck by falling objects. Stable placement will also ensure better sound performance.
- Placing the speakers on the same shelf or rack as the turntable can result in feedback.
- Any time you note distortion, reduce the volume control on your amplifier to a lower setting. Never allow your amplifier to be driven into “clipping”. Otherwise the speakers may be damaged.
- When using an amplifier with a rated output power higher than the nominal input power of the speakers, care should be taken never to exceed the speakers' maximum input.
- As these speakers contain strong magnets (though all of them are magnetically shielded types), avoid placing watches, magnetic tapes, etc. near them. Also, placing the speakers near a TV set may impair picture color. If this happens, move the speakers away from the TV set.
- Do not attempt to clean the speakers with chemical solvents as this might damage the finish. Use a clean, dry cloth.
- **Secure placement or installation is the owner's responsibility.**
YAMAHA shall not be liable for any accident caused by improper placement or installation of speakers.

For SW-P201 only

- Never open the cabinet. If something drops into the set, contact your dealer.
- Do not use force on switches, controls or connection wires. When moving the unit, first disconnect the power plug and the wires connected to other equipments. Never pull the wires themselves.
- Be sure to read the “TROUBLESHOOTING” section regarding common operating errors before concluding that the unit is faulty.

- When not planning to use this unit for a long period (ie., vacation, etc.), disconnect the AC power plug from the wall outlet.
- To prevent lightning damage, disconnect the AC power plug when there is an electric storm.
- Since this unit has a built-in power amplifier, heat will radiate from the rear panel. Place the unit apart from the walls, allowing enough space above, behind and on the both sides of the unit to prevent fire or damage. Furthermore, do not position with the rear panel facing down on the floor or other surfaces.

<For U.K. and Europe models only>

Be sure to allow a space of at least 20 cm above, behind and on both sides of the unit.

- Super-bass frequencies reproduced by this unit may cause a turntable to generate a howling sound. In such a case, move this unit away from the turntable.
- If you hear distorted noise (i.e., unnatural, intermittent “rapping” or “hammering” sounds) coming from this unit, reduce the volume level. Extremely loud playing of a movie soundtrack's low frequency, bass-heavy sounds or similarly loud popular music passages can damage this speaker system.

● VOLTAGE SELECTOR (General model only)

The **VOLTAGE SELECTOR** on the rear panel of this unit must be set for your local main voltage **BEFORE plugging into the AC main supply.**
Voltages are 110-120/220-240 V AC, 50/60 Hz.

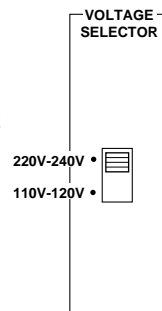

Standby mode

If the POWER switch is set to the ON position and the AUTO STANDBY switch is set to the HIGH or LOW position, this unit turns into the standby mode when no signal is inputted to this unit.

In this state, this unit is designed to consume a very small quantity of power.

WARNING

TO REDUCE THE RISK OF FIRE OR ELECTRIC SHOCK, DO NOT EXPOSE THIS UNIT TO RAIN OR MOISTURE.

For Canadian Customers

To prevent electric shock, match wide blade of plug to wide slot and fully insert.

This Class B digital apparatus complies with Canadian ICES-003.

For U.K. customers

If the socket outlets in the home are not suitable for the plug supplied with this appliance, it should be cut off and an appropriate 3 pin plug fitted. For details, refer to the instructions described below.

Note: The plug severed from the mains lead must be destroyed, as a plug with bared flexible cord is hazardous if engaged in a live socket outlet.

SPECIAL INSTRUCTIONS FOR U.K. MODEL

IMPORTANT:

THE WIRES IN MAINS LEAD ARE COLOURED IN ACCORDANCE WITH THE FOLLOWING CODE:

Blue: NEUTRAL

Brown: LIVE

As the colours of the wires in the mains lead of this apparatus may not correspond with the coloured markings identifying the terminals in your plug, proceed as follows: The wire which is coloured BLUE must be connected to the terminal which is marked with the letter N or coloured BLACK. The wire which is coloured BROWN must be connected to the terminal which is marked with the letter L or coloured RED. Making sure that neither core is connected to the earth terminal of the three pin plug.

COMPONENTS OF THE PACKAGE

The speaker package "NS-P220" is designed for use in a multi-channel audio system such as a home theater system. The package includes two pairs of main/rear speakers (NX-220P), a center speaker (NX-C220) and a subwoofer system (SW-P201).

<Main/rear speakers (NX-220P)>

2-way acoustic-suspension speaker system

<Center speaker (NX-C220)>

2-way acoustic-suspension speaker system

<Subwoofer (SW-P201)>

Active Servo Processing Subwoofer System with a built-in power amplifier

- This subwoofer system employs Advanced YAMAHA Active Servo Technology which YAMAHA has developed for reproducing higher quality super-bass sound. (Refer to page 12 for details on Advanced YAMAHA Active Servo Technology.) This super-bass sound adds a more realistic, theater-in-the-home effect to your stereo system.
- This subwoofer can be easily added to your existing audio system by connecting to either the speaker terminals or the line output (pin jack) terminals of the amplifier.
- The AUTO STANDBY switch saves you the trouble of setting the POWER switch to the ON or OFF position.

CONTENTS

SAFETY INSTRUCTIONS	II	How to connect speaker cords to the input and output terminals of the speakers	8
UNPACKING	IV	Connecting the subwoofer to speaker output terminals of the amplifier	9
CAUTION	1	USING THE SUBWOOFER (SW-P201)	10
COMPONENTS OF THE PACKAGE	2	Controls and their functions	10
SETTING UP THE SPEAKERS	3	Adjusting the subwoofer before use	11
Placing the subwoofer	3	ADVANCED YAMAHA ACTIVE SERVO TECHNOLOGY (for SW-P201)	12
Mounting the main and center speakers	4	TROUBLESHOOTING	13
Mounting the rear speakers	5	SPECIFICATIONS	14
CONNECTIONS	6		
An example of basic connections	6		

SETTING UP THE SPEAKERS

Before making connections, place all speakers in their respective positions. The positioning of the speakers is important because it controls the whole sound quality of this system.

Place the speakers depending on your listening position by following the instructions below.

Speaker configuration

This speaker package employs a 6 speaker configuration: 2 main speakers, 2 rear speakers, a center speaker and a subwoofer.

The main speakers are used for main source sound. The rear speakers are used for surround sounds, and the center speaker is for center sounds (dialog etc.). The subwoofer is for reinforcing low frequencies on your audio system.

Note

In this speaker package, the same speakers (NX-220P) are used for the main and rear speakers.

Placing speakers

Main speakers: On both sides of and at approximately the same height as the TV set.

Rear speakers: Behind your listening position, facing slightly inward. About 1.8 m (approx. 6 feet) from the floor.

Center speaker: Precisely between the main speakers.

Subwoofer: The position of the subwoofer is not so critical because low bass tones are not highly directional. Refer to "Placing the subwoofer" below for a recommended positioning of the subwoofer.

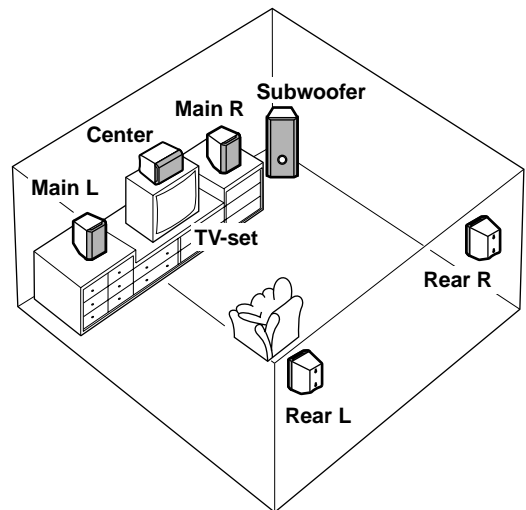
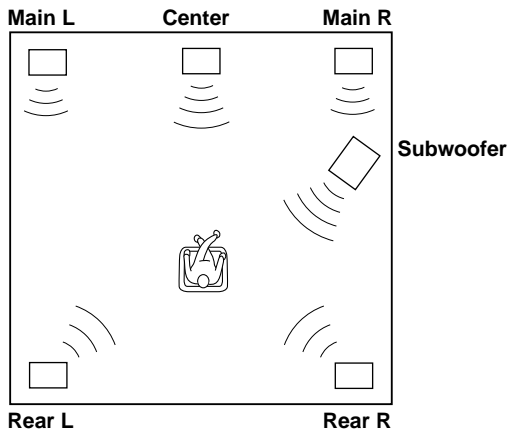

■ Placing the subwoofer

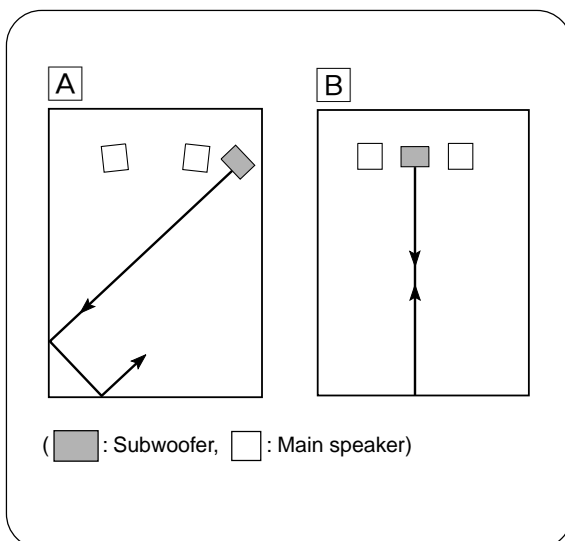

It is recommended to place the subwoofer on the outside of either the right or the left main speaker. (See fig. [A].) The placement shown in fig. [B] is also possible, however, if the subwoofer system is placed directly facing the wall, the bass effect may die because the sound from it and the sound reflected by the wall may cancel out each other. To prevent this from happening, face the subwoofer system at an angle as shown in fig. [A].

Note

There may be a case that you cannot obtain enough super-bass sounds from the subwoofer when listening in the center of the room. This is because "standing waves" have been developed between two parallel walls and they cancel the bass sounds.

In such a case, face the subwoofer obliquely to the wall. It also may be necessary to break up the parallel surfaces by placing bookshelves etc. along the walls.

■ Mounting the main and center speakers

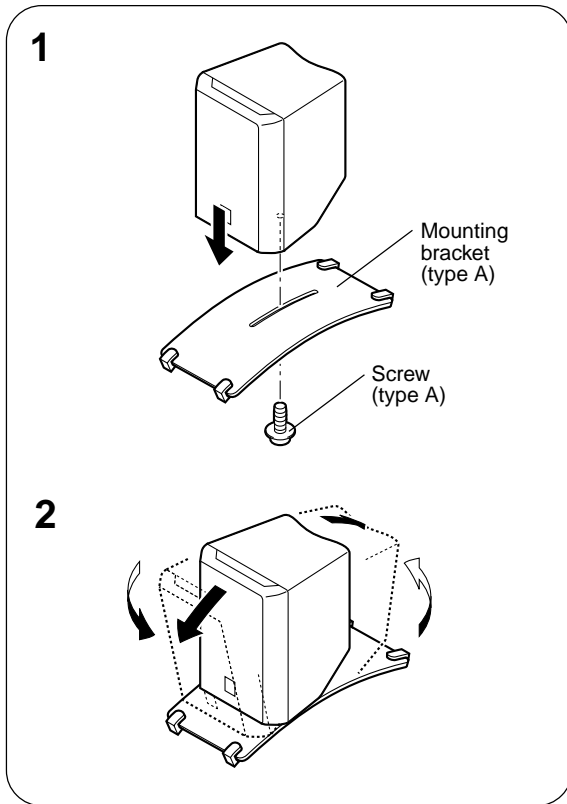

Place the main speakers on a rack or on a shelf. Place the center speaker on top of the TV, on a shelf or inside the TV rack so that it is stable.

To obtain more stability and usefulness, we recommend that you mount these speakers on the provided mounting brackets (type A).

To mount the speakers on the mounting brackets (type A)

- 1** Attach the bracket to the bottom of the speaker by using the provided screw (type A).
- 2** Turn and/or slide the speaker on the bracket according to your preference, and then tighten the screw.

Note

Though this speaker is a magnetically shielded type, there may be some influence on a TV picture depending on the type of TV or the placement of the speaker. In such a case, place the speaker apart from TV so that there is no influence on TV picture.

If you want to mount a speaker on a commercially available speaker stand (for the main/center/rear speakers)

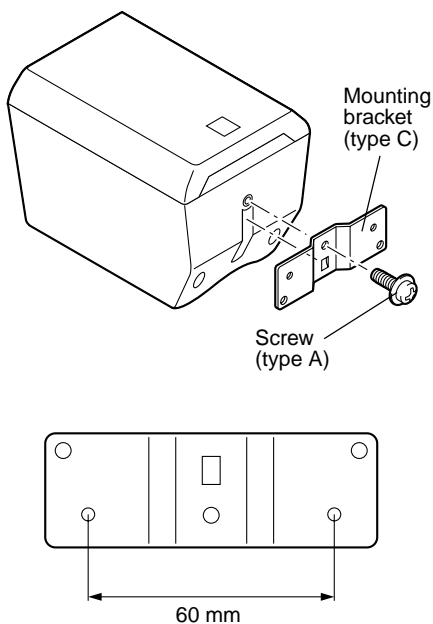

The provided mounting bracket (type C) with 1 pair of screw holes (at an interval of 60 mm) can be used to mount the speaker on a speaker stand.

* Those screw holes can be used with M4 screws only.

- 1** Attach the bracket to the bottom of the speaker by using the provided screw (type A) so that the convex part of the bracket fits in the grooved part on the bottom of the speaker as shown on the left.
- 2** Mount the speaker on the speaker stand by using the screw holes on the bracket.

Note

The mounting bracket (type C) is provided for each of 5 speakers.

■ Mounting the rear speakers

1

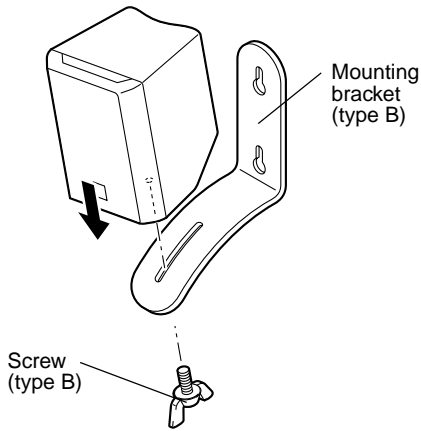

2

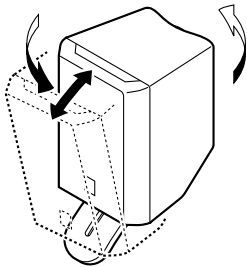

3

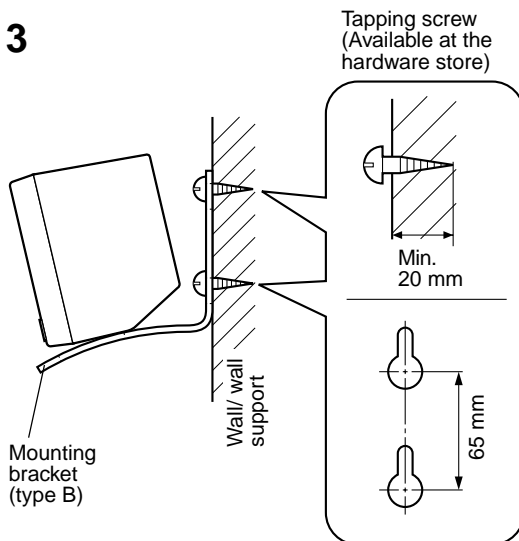

Mount the rear speakers on a shelf, rack or directly on the floor, or hang them on the wall.

To mount the rear speakers on a wall by using the provided mounting brackets (type B)

Note

It is recommended that you connect the speaker cords to the speaker's terminals before attaching the bracket to the speaker.

- 1 Attach the bracket to the bottom of the speaker by using the provided screw (type B).
- 2 Turn and/or slide the speaker on the bracket according to your preference, and then, tighten the screw.
- 3 Fasten screws into a firm wall or wall support as shown in the figure, and hang the holes of the mounting bracket on the protruding screws.
 - * Make sure that the screws are securely caught by the narrow parts of the holes.

Note

If desired, you can hang the speaker directly on the protruding screws on the wall without using the bracket.

WARNING

- Each speaker weighs 0.7 kg (1 lbs. 9 oz.). Do not mount them on thin plywood or a wall with soft surface material. If mounted, the screws may come out of the flimsy surface and the speakers may fall. This damages the speakers or causes personal injury.
- Do not install the speakers to a wall with nails, adhesives, or any other unstable hardware. Long-term use and vibrations may cause them to fall.
- To avoid accidents resulting from tripping over loose speaker cords, fix them to the wall.
- Select a proper position on the wall to mount the speaker and the bracket so that no one will injure his/her head or face with the edge of the bracket.

CONNECTIONS

Caution: Plug in the subwoofer and other audio/video components after all connections are completed.

■ An example of basic connections

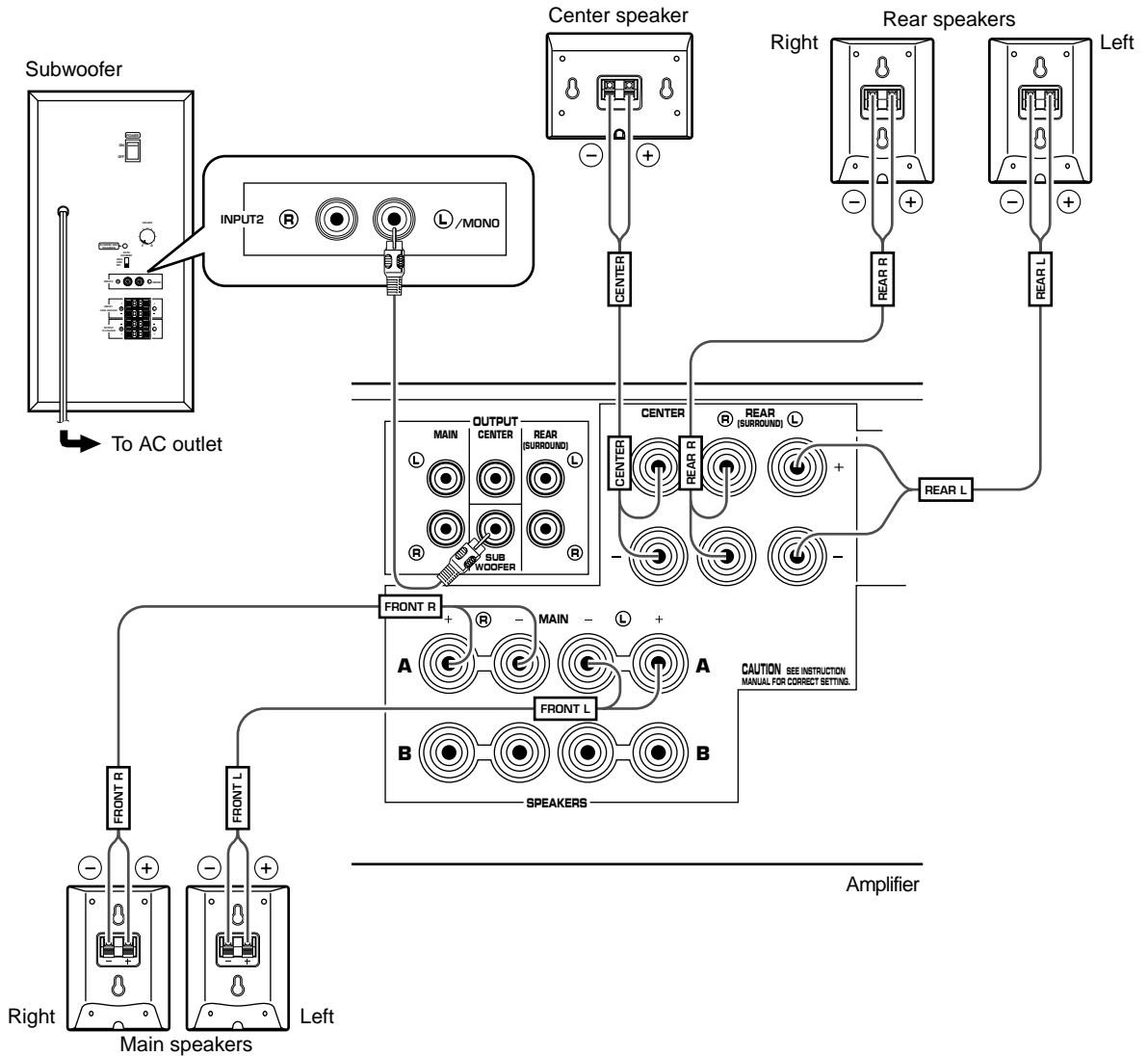

- Connect the main, center and rear speakers to the speaker output terminals of your amplifier with the provided speaker cords.
 - * The provided speaker cords have labels marked FRONT L, FRONT R, CENTER, REAR L or REAR R. Connect each speaker cord to the corresponding speaker by following the figure on page 6.
 - * Connect each speaker making sure not to reverse the polarity (+, -). If the speaker is connected with reversed polarity, the sound will be unnatural and lack bass.
 - * For the main and rear speakers only, connect one speaker to the left (marked L) terminals of your amplifier, and another speaker to the right (marked R) terminals.

- Basically, connect the subwoofer to the line output (pin jack) terminal(s) of the amplifier. If your amplifier does not have any line output terminal, connect the subwoofer to the speaker output terminals of the amplifier. (Refer to page 9 for details.)
 - * To connect with a YAMAHA DSP amplifier (or AV receiver), connect the SUBWOOFER (or LOW PASS etc.) terminal on the rear of the DSP amplifier (or AV receiver) to the **L**/MONO INPUT2 terminal of the subwoofer.
 - * To connect the subwoofer to the SPLIT SUBWOOFER terminals on the rear of the DSP amplifier, connect them to both the left **L** and right **R** INPUT2 terminals of the subwoofer.

Note

When connecting to a monaural line output terminal of the amplifier, connect the **L**/MONO INPUT2 terminal.

■ How to connect speaker cords to the input and output terminals of the speakers

For connections, keep the speaker cords as short as possible. Do not bundle or roll up the excess part of the cords. If the connections are faulty, no sound will be heard from the speakers.

Main/center/rear speakers

One side of the provided speaker cord has a white broken line and the other side has no line.

Connect the (+) terminals on both the speaker and the amplifier using the side with a white broken line. Connect the (-) terminals on both components using the side with no line.

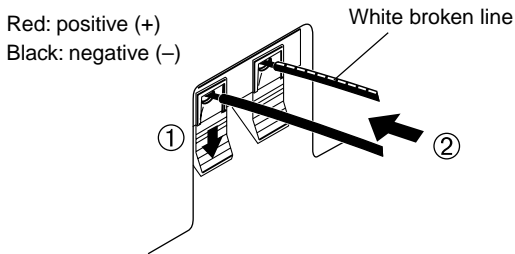

How to Connect:

- ① Press and hold the terminal's tab, as shown in the figure.
- ② Insert the bare wire end properly into the terminal hole. [Remove approx. 10 mm (3/8") insulation from the speaker cord.]

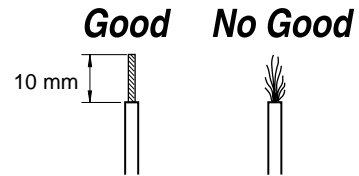

- ③ Release your finger from the tab to allow it to lock securely on the cord's wire end.
- ④ Test the firmness of the connection by pulling lightly on the cord at the terminal.

Subwoofer (INPUT1/OUTPUT terminals)

Connect the (+) terminals on both the subwoofer and the amplifier using one side of the cord. Connect the (-) terminals on both components using the other side of the cord.

Red: positive (+)
Black: negative (-)

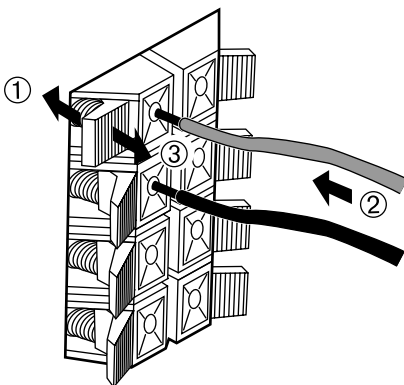

Note

Do not let the bare speaker wires touch each other as this could damage the speaker or the amplifier, or both of them.

■ Connecting the subwoofer to speaker output terminals of the amplifier

If your amplifier has only one set of main speaker output terminals

Connect the speaker output terminals of the amplifier to the INPUT1 terminals of the subwoofer, and connect the OUTPUT terminals of the subwoofer to the main speakers.

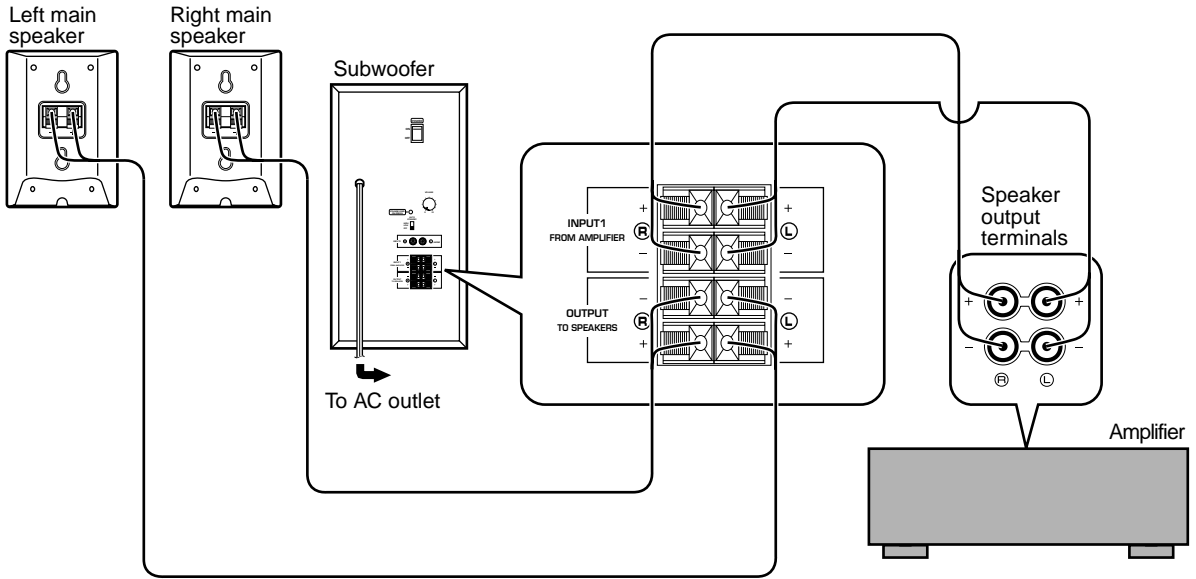

If your amplifier has two sets of speaker output terminals

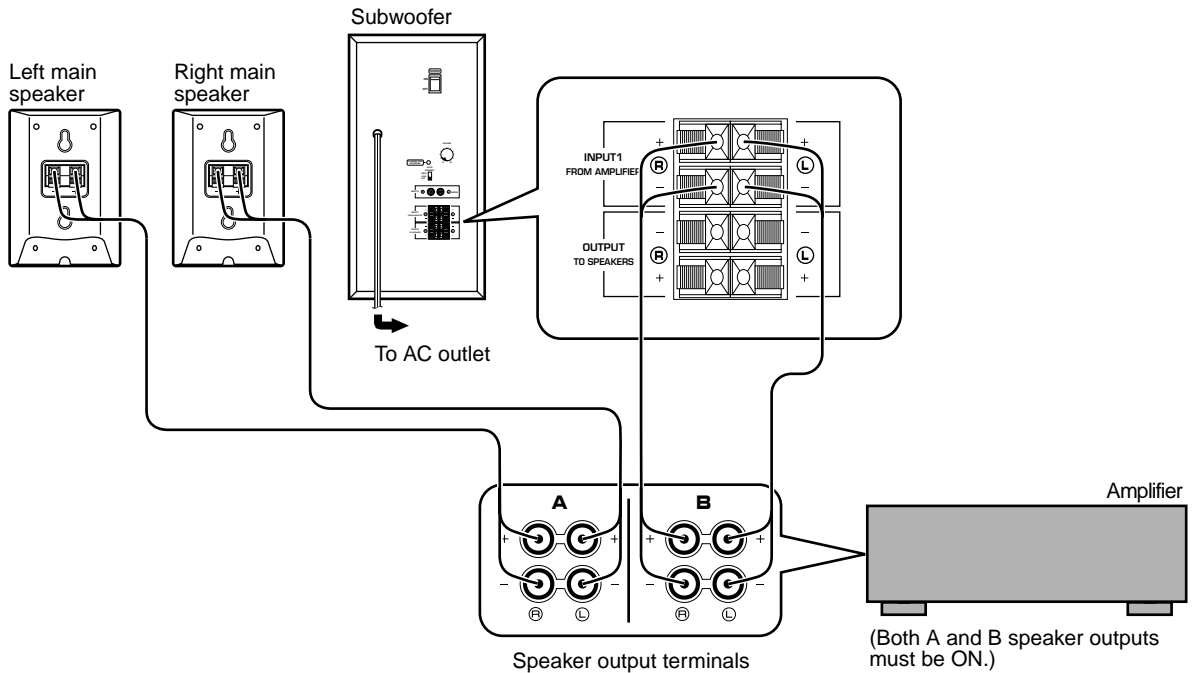

USING THE SUBWOOFER (SW-P201)

■ Controls and their functions

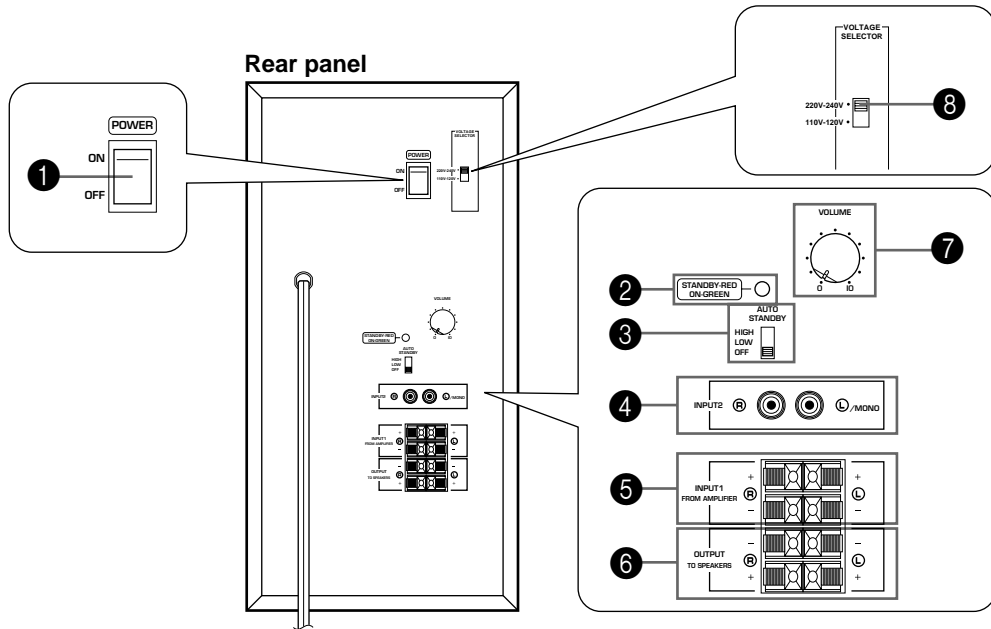

1 POWER switch

Set this switch to the ON position to turn on the power of the subwoofer. When the power of the subwoofer is on, the power indicator below the **POWER** switch lights up GREEN. Set this switch to the OFF position to turn off the power of the subwoofer.

2 Power indicator

Lights up GREEN when the **POWER** switch is set to the ON position and goes off when set to the OFF position.

* Standby mode

If the **POWER** switch is set to the ON position and the **AUTO STANDBY** switch is set to the HIGH or LOW position, this indicator lights up RED when no signal is inputted to the subwoofer.

3 AUTO STANDBY (HIGH/LOW/OFF) switch

By setting this switch to the HIGH or LOW position, the subwoofer's automatic power-switching function operates as described on the next page. If you do not need this function, set to the OFF position.

* Make sure to change the setting of this switch only when the **POWER** switch (1) is in the OFF position.

4 INPUT2 terminals

Used to input line level signals from the amplifier.

5 INPUT1 (FROM AMPLIFIER) terminals

Used to connect the subwoofer with the speaker terminals of the amplifier.

6 OUTPUT (TO SPEAKERS) terminals

Can be used for connecting to the main speakers. Signals from the **INPUT1** terminals (5) are sent to these terminals.

7 VOLUME control

Adjusts the volume level.

8 VOLTAGE SELECTOR switch (General model only)

If the preset setting of the switch is incorrect, set the switch to the proper voltage range (220V-240V or 110V-120V) of your area.

Consult your dealer if you are unsure of the correct setting.

WARNING

Be sure to unplug the subwoofer before setting the VOLTAGE SELECTOR switch correctly.

Standby mode

The subwoofer is still using a small amount of power in this mode.

Automatic power-switching function

If the source being played is stopped and the input signal is cut off for 7 to 8 minutes, the subwoofer automatically switches to the standby mode. (When the subwoofer switches to the standby mode, the power indicator lights up in red.)

When you play a source again, the power of the subwoofer turns on automatically by sensing audio signals input to the subwoofer.

This function operates by sensing a certain level of low frequency input signal. Usually set the **AUTO STANDBY** switch to the LOW position. However, if the power is not switched to ON or STANDBY smoothly, set the switch to the HIGH position. In the HIGH position, the power will turn on even with a low level of input signal. But please be aware that the subwoofer may not switch to the standby mode when there is an extremely low input signal.

* The power might turn on unexpectedly by sensing noise from other appliances. If that occurs, set the **AUTO STANDBY** switch to the OFF position and use the **POWER** switch to switch the power between ON and OFF manually.

* This function detects the low-frequency components below 200 Hz of the input signals (i.e., the explosion in the action movie, the sound of the bass guitar or the bass drum, etc.).

* The minutes required to switch the subwoofer to the standby mode might change by sensing noise from other appliances.

This function is available only when the power of the subwoofer is on (by setting the POWER switch (1) to "ON").

■ Adjusting the subwoofer before use

Before using the subwoofer, adjust the subwoofer to obtain the optimum volume balance between the subwoofer and the main speakers by following the procedures described below.

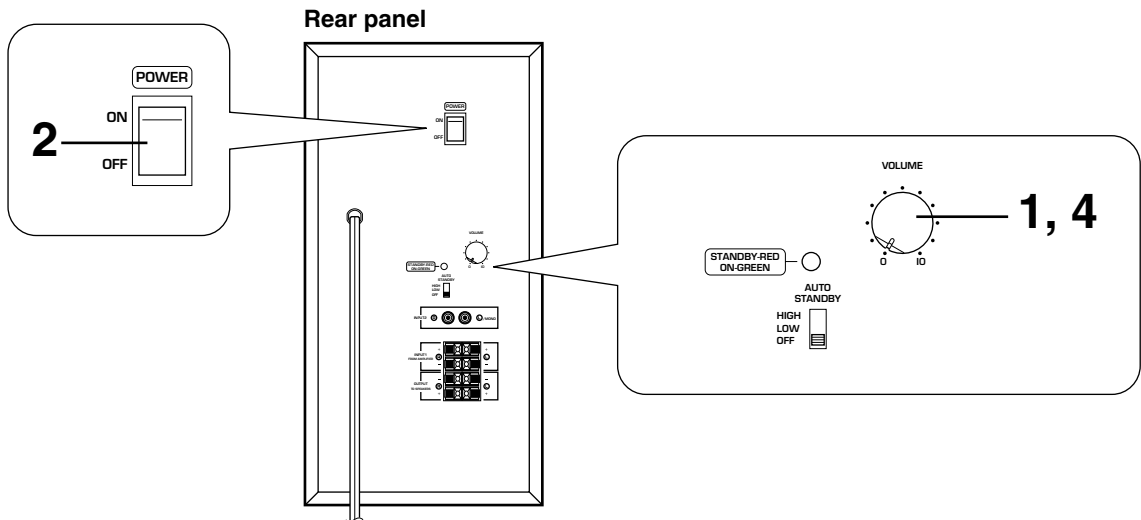

- 1 Set the **VOLUME** control to minimum (0).
- 2 Turn on the power supply to all the components.
- 3 Play a source and adjust the amplifier's volume control to the desired listening level.
- 4 Increase the volume gradually to adjust the volume balance between the subwoofer and the main speakers.

Note: It is recommended to set the **VOLUME** control to the middle position when using all the speakers of this package in a 5.1-channel home theater system.

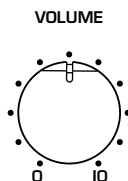

Once the volume balance between the subwoofer and the main speakers is adjusted, you can adjust the volume of your whole sound system by using the amplifier's volume control.

However, if you change the main speakers NX-220P to others, you must make this adjustment again.

ADVANCED YAMAHA ACTIVE SERVO TECHNOLOGY (for SW-P201)

The theory of Yamaha Active Servo Technology has been based upon two major factors, the Helmholtz resonator and negative-impedance drive. Active Servo Processing speakers reproduce the bass frequencies through an "air woofer", which is a port or opening in the speaker's cabinet. This opening is used instead of, and performs the functions of, a woofer in a conventionally designed speaker system. Thus, signals of low amplitude within the cabinet can, according to the Helmholtz resonance theory, be outputted from this opening as waves of great amplitude if the size of the opening and the volume of the cabinet are in the correct proportion to satisfy a certain ratio.

In order to accomplish this, moreover, the amplitudes within the cabinet must be both precise and of sufficient power because these amplitudes must overcome the "load" presented by the air that exists within the cabinet.

Thus it is this problem that is resolved through the employment of a new design in which the amplifier supplies special signals. If the electrical resistance of the voice coil could be reduced to zero, the movement of the speaker unit would become linear with respect to signal voltage. To accomplish this, a special negative-impedance output-drive amplifier for subtracting output impedance of the amplifier is used.

By employing negative-impedance drive circuits, the amplifier is able to generate precise, low-amplitude, low-frequency waves with superior damping characteristics. These waves are then radiated from the cabinet opening as high-amplitude signals. The system can, therefore, by employing the negative-impedance output drive amplifier and a speaker cabinet with the Helmholtz resonator, reproduce an extremely wide range of frequencies with amazing sound quality and less distortion.

The features described above, then, are combined to be the fundamental structure of the conventional Yamaha Active Servo Technology.

Our new Active Servo Technology — Advanced Yamaha Active Servo Technology — adopted Advanced Negative Impedance Converter (ANIC) circuits, which allows the conventional negative impedance converter to dynamically vary in order to select an optimum value for speaker impedance variation. With this new ANIC circuits, Advanced Yamaha Active Servo Technology can provide more stable performance and improved sound pressure compared with the conventional Yamaha Active Servo Technology, resulting in more natural and dynamic bass reproduction.

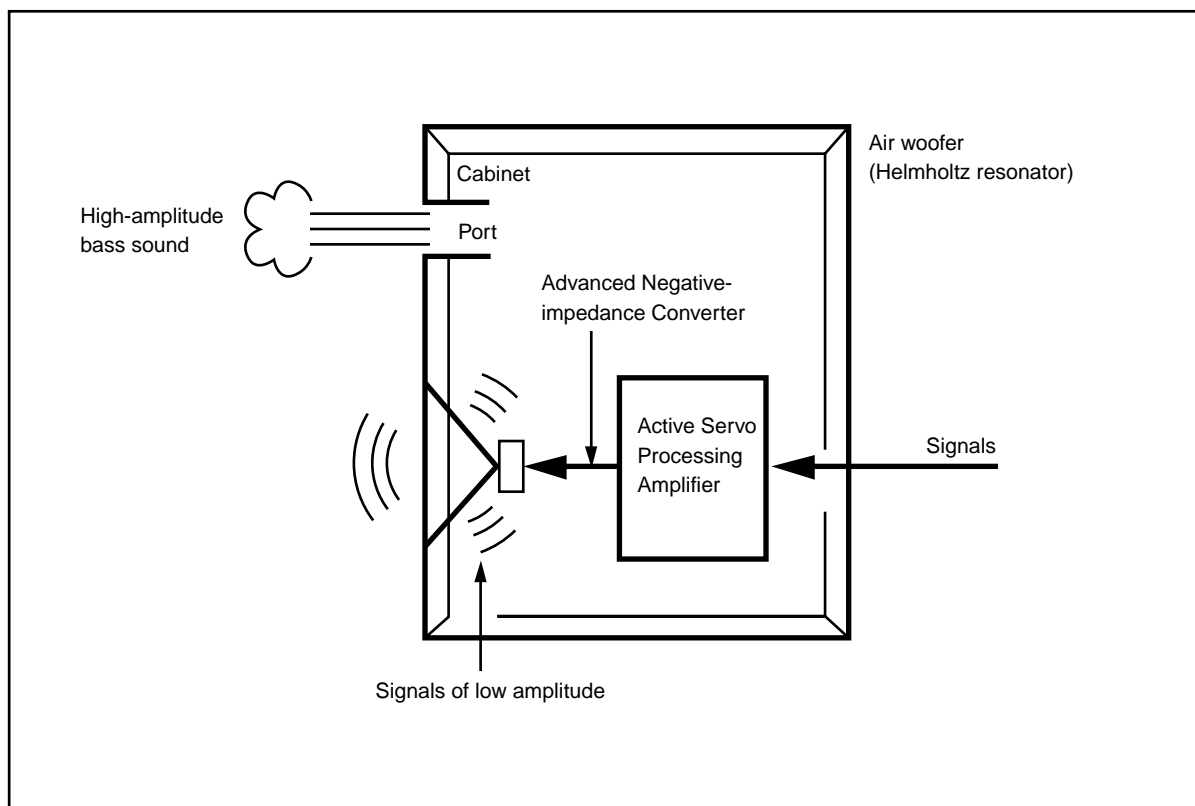

TROUBLESHOOTING

Refer to the chart below when this unit does not function properly. If the problem you are experiencing is not listed below or if the instructions given below do not help, disconnect the power cord and contact your authorized YAMAHA dealer or service center.

Problem	Cause	What to Do
No sound.	Speaker cords are not connected securely.	Connect them securely.
Sound level is too low.	Speaker cords are not connected correctly.	Connect them correctly, that is L (left) to L, R (right) to R, "+" to "+" and "-" to "-".

For SW-P201

Problem	Cause	What to Do
Power is not supplied even though the POWER switch is set to the ON position.	The power plug is not securely connected.	Connect it securely.
No sound.	The VOLUME control is set to 0.	Turn the VOLUME control to the right.
	Speaker cords are not connected securely.	Connect them securely.
Sound level is too low.	Speaker cords are not connected correctly.	Connect them correctly, that is L (left) to L, R (right) to R, "+" to "+" and "-" to "-".
	A source sound with few bass frequencies is played.	Play a source sound with bass frequencies.
	It is influenced by standing waves.	Reposition the subwoofer or break up the parallel surface by placing bookshelves etc. along the walls.
The subwoofer will not turn on automatically.	The POWER switch is set to the OFF position.	Set the POWER switch to the ON position.
	The AUTO STANDBY switch is set to the OFF position.	Set the AUTO STANDBY switch to the "HIGH" or "LOW" position.
	The level of input signal is too low.	Set the AUTO STANDBY switch to the "HIGH" position.
The subwoofer turns into the standby mode unexpectedly.	The level of input signal is too low.	Set the AUTO STANDBY switch to the "HIGH" position.
The subwoofer turns on unexpectedly.	There is an influence of noise generated from external appliances etc.	Move the subwoofer farther away from such appliances and/or reposition the connected speaker cables. Otherwise, set the AUTO STANDBY switch to the "OFF" position.

SPECIFICATIONS

NX-220P, NX-C220

Type 2-way acoustic-suspension speaker system
Magnetically shielded type

Driver 8 cm (3-1/8") cone type
1.9 cm (3/4") balanced dome type

Nominal Input Power 30W

Maximum Input Power 100W

Impedance 6Ω

Frequency Response 140 Hz–27 kHz

Sensitivity 86 dB/2.83V/m

Dimensions (W x H x D)

<NX-220P> 100 mm x 140 mm x 113 mm
(3-15/16" x 5-1/2" x 4-7/16")

<NX-C220> 140 mm x 100 mm x 112 mm
(5-1/2" x 3-15/16" x 4-7/16")

Weight

<NX-220P> 0.7 kg (1 lbs. 9 oz.) x 4

<NX-C220> 0.7 kg (1 lbs. 9 oz.)

SW-P201

Type Advanced Yamaha Active Servo Technology

Driver 16 cm (6-5/16") cone woofer (JA1678)
Magnetically shielded type

Amplifier Output 50W/5Ω

Frequency Response 30 Hz–200 Hz (–10 dB)

Power Supply

USA and Canada models AC 120V, 60 Hz

U.K. and Europe models AC 230V, 50 Hz

Australia model AC 240V, 50 Hz

General model AC 110-120/220-240V, 50/60 Hz

Power Consumption 42W
(In the standby mode: 6W)

Dimensions (W x H x D) 200 mm x 395 mm x 384 mm
(7-7/8" x 15-9/16" x 15-1/8")

Weight 9.3 kg (20 lbs. 7 oz.)

Accessories Audio connection cord x 1
Speaker cord [4 m (13.1 feet)] x 3
Speaker cord [15 m (49.2 feet)] x 2
Mounting bracket (type A) x 3
Mounting bracket (type B) x 2
Mounting bracket (type C) x 5
Screw (type A) x 8
Screw (type B) x 2

* Please note that all specifications are subject to change without notice.



YAMAHA ELECTRONICS CORPORATION, USA 6660 ORANGETHORPE AVE., BUENA PARK, CALIF. 90620, U.S.A.
YAMAHA CANADA MUSIC LTD. 135 MILNER AVE., SCARBOROUGH, ONTARIO M1S 3R1, CANADA
YAMAHA ELECTRONIK EUROPA G.m.b.H. SIEMENSSTR. 22-34, 25462 RELLINGEN, BEI HAMBURG, F.R. OF GERMANY
YAMAHA ELECTRONIQUE FRANCE S.A. RUE AMBROISE CROIZAT BP70 CROISSY-BEAUBOURG 77312 MARNE-LA-VALLEE CEDEX02, FRANCE
YAMAHA ELECTRONICS (UK) LTD. YAMAHA HOUSE, 200 RICKMANSWORTH ROAD WATFORD, HERTS WD1 7JS, ENGLAND
YAMAHA SCANDINAVIA A.B. J A WETTERGRENS GATA 1, BOX 30053, 400 43 VASTRA FRÖLUNDA, SWEDEN
YAMAHA MUSIC AUSTRALIA PTY, LTD. 17-33 MARKET ST., SOUTH MELBOURNE, 3205 VIC., AUSTRALIA

YAMAHA CORPORATION
Printed in China  V742370-1