



QUIK LOK[®]

STANDS APART FROM THE REST

2020
PRODUCT CATALOGUE

EKO MUSIC
GROUP

SINCE 1959 THE SAME PASSION



QUIK LOK[®]

STANDS APART FROM THE REST

QUIK-LOK is a famous brand known worldwide, due to its reliability, creativity and innovative abilities in providing new solutions to meet musicians' problems. **QUIK-LOK** was able to gain an important market share throughout its many years of experience in the music field, offering high quality products, designed and manufactured to excellent standards, and ensuring the best service, after sales assistance and complete customer satisfaction at all times.

Welcome to **QUIK-LOK**!

This catalogue was compiled so as to guarantee an easy and efficient research for those who wish to know more about **QUIK-LOK**. Border pages vary in color according to the category of the product being searched. In any case, we will be happy to hear your comments and suggestions in order to improve this instrument of research.

INDEX

-  KEYBOARD STANDS & ACCESSORIES
-  STOOLS & BENCHES
-  MICROPHONE STANDS & ACCESSORIES
-  SHEET MUSIC STANDS
-  SPEAKER & LIGHTING STANDS
-  GUITAR STANDS
-  ORCHESTRA INSTRUMENT STANDS
-  MULTI FUNCTION STANDS
-  AMPLIFIER STANDS
-  RACK EQUIPMENT STANDS & RACK ACCESSORIES
-  MIXER STANDS
-  WORKSTATIONS & COMPUTER FURNITURE
-  DISPLAY STANDS
-  CARTS
-  PEDALS
-  ASSEMBLED CABLES
-  BULK CABLES
-  INDEX



STANDS APART FROM THE REST

Quik Lok is a division of Eko Music Group SpA

QUIKLOK.IT



DAL 1959 LA STESSA PASSIONE

Technical data and appearance of products are subject to change without prior notice.

This catalogue issue supersedes any previous one.

KEYBOARD
STANDS & ACCESSORIES

andstage



SL/930 DOUBLE-TIER KEYBOARD SLANT STAND WITH FULLY ADJUSTABLE TIERS



- Solid steel construction provides maximum sturdiness and ensures excellent structural support.
- Exclusive, patented foldable design of tiers and base allows to set up and fold down the stand in a snap, with no loose parts, to a very compact size for convenient storage and easy transport.
- Fully adjustable tiers can be quickly set at either one of 14 height positions and 5 angle positions, and feature telescoping depth to accommodate virtually any size keyboard and controller up to 14.9" (38 cm) deep, as well as drum machines and sound modules.
- Stylish, contemporary base design provides plenty of room for volume, sustain and control pedals.
- Perfect solution for home studio and live performance, the SL930 slant stand offers an ideal option for in-store display applications as well.
- A complete line of options and accessories, including second tier add-ons, a mic boom arm and a sheet music holder, a laptop and a tablet holder, allows the user to customize the SL/930 stand to perfectly fit their needs
- Non-reflective, powder-coating black enamel finish.
- Includes nylon carrying bag and one Z/735 accessory clamp required for connection of optional accessories (can be easily removed if not needed).

SL/930

- Double-tier keyboard slant stand with fully adjustable tiers

Leg depth:	24.4" - 62 cm
Base width:	31.5" - 80 cm
Front to back footprint:	28.7" - 73 cm
Stand height:	51.6" - 131 cm
Tiers usable depth range:	10.6" to 14.9" 27 to 38 cm
Tiers height positions (14):	26.8" to 51.2" 68 to 130 cm
Tiers angle positions:	5
Weight capacity:	220 lb - 99 kg
Weight:	25.3 lb - 11.40 kg
Color:	Black

Options: SL/931, A/386, QLX/4, QLX/5, LPH/X, IPS/13, Z/735



Folds to a very compact size for convenient storage and easy transport



Nylon carrying bag included



Includes 3/8" and 5/8" threaded connection for mic boom attachment



Stylish rubber levelling feet ensure max stability and no-wobbly playing on uneven floors



Fully adjustable tiers can be quickly set at either one of 14 height positions and 5 angle positions, and feature telescoping depth to accommodate any size keyboard and controller up to 14.9" (38 cm) deep. Once tiers are properly positioned they can be securely locked in place by tightening the stability knob (pictured on right).

SL/931

- Angle, height & depth adjustable tier add-on for SL/930 Slant Stand

Tier usable depth range: from 12.6" to 16.1" from 32 to 41 cm
 Weight capacity: 75 lb - 33.8 kg
 Weight: 6.2 lb - 2.8 kg
 Color: Black



Z/735

- Accessory clamp for use with SL/930 Slant Stand
- Required for connection (at any one of 14 height positions available) to stand column of optional add-ons model QLX/4, QLX/5, LPH/X, IPS/13
- Also suitable for use with any of Quik Lok's Z-Series keyboard stands

Weight: 0.73 lb - 0.33 kg
 Color: Black



SL/913ALU ALL-ALUMINUM DOUBLE-TIER KEYBOARD SLANT STAND

- Solid **ALL-ALUMINUM** construction guarantees amazing lightness while ensuring maximum sturdiness and excellent structural support.
- Exclusive, ingenious, patented design of tiers and base, made of high-grade quality die-cast aluminum, allows to set up the stand for your gig in just a few seconds, and instantly tear it down to a very compact, portable size for convenient storage and easy transport.
- Height adjustable tiers can be quickly set at the most suitable height position for playing both standing and seated in absolute comfort, and will securely accommodate most size keyboards and controllers, as well as drum machines, small mixers and sound modules.
- Stylish, contemporary, raised base design provides plenty of room for volume, sustain and control pedals.
- Perfect solution for home studio and live performance, the SL913ALU slant stand offers an ideal option for in-store display applications as well.
- Supplied with convenient cable management clips.
- Offered in a wide assortment of high-tech metallic finishes.
- Includes nylon carrying bag with dedicated inner compartments to safely stow tiers and feet.

SL/913ALU BL

- All-Aluminum, Full-size, double-tier keyboard slant stand
- Designed for use with up to 76-note keyboards and controllers, as well as drum machines, mixers and sound modules
- Includes nylon carrying bag and a 3/8" or 5/8" threaded connection clamp for microphone boom add-ons

Base depth:	24.8" - 63 cm
Base width:	36.81" - 93.5 cm
Stand height:	46.85" - 119 cm
Tiers height adjustability:	from 26.7" to 46.8" from 68 to 119 cm
Lower tiers angle:	Straight 90° fixed angle
Lower tiers length:	17.71" - 45 cm
Lower tiers usable depth:	15.74" - 40 cm
Upper tiers angle:	Fixed 10° tilt angle
Upper tiers length:	14.96" - 38 cm
Upper tiers usable depth:	11.8" - 30 cm
Folded size:	5.9" x 7.87" x 46.45" 15 x 20 x 118 cm
Weight capacity:	240 lb - 108 kg (80 lb - 36 kg per tier)
Weight:	13.11 lb - 5.9 kg
Color:	Metallic Blue

Options: SL/914ALU



Includes a 3/8" or 5/8" threaded connection clamp for microphone boom add-ons





SL/913ALU SL
Color: Metallic Silver

SL/913ALU WH
Color: Metallic White



SL/913ALU BK
Color: Metallic Black

SL/913ALU RE
Color: Metallic Red

SL/914ALU

- Aluminum, height-adjustable long tier add-on for SL913ALU stand
- Designed to accommodate up to 76-note keyboards and larger equipment and sound modules

Tiers angle:	Fixed 10° tilt angle
Tiers length:	14.96" - 38 cm
Tiers usable depth:	11.8" - 30 cm
Color:	Black



Keyboard Stands & Accessories

M/61 LARGE, HEAVY DUTY SINGLE-TIER KEYBOARD STRUCTURE

- Thanks to its original design, incorporating width-adjustable tiers that expand from 11.02" to 34.65" (28 to 88 cm) to conform to the exact size of your equipment, the M/61 is an extremely versatile stand, suitable for multiple applications.
- Heavy duty construction, the sturdy frame is built to hold the heaviest and largest of keyboards and digital pianos safely and securely, but is also ideal for medium size live mixers, DJ coffins, recording and audio equipment up to 25" (64 cm) deep.
- 10 height adjustment positions, from 27.56" to 38.18" (70 to 97 cm), are easily achievable by means of Quik Lok's spring-loaded security pin device, making it extremely comfortable for playing while sitting or standing.
- Grants maximum leg room for comfortable playing, providing a large open area for placement of floor pedals.
- Solid rubber rest pads hold your equipment firmly in place.
- Simple but ingenious design allows to set up and fold down both tiers and legs in a snap, so that the stand folds flat to a very compact size for easy transport and storage.
- Exclusive rotating levelling feet compensate for uneven stage floors, avoiding any sort of inconvenient wobble.
- Easily expandable to fit musicians' needs, by adding any of the available QUIK-LOK accessories, including second tier add-ons, a mic boom arm and a sheet music holder, a laptop and a tablet holder.

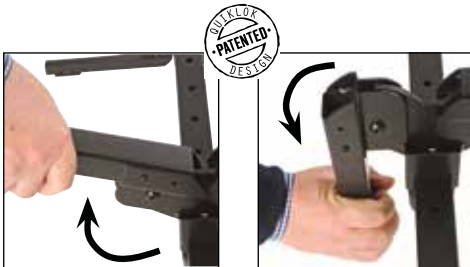

Tiers and legs can be set up and can fold down in a snap!!!

M/61

- Large, Heavy Duty, Single-Tier Keyboard Structure

Height positions (10):	27.56" to 38.18" (in increments of 1.18") 70 to 97 cm (in increments of 3 cm)
Frame width:	42.51" - 108 cm
Frame depth:	26" - 66 cm
Tiers width positions (7):	11.02" to 34.65" (in increments of 3.93") 28 to 88 cm (in increments of 10 cm)
Tiers depth:	16.9" - 43 cm
Folded dimensions:	42.51"x7.68"x27.16" 108 x 19.5 x 69 cm
Frame tubing size:	35 x 35 mm
Weight Capacity:	200 lb - 90 kg
Weight:	21.1 lb - 9.5 kg
Color:	Black

Options: QLX/3, QLX/4, QLX/5, IPS/13, LPH/X



M/61 stand complete with QLX/4 mic boom arm, LPH/X laptop holder and MS/327 headphone holder



Ingenious design allows to set up and fold down both tiers and legs in a snap, for easy transport and storage.



Details of levelling foot and rubber rest pad

M/91 “THE MONOLITH”, SINGLE-TIER KEYBOARD STRUCTURE

- Quik-Lok announces a breakthrough in keyboard stand development never before seen.
- The “MONOLITH” represents all of the requirements of today’s keyboard players by incorporating a blend of form, functionality and lightweight portability.
 - Form:** A revolutionary patent-pending design concept developed by a team of Italian engineers and designers.
 - Function:** The unencumbered shape allows keyboard players to freely perform without any restrictions.
 - Foldable:** Form and function are combined in a stand that literally folds flat and locks in seconds to a compact transportable size.
- Other key features that make the Monolith the most complete keyboard stand ever developed:
 - Height adjustable tiers
 - Computer-welded, lightweight steel

M/91

- “THE MONOLITH” Single-Tier Keyboard Structure

Front to back top tier depth: 14.56” - 37 cm
 Front to back bottom leg depth: 16.53” - 42 cm
 Side to side width: 33.46” - 85 cm
 Top to bottom height positions: from 26.2” to 36”
 from 66.5 to 91.5 cm
 Weight capacity: 200 lb - 90 kg
 Weight: 23.3 lb - 10.5kg
 Color: Black

Options: M/2



FOLDABLE

Form and function are combined in a stand that literally folds flat and locks in seconds to a compact, transportable size

M/2

- Tilt, Height & Depth Adjustable Second Tier Add-on for M/91
- Rubber-coated tier arms hold keyboards firmly in place
- Securely attaches to main keyboard tier of the M/91

Front to back tier depth measurement: 12.6” - 32.1 cm
 2nd tier height positions: from 8.8” to 12.2”
 from 22.5 to 31 cm
 Weight capacity: 75 lb - 33.9 kg
 Weight: 6.6 lb - 3 kg
 Color: Black



M/91 keyboard stand complete with M/2 second tier add-on

Keyboard Stands & Accessories

WS/421 HEAVY DUTY, FULLY ADJUSTABLE KEYBOARD STRUCTURE

- The WS/421 is an extremely versatile stand, designed for multiple applications.
- Heavy duty construction, the sturdy frame is built to hold the heaviest of keyboards and digital pianos safely and securely.
- Ideal for small live mixers, DJ coffins, recording and audio equipment.
- Height adjustable to 12 different positions from 25.6" to 37.8" (65 to 96 cm), the WS/421 is also width expandable from 25.2" to 39.4" (64 to 100 cm) to conform to the exact size of your equipment.
- Grants maximum leg room for comfortable playing, providing a large open area for placement of floor pedals.
- Folds flat to a very compact size for easy transport and storage.
- Easily expandable to fit musicians' needs by adding any of the available QUIK-LOK accessories.



WS/421

- Portable, heavy duty, width and height adjustable keyboard/mixer stand with foldable legs



Height positions (12):	25.6" to 37.8" 65 to 96 cm
Usable width range:	25.2" to 39.4" 64 to 100 cm
Usable depth:	11.8" - 30 cm
Folded dimensions:	27.9" x 14.6" x 5.3" 71 x 37 x 13.5 cm
Frame tubing size:	30 mm
Weight Capacity:	178 lb - 80 kg
Weight:	18 lb - 8 kg
Color:	Black

Options: WS/422, QLX/4*, QLX/5*, LPH/X*, IPS/13*

* Note: can be used only in combination with WS/422 add-on tiers

WS/421 folds flat and locks rapidly to a compact, transportable size



WS/422

- Angle, height & tilt adjustable tier add-on for use with WS/421 keyboard stand

Tier depth:	11.8" - 30 cm
Weight capacity:	75 lb - 33.8 kg
Weight:	6.66 lb - 3 kg
Color:	Black



WS/421 keyboard stand complete with WS/422 second tier add-on

QLY/40 PROFESSIONAL “Y”-STYLE SINGLE-TIER, HEIGHT ADJUSTABLE, RAPID SET-UP, COMPLETELY FOLDABLE KEYBOARD STRUCTURE

QLY/40

- Single-Tier, fully adjustable “Y”-style Stand with foldable base and tiers

Base depth:	17.3" - 44 cm
Base width:	36" - 91.5 cm
Height positions (7):	from 28.7" to 37" from 73 to 94 cm
Tier depth:	14.5" - 37 cm
Tier width positions (7):	from 25.6" to 35.4" from 65 to 90 cm
Tier diameter:	30 mm
Upright legs tube size:	35x35 mm
Fold-up size:	33" x 9.4" x 5.9" 84 x 24 x 15 cm
Weight capacity:	220 lb - 99 kg
Weight:	20.66 lb - 9.3 kg
Color:	Black

Options: QLY/42, QLX/4, QLX/5, LPH/X, IPS/13



QLY/40 keyboard stand shown with LPH/X optional laptop holder



Exclusive, patented foldable design of tiers and base allows to instantly fold down the stand to a very compact size for convenient storage and transport



Pull-out floor metal stabilizers provided to grant extra stability to stand and safety to gear when playing on uneven floors.



Supplied with nylon carrying bag

QLY/42

- Angle, height & tilt adjustable tier add-on for QLY/40 Keyboard Stand

Tier depth:	11.8" - 30 cm
Weight capacity:	75 lb - 33.8 kg
Weight:	6.2 lb - 2.8 kg
Color:	Black



QLY/40 keyboard stand complete with QLY/42 second tier add-on



NEW "PRO SERIES" LINE OF HEAVY DUTY KEYBOARD "X" STANDS

- The absolute hands down choice of most professional musicians for home studio and live performance because of their adjustability, functionality, strength and reliability.
- Built using heavy duty 30x30 mm dual steel tube bracing for extra sturdiness and structural support, the new "PRO Series" stands are capable of holding the heaviest keyboards safely and securely.
- This high-tech line of stands features "The Original" locking disc system, redesigned to incorporate the new user-friendly pull-lever device that allows musicians to instantly open and close the stand, setting it at any one of 5 positive-lock height adjustment positions.
- The innovative, advanced-technology upper tier set found on the double and triple tier stand models incorporates newly designed, high-precision zinc-alloy discs that make it fully adjustable in height, angle, tilt and depth, to offer the musician maximum flexibility of use.
- Sleek, stylish rotating levelling foot and rest pad compensate for uneven floors and keyboards.
- Supplied with convenient cable management clips.
- A complete line of accessories allows musicians to customize their performance structure to accommodate their needs perfectly.



QL/723

- Professional heavy-duty, double-brace, triple-tier "X" keyboard stand with height, angle, tilt and depth adjustable upper tier set

Leg depth:	24" - 61 cm
Main tier depth:	17.2" - 43.5 cm
Main tier height positions (5):	26.8", 30.9", 34.4", 37.2", 39"
	68, 78.5, 87.5, 94.5, 99 cm
2nd & 3rd tier depth:	16.5" - 42 cm
2nd tier height position:	6.7" - 17 cm
	*[measured from main tier level]
3rd tier height positions (3):	7.1" - 7.8" - 8.6"
	*[measured from 2nd tier level]
2nd & 3rd tier angles:	90°, 77°, 64°, 51°
Folded height:	39.8" - 101 cm
Overall weight capacity:	200 lb - 90 kg
2nd & 3rd tier weight capacity:	60 lb - 27 kg
Weight:	26.7 lb - 12 kg
Brace tube size:	30 x 30 mm (x2)
Main tier tube size:	30 mm
Color:	Black

Options: QLX/4, QLX/5, IPS/13



QL/742

- Professional heavy-duty, double-brace, double-tier "X" keyboard stand with height, angle, tilt and depth adjustable tier set



The innovative, advanced-technology upper tier set found on the QL/742 and QL/723 incorporates newly designed, high-precision zinc-alloy discs that make it fully adjustable in height, angle, tilt and depth, to offer the musician maximum flexibility of use

Leg depth:	24" - 61 cm
Main tier depth:	17.2" - 43.5 cm
Main tier height positions (5):	26.8", 30.9", 34.4", 37.2", 39", 68, 78.5, 87.5, 94.5, 99 cm
Second tier depth:	16.5" - 42 cm
2nd tier height positions (5):	from 5.7" to 8.8"
*(measured from main tier level)	from 14.5 to 22.5 cm
Second tier angles:	90°, 77°, 64°, 51°
Folded height:	39.8" - 101 cm
Overall weight capacity:	200 lb - 90 kg
2nd tier weight capacity:	75 lb - 33.7 kg
Weight:	20.7 lb - 9.3 kg
Brace tube size:	30 x 30 mm (x2)
Main tier tube size:	30 mm
Color:	Black

Options: QLX/3, QLX/4, QLX/5, LPH/X, IPS/13



QL/746

- Professional heavy duty, double-brace, single-tier "X" keyboard stand



Leg depth:	26" - 66 cm
Tier depth:	20" - 50.8 cm
Height positions (5):	23", 27.8", 32", 34.5", 38", 58.5, 70.6, 81.2, 89.8, 96.4 cm
Folded height:	40.4" - 102.7 cm
Weight capacity:	260 lb - 117 kg
Weight:	20 lb - 9 kg
Brace tube size:	30 x 30 mm (x2)
Tier tube size:	30 mm
Color:	Black

Options: QLX/3, QLX/4, QLX/5, QL/662, LPH/X, IPS/13



Quik Lok's new, user-friendly pull-lever device allows musicians to instantly open and close the stand, setting it at any one of 5 positive-lock height adjustment positions



Keyboard Stands & Accessories

“PERFORMER SERIES” CLASSIC LINE OF HEAVY DUTY KEYBOARD “X” STANDS

- Built using heavy duty 30x30 mm dual steel tube bracing for extra sturdiness and structural support, the “PERFORMER Series” stands are capable of holding the heaviest keyboards safely and securely.
- Perfect solution for home studio and live performance because of their adjustability, functionality, strength and reliability, the “PERFORMER Series” stands offer an ideal option for in-store display applications as well.
- This high-tech line of stands features “The Original” locking disc system, redesigned to incorporate the new user-friendly pull-lever device that allows musicians to instantly open and close the stand, setting it at any one of 5 positive-lock height adjustment positions.
- The upper tier set found on the double and triple tier stand models incorporates our exclusive “Lok-Tight” gripping system with steel ratchet joints, originally designed by Quik Lok to become an industry standard across the world for many years now.
- The QL/623 triple-tier keyboard stand features angle and tilt adjustable upper tiers, while the QL/642 double-tier performance structure is fully adjustable in height, angle, tilt and depth, to offer the musician maximum flexibility of use.
- Sleek, stylish rotating levelling foot and rest pad compensate for uneven floors and keyboards.
- Supplied with convenient cable management clips
- A complete line of accessories allows musicians to customize their performance structure to accommodate their needs perfectly.



QL/623

- Heavy duty, double-brace “X” with angle & tilt adjustable second & third tier

Leg depth:	26” - 66 cm
Main Tier depth:	17.9” - 42.5 cm
Main tier height positions (5):	23”, 27.8”, 32”, 34.5”, 38”
	58.5, 70.6, 81.2, 89.8, 96.4 cm
2nd & 3rd Tier depth:	12” - 30.5 cm
2nd & 3rd Tier angles:	90°, 81°, 72°, 63°, 54°
Folded height:	40.4” - 102.7 cm
Overall Weight capacity:	265 lb - 120kg
2nd tier weight capacity:	60 lb - 27 kg
3rd tier weight capacity:	60 lb - 27 kg
Weight:	28.9 lb - 13 kg
Brace tube size:	30 x 30 mm (x2)
Tiers tube size:	30 mm
Color:	Black

Options: QLX/4, QLX/5, IPS/13

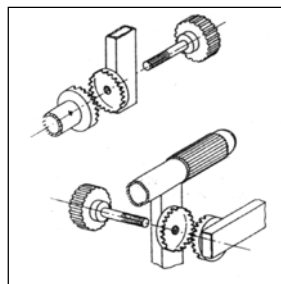

The upper tier set found on the QL/642 and QL/623 models incorporates our exclusive “Lok-Tight” gripping system with steel ratchet joints, originally designed by Quik Lok to soon become an industry standard across the world.



QL/642

- Heavy duty, double-brace "X" with height angle, tilt and depth adjustable second tier



Details of QL/642 fully adjustable tiers with depth alignment position markers.

Leg depth:	26" - 66 cm
Main Tier depth:	17.9" - 42.5 cm
Main tier height positions (5):	23", 27.8", 32", 34.5", 38"
	58.5, 70.6, 81.2, 89.8, 96.4 cm
Second Tier depth:	15.8" - 41 cm
Second Tier angles:	90°, 77°, 64°, 51°
Folded height:	40.4" - 102.7 cm
Overall Weight capacity:	265 lb - 120 kg
2nd tier weight capacity:	75 lb - 33.7 kg
Weight:	22.2 lb - 10 kg
Brace tube size:	30 x 30 mm (x2)
Main tier tube size:	30 mm
Color:	Black

Options: QLX/3, QLX/4, QLX/5, LPH/X, IPS/13



QL/646

- Double-brace, single-tier "X"



Leg depth:	20" - 50.8 cm
Tier depth:	13.75" - 34.9 cm
Height positions (5):	23", 27.4", 31.2", 34.5", 36.6"
	58.4, 69.6, 79.3, 87.7, 93.1 cm
Folded height:	38.75" - 98.5 cm
Weight capacity:	200 lb - 90 kg
Weight:	10.6 lb - 4.8 kg
Brace tube size:	30 x 15 mm (x2)
Tier tube size:	30 mm
Color:	Black

Options: QLX/3, QLX/4, QLX/5, QL/662, LPH/X, IPS/13



“TRIGGER-LOK” SERIES OF HEAVY DUTY KEYBOARD “X” STANDS



- The ingenious “TRIGGER-LOK” system designed by QUIK-LOK houses five positive-lock height positions and is completely sealed exposing no parts.
- The mechanism allows the user to instantly open and close the stand from the top tiers without having to push or pull any knobs or buttons on the center disc, but simply squeezing the trigger and releasing it once the stand is positioned at the desired height.
- Constructed using heavy duty 30 x 30 mm steel tubing for extra sturdiness and structural support, these stands are strong enough to hold keyboards up to 200 lb (90 kg).
- Sleek, stylish rotating levelling foot and rest pad compensate for uneven floors and keyboards.
- A complete line of options and accessories, including second tier add-ons, a mic boom arm and a sheet music holder, a laptop and a tablet holder, allows the user to customize any stand to fit their needs at best.



T/500

- Heavy duty, single-brace, single-tier “X” keyboard stand with “Trigger-Lok” height adjustment system

Leg depth:	19.8" - 50.4 cm
Tier depth:	15.9" - 40.5 cm
Folded height:	39.7" - 101 cm
Brace tube size:	30 x 30 mm
Tier tube size:	30 mm
Weight capacity:	180 lb - 81 kg
Weight:	8.8 lb - 4 kg
Color:	Black

Options: QL/662, QLX/3, QLX/4, QLX/5, LPH/X, IPS/13



T/500 in use with QLX/3 add-on tiers

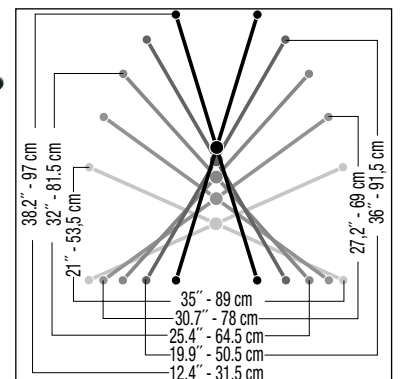

T/500 & T/550
Height & width positions

T/550

- Heavy duty, double-brace, single-tier "X" keyboard stand with "Trigger-Lok" height adjustment system

Leg depth:	19.8" - 50.4 cm
Tier depth:	15.9" - 40.5 cm
Folded height:	39.7" - 101 cm
Brace tube size:	30 x 30 mm (x2)
Tier tube size:	30 mm
Weight capacity:	200 lb - 90 kg
Weight:	13.5 lb - 6.1 kg
Color:	Black

Options: QL/662, QLX/3, QLX/4, QLX/5, LPH/X, IPS/13



T/550 in use with optional iPad holder



New, stylish rotating levelling foot and rest pad compensate for uneven floors and keyboards, for comfortable, wobble-free playing



Open-end rubber rest pads adjust to accommodate different keyboard depths, and allow to retrofit any of the add-on options available to this stand series



The Trigger-Lok system allows to open and close the stand from the top tiers by simply squeezing the trigger and releasing it once the stand is positioned at the desired height

Keyboard Stands & Accessories

“T-REX” FLAGSHIP LINE OF KEYBOARD “X” STANDS FEATURING THE “DINO-BITE” LOCKING DISC

- After many years of unparalleled success and worldwide popularity, Quik Lok is glad to announce the restyling of their two best selling keyboard “X”-stand models, the T/10 and T/20 single-tier stands, now redesigned to incorporate new, stylish and contemporary features.
- At the heart of all “T-REX” stands is the renowned “DINO-BITE” all-steel locking disc.
- Solidly constructed with high-grade steel for consistent high-quality and years of reliability, by virtue of the new enhanced aesthetics and increased functionality, the “T-REX” line of keyboard stands now offers more value to musicians than ever before!
- Adjustments are made easily by simply loosening the center knob, moving to any one of the 9 usable, non-slip height adjustment positions, and then re-tightening.
- Rotating levelling foot and rest pad compensate for uneven floors and keyboards.
- A complete line of options and accessories, including second tier add-ons, a mic boom arm and a sheet music holder, a laptop and a tablet holder, allows the user to customize any stand to fit their needs at best.



T/10

- Full sized, single-brace, single-tier “X” keyboard stand

Leg depth:	18.2" - 46.3 cm
Tier depth:	14.1" - 35.7 cm
Folded height:	38.6" - 98 cm
Brace tube size:	30 mm x 20 mm
Tier tube size:	30 mm
Weight capacity:	160 lb - 72 kg
Weight:	8.45 lb - 3.8 kg
Color:	Black

Options: QL/662, QLX/3, QLX/4, QLX/5, LPH/X, IPS/13

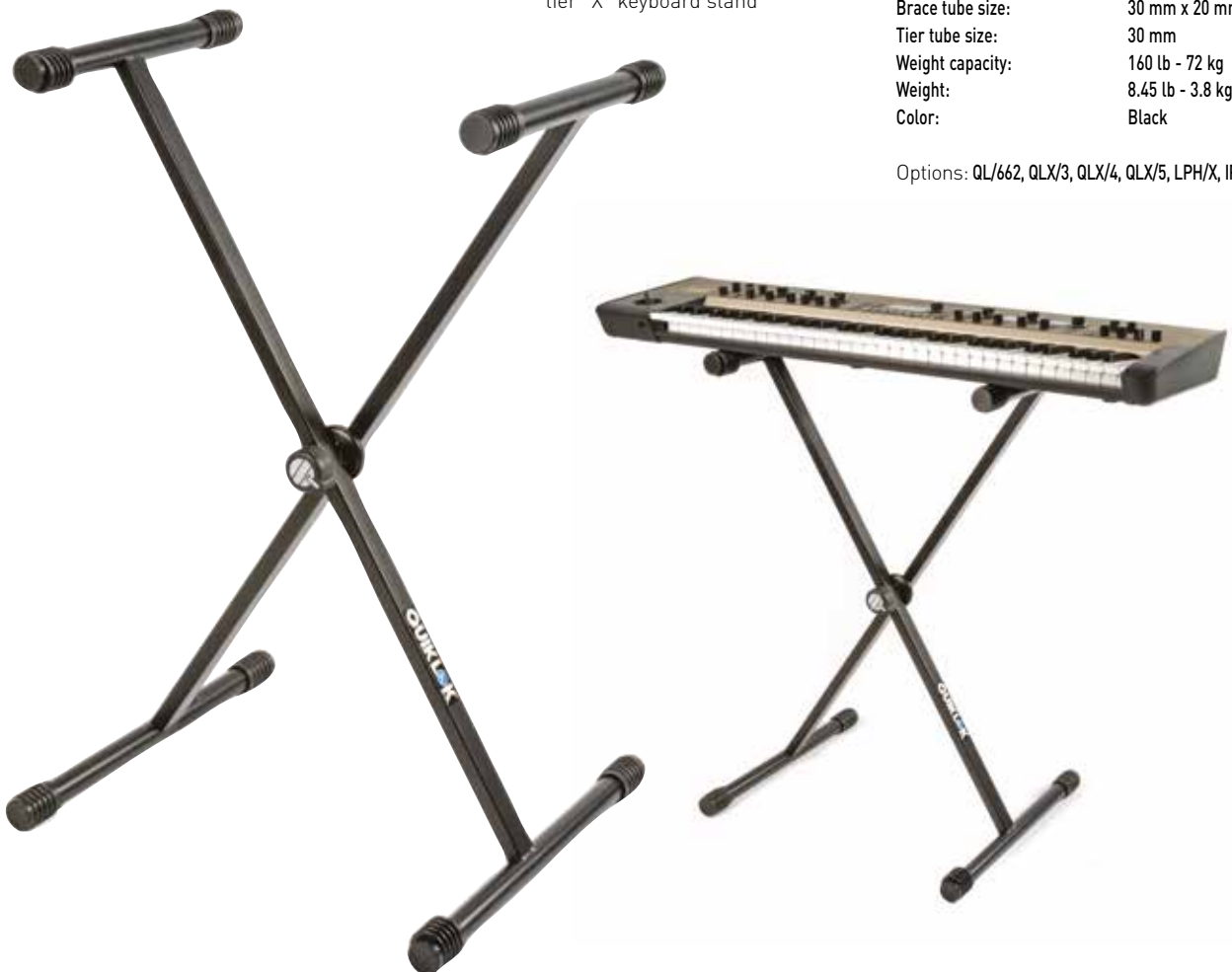

T/20

- Full sized, double-brace, single-tier "X" keyboard stand

Leg depth:	18.2" - 46.3 cm
Tier depth:	14" - 35.7 cm
Folded height:	38.6" - 98 cm
Brace tube size:	30 mm x 15 mm (x2)
Tier tube size:	30 mm
Weight capacity:	180 lb - 81 kg
Weight:	10.4 lb - 4.7 kg
Color:	Black

Options: QL/662, QLX/3, QLX/4, QLX/5, LPH/X, IPS/13

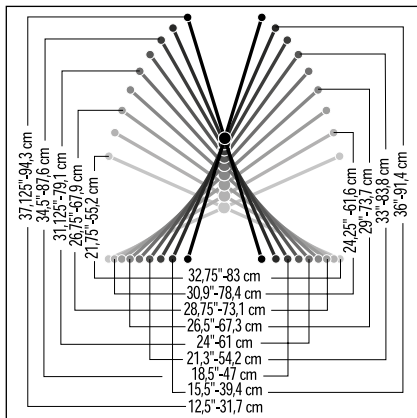

T/10 - T/20
Height & width positions



The new, sleek, user-friendly Quik Lok center knob allows to easily set the stand to anyone of 9 usable, non-slip height adjustment positions



New, stylish rotating levelling foot and rest pad compensate for uneven floors and keyboards, for comfortable, wobble-free playing



Open-end rubber rest pads adjust to accommodate different keyboard depths, and allow to retrofit any of the add-on options available to this stand series

Keyboard Stands & Accessories



T/22

- Double-brace "X" keyboard stands with tilt and angle adjustable second tier

Leg depth:	18.5" - 47 cm
Main tier depth:	13.8" - 35 cm
Second tier depth:	12.2" - 31 cm
Folded height:	40.5" - 102 cm
Overall weight capacity:	180 lb - 81 kg
2nd tier weight capacity:	75 lb - 33.7 kg
Weight:	20 lb - 9 kg
Brace tube size:	30 x 15 mm (x2)
Tier tube size:	30 mm
Color:	Black

Options: QLX/4, QLX/5, IPS/13

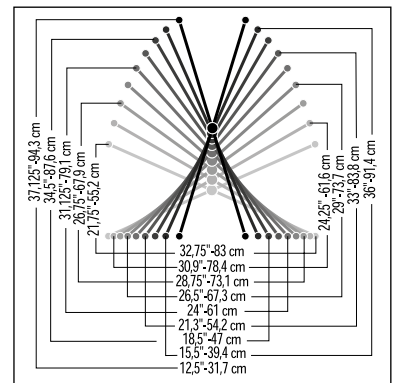

T/22 Height & width positions



QL/322

- Micro table top "X" stand used for holding 25 to 49 note keyboards on elevated surfaces such as table tops, computer furniture, pianos or organs.

Leg depth:	9.75" - 24.8 cm
Tier depth:	9.75" - 24.8 cm
Folded height:	13.1" - 33.4 cm
Weight capacity:	100 lb - 45 kg
Weight:	3.1 lb - 1.4 kg
Brace tube size:	20 x 15 mm
Tier tube size:	25 mm
Color:	Black

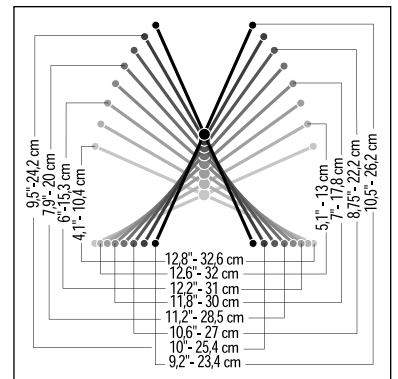

QL/322 Height & width positions

QUIKLOK®

STANDS APART FROM THE REST



I T A L I A N



D E S I G N

Keyboard Stands & Accessories

NEW T/6 and T/6KD KEYBOARD “X” STANDS FEATURING THE “ELLIPSE” NYLON LOCKING DISC

- Quik-Lok introduces the new T/6 and T/6KD single-tier, single-brace keyboard stands, incorporating the “ELLIPSE” superstrong open & close nylon disc mechanism.
- Featuring an esthetically appealing contoured shape, yet high mechanical strength at the same time, the new injection-molded nylon locking disc ensures max stability and sturdiness.
- Adjustments are made easily by simply loosening the center knob, moving to any one of the 9 usable, non-slip height adjustment positions, and then re-tightening.
- Solidly constructed with high-grade steel and computer-welded joints for consistent high-quality and years of reliability.
- Rotating levelling foot and rest pad compensate for uneven floors and keyboards.
- A complete line of options and accessories, including second tier add-ons, a mic boom arm and a sheet music holder, a laptop and a tablet holder, allows the user to customize any stand to fit their needs.



T/6

- Full sized, single-brace, single-tier “X” keyboard stand

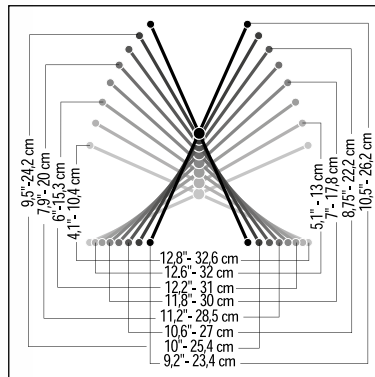

T/6 & T/6KD height and width positions

Leg depth:	18.2" - 46.3 cm
Tier depth:	14.1" - 35.7 cm
Folded height:	38.6" - 98 cm
Brace tube size:	30 mm x 20 mm
Tier tube size:	30 mm
Weight capacity:	160 lb - 72 kg
Weight:	8.45 lb - 3.8 kg
Color:	Black

Options: QL/662, QLX/3, QLX/4, QLX/5, LPH/X, IPS/13



The new, sleek, user-friendly Quik Lok center knob allows to easily set the stand to anyone of 9 usable, non-slip height adjustment positions



New, stylish rotating levelling foot and rest pad compensate for uneven floors and keyboards, for comfortable, wobble-free playing



Open-end rubber rest pads adjust to accommodate different keyboard depths, and allow to retrofit any of the add-on options available to this stand series

T/6KD

- Collapsible, full sized, single-brace, single-tier "X" keyboard stand
- Knock-Down version of the standard T/6 model, folds flat to an extremely compact, space-saving size for easy storage and transport

Leg depth:	18.2" - 46.3 cm
Tier depth:	14.1" - 35.7 cm
Folded height:	38.6" - 98 cm
Disassembled size:	37.4" x 7.1" x 2.8"
	95 x 18 x 7 cm
Brace tube size:	30 mm x 20 mm
Tier tube size:	30 mm
Weight capacity:	80 lb - 36 kg
Weight:	7.1 lb - 3.2 kg
Color:	Black

Options: QL/662, QLX/4, IPS/13



The T/6KD collapsible stand comes folded flat to an extremely compact, space-saving size (37.4" x 7.1" x 2.75" - 95 x 18 x 7 cm) for easy storage and transport



When disassembled, special rubber joints are used to hold all four tiers and legs tightly connected to the stand's main frame, so as to avoid them getting damaged or lost during transport: even when knocked-down, there are no parts to lose!



Mounting bolts required to fasten all four tiers and legs to the stand's main frame are equipped with nutlocks to ensure they always stay firmly in place and to prevent them from being misplaced even when the T/6KD stand is disassembled



Tiers and legs can be bolted onto the stand's main frame in a snap using the supplied hexagonal key. Once the T/6KD stand is set up for use, the same rubber joints prove to be very helpful as cable management channels



Keyboard Stands & Accessories

BS/619 HEAVY DUTY KEYBOARD "X" STAND WITH "THE ORIGINAL" QUIK LOK LOCKING DISC SYSTEM

- The BS/619 features "The Original" QUIK LOK locking disc system with "T"-pull handle, a battle-tested device that has been accepted as the industry standard since 1978.
- Constructed using super heavy duty 30x30 mm steel tube bracing for extra sturdiness and structural support, the BS/619 is capable of holding the heaviest keyboards safely and securely.
- Uniquely designed to incorporate collapsible, telescopic tiers that can be independently height adjusted, this stand excels in versatility, strength and durability.
- A complete line of options, including second tier add-ons, a mic boom arm and a sheet music holder, a laptop and a tablet holder, allows the user to customize this stand.



BS/619

- Portable full-sized keyboard "X" stand with collapsible telescopic tiers

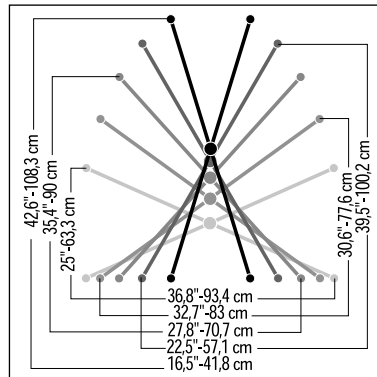

BS/619 Height & width positions

Leg depth:	19.5" - 49.5 cm
Tier depth:	13.75" - 34.9 cm
Folded height:	28" - 71 cm
Weight capacity:	180 lb - 81 kg
Weight:	9.5 lb - 4.3 kg
Upper brace tube size:	25 x 25 mm
Lower brace tube size:	30 x 30 mm
Tier tube size:	30 mm
Colour:	Black

Options: QLX/3, QLX/4, QLX/5, QL/662, LPH/X, IPS/13



BS/619 with QLX/3 add-on tiers folded down becomes the smallest available double keyboard stand on the market

SKS/303 X-STYLE SINGLE TIER, SINGLE BRACED KEYBOARD STAND



SKS/303

- X-style single tier, single braced keyboard stand
- Featuring essential but practical half-moon locking disc system, it can be easily adjusted to 4 different height positions by means of a simple, user-friendly spring-loaded pull-knob



Leg depth:	19.9" - 48.5 cm
Tier depth:	13.38" - 34 cm
Height positions (4):	25.2", 29.5", 33", 36", 64, 75, 84, 91.5 cm
Folded height:	39.37" - 100 cm
Brace tube size:	30 x 15 mm
Tier tube size:	25 mm
Weight capacity:	88.9 lb - 40 kg
Weight:	5.46 lb - 2.46 kg
Color:	Black

Options: none are available for this model

GET A SYSTEM! NOT JUST ANOTHER “X” STAND WITH THE COMPLETE LINE OF QUIK LOK ADD-ONS



- When you buy a Quik Lok stand, you just don't buy any “X” stand, you invest in a system!
- This system can be configured in a variety of ways to fit any keyboard players' needs.
- A complete assortment of options are available for the entire “X” series keyboard stands offered by Quik Lok.
- A new, strong, non-slip, lightweight aluminum alloy locking collar *(Patented Design) called the “Grip Lok 30™” is used to anchor the accessories to the top tier of any “X” style stand having 30 mm diameter tubing.
- The QLX/4 mic boom and/or QLX/5 sheet music holder can also be piggy-backed to the QLX/3 second tier.
- To keep pace with the new demands of making music, Quik Lok has also developed the exclusive, versatile LPH/X laptop holder, as well as the IPS/13 universal tablet holder add-on.

QLX/3

- Height, Tilt, Angle & Depth Adjustable Second Tier Add-on
- Five position height adjustment
- Three position angle adjustment
- 7.6” (19.5 cm) depth adjustability range
- QLX/4 Mic boom or QLX/5 music holder can be added, as well as IPS/13 universal tablet holder and LPH/X laptop holder
- 75 lb (33.8 kg) weight capacity

Tier depth:	14.3” - 36 cm
Attaching collar:	Grip-Lok / 30
Weight capacity*:	75 lb - 33.8 kg
Weight:	5.5lb - 2.5 kg
Color:	Black

*(As part of total weight capacity of stand to be used on)

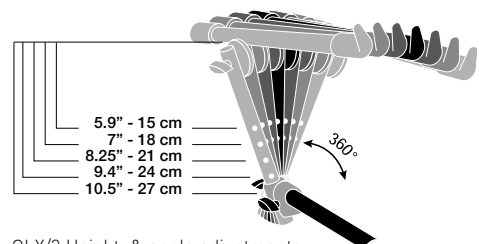

QLX/3 Height, & angle adjustments



QLX/4

- Fully Adjustable Telescopic Mic Boom
- Attaches to the top tier of any “X”-style stand having a 30 mm diameter.

Height positions*:	6.5” to 11.25” 16.5 to 28.5 cm
Attaching collar:	Grip-Lok / 30
Boom length:	22.5” to 40.5” 57 cm to 102 cm
Weight:	2.4 lb - 1.1 kg

*(measured from top of tier to boom swivel)



Keyboard Stands & Accessories



QL/662

- Large Perforated Metal Shelf add-on. Converts any full-sized "X" stand into a convenient table for holding drum machines, multi-track recorders or any kind of non-rack mountable equipment.
- Features reinforced steel bracing for added strength

Side to side width:	28" - 71 cm
Front to back depth:	15.4" - 39 cm
Thickness:	30 mm
Weight:	10lb - 4.7 kg
Weight capacity:	Refer to total weight capacity of stand to be used



QLX/5

- Fully Adjustable Sheet Music Holder
- Attaches to the top tier of any "X"-style stand having a 30 mm diameter.

Height positions*:	6.5" to 11.25" 16.5 to 28.5 cm
Music holder dimensions:	
Width:	17.7" - 45 cm
Height:	12.6" - 32 cm
Bottom lip depth:	2.3" - 6 cm
Attaching collar:	Grip-Lok / 30
Weight:	5.5" - 2.5 kg

*[measured from top of tier to boom swivel]



LPH/X

- Add-on laptop holder for use with X-Series keyboard stands.
- Attaches to the top tier of any "X"-style stand having a 30 mm diameter.
- Can accommodate virtually any size laptop. Four stoppers, adjustable in width and depth, will securely anchor any size laptop, without interfering with input/output ports, expansion slots, cd-rw/dvd drivers, A/C adapter sockets placed on either side of the laptop.
- The laptop tray is height and tilt adjustable, and swivels at 360° to allow for ideal positioning of laptop.
- Equipped with pull-out mouse tray, that can be positioned on either the left or right side of the laptop, and is retractable for easy storage and transport.

Laptop tray dimensions:	10" x 10" 25 x 25 cm
Mouse tray dimensions:	5.3" x 5.3" 13.5 x 13.5 cm
Laptop stoppers width range:	from 10.2" to 16.5" from 26 to 42 cm
Laptop stoppers depth range:	from 10.2" to 16.5" from 26 to 42 cm
Color:	Black



QLY/40 keyboard stand shown with LPH/X optional laptop holder

MS/327

- Headphone holder
- Solid all-metal holder, with soft rubber foam coating on headphone support, to hold it firmly in place, carefully preserving its finish
- By means of its versatile tightening clamp, the MS/327 can be securely anchored to any table top surface, and microphone/sheet music/keyboard/mixer stands of any shape and size ranging from 14 to 48 mm (0.55" to 1.89")

Headphone support width: 3.9" - 10 cm
 Headphone support depth: 1.5" - 4 cm
 Clamp opening: 0.55" to 1.89"
 14 to 48 mm
 Weight: 0.88 lb - 0.40 kg
 Color: Black



IPS/13

- Universal tablet holder
- Clever, safe and practical design allows musicians to integrate their tablet with existing keyboard stands, for use on stage, production studios, in the rehearsal room or at home.
- Will accommodate virtually any size tablet having side measurements ranging from 111 mm to 301 mm (4.37" to 11.85") and depth ranging from 6.9 mm to 18.7 mm (0.27" to 0.73").
- Flexible yet rugged rubberized plastic stoppers will hold the tablet firmly and securely in place, without interfering with dock connector, speaker, headphone jack, on/off and volume buttons.
- No-wobble, lightweight aluminium plate is designed to ensure full tilt and rotational adjustability, and to switch rapidly from the vertical to the horizontal viewing mode without slipping.

- The IPS/13 height-adjustable tablet holder can be fastened directly on to any "X"-style keyboard stand having 30 mm diameter tiers. An innovative, non-slip, lightweight aluminum alloy locking collar called "Grip Lok" is used to anchor the tablet holder to the main tiers or the second tiers of the keyboard stand, or to retrofit it to the QLX/3, WS/422 and Z/727 add-on tiers.

Weight: 2.31 lb - 1.04 kg
 Color: Black



SL/930 keyboard stand shown with IPS/13 optional laptop holder



QUIK-LOK'S "Z" STYLED KEYBOARD STAND SYSTEMS OFFER MUSICIANS TREMENDOUS FLEXIBILITY AND CONVENIENCE

- The "Z" keyboard stand line is a modular system that can be designed in countless ways to suit any users needs
- A single-tier model can eventually be expanded to a fully functionally workstation by adding a variety of available options
- The "Z" frame provides a solid base for supporting all kinds of gear including keyboards/controllers, recording, audio and computer equipment in addition to a large area for placement of floor pedals
- Different models can be configured to perfectly fit stage, studio, home or rehearsal environments
- All stands are constructed with heavy gauge steel and computer-welded joints for years of dependable use

Z/716

- Single-tier, height adjustable "Z" keyboard stand



Tier depth:	19.75" - 50.2 cm
Leg depth:	23.75" - 60.3 cm
Side to side width:	34" - 86.4 cm
Height positions (7):	26.3", 27.5", 28.7", 29.9", 31.1", 32.3", 33.4", 67, 70, 73, 76, 79, 82, 85 cm
Frame tubing size:	30 X 50 mm
Weight capacity:	250 lb - 113 kg
Weight:	17.3 lb - 7.8 kg

Options: Z/720, Z/727, Z/728, Z/729, Z/731, Z/733, ZM/99, Z/735

Z/716L

- Extra-wide, single-tier, height adjustable "Z" keyboard stand



Tier depth:	19.75" - 50.2 cm
Leg depth:	23.75" - 60.3 cm
Side to side width:	44" - 111.8 cm
Height positions (7):	26.3", 27.5", 28.7", 29.9", 31.1", 32.3", 33.4", 67, 70, 73, 76, 79, 82, 85 cm
Frame tubing size:	30 X 50 mm
Weight capacity:	250 lb - 113 kg
Weight:	17.7 lb - 8 kg

Options: Z/720L, Z/727, Z/728, Z/729, Z/731, Z/733, ZM/99, Z/735



Z/726

- Double-tier, height adjustable "Z" keyboard stand with fully adjustable second tier

Main tier depth:	19.75" - 50.2 cm
Second tier depth:	12" - 30.5 cm
Leg depth:	23.75" - 60.3 cm
Side to side width:	34" - 86.4 cm
Height positions (7):	26.3", 27.5", 28.7", 29.9", 31.1", 32.3", 33.4", 67, 70, 73, 76, 79, 82, 85 cm
2 nd tier height positions (4):	9.2", 10.2", 11.2", 12.2" 23.5, 26, 28.5, 31 cm
2 nd tier angles:	90°, 80°, 70°, 60°
Frame tubing size:	30 X 50 mm
Overall Weight capacity:	250 lb - 113 kg
2 nd tier weight capacity:	75 lb - 33.8 kg
Weight:	26.5 lb - 12 kg
Color:	Black

Options: Z/728, Z/731, Z/733, ZM/99, IPS/13, Z/735



Z/726L

- Extra-wide, double-tier, height adjustable "Z" keyboard stand with fully adjustable second tier

Main tier depth:	19.75" - 50.2 cm
Second tier depth:	12" - 30.5 cm
Leg depth:	23.75" - 60.3 cm
Side to side width:	44" - 111.8 cm
Height positions (7):	26.3", 27.5", 28.7", 29.9", 31.1", 32.3", 33.4", 67, 70, 73, 76, 79, 82, 85 cm
2 nd tier height positions (4):	9.2", 10.2", 11.2", 12.2" 23.5, 26, 28.5, 31 cm
2 nd tier angles:	90°, 80°, 70°, 60°
Frame tubing size:	30 X 50 mm
Overall Weight capacity:	250 lb - 113 kg
2 nd tier weight capacity:	75 lb - 33.8 kg
Weight:	27.7 lb - 12.5 kg
Color:	Black

Options: Z/728, Z/729, Z/731, Z/733, ZM/99, Z/735, IPS/13



Keyboard Stands & Accessories



Z/731

- Height Adjustable Utility Shelf
Can be used to hold mini-mixers, drum machines, midi date filers or any other accessories.
- Two Z/731 can be mounted on either side of any "Z" stand and be used as small speaker stands.
- Rubberized cushions firmly hold equipment in place.

Shelf depth:	11.8" - 30 cm
Shelf width:	11.8" - 30 cm
Height adjustment range*:	4.3" to 11.8" 11 to 30 cm
Weight capacity:	40 lb - 18 kg
Weight:	4.8 lb - 2.2 kg

*(from main tier to shelf)

NOTE: Does not require Z/720 or Z/720L accessory bars.



Z/728

- Fully Adjustable Telescopic Mic Boom
- Can be mounted on either side of any "Z" stand

Height adjustability:	15.75" to 26.75" 40 to 68 cm
Boom length range:	22" to 40" 56 to 102 cm
Weight:	3.3 lb - 1.5 kg

NOTE: Does not require Z/720 or Z/720L accessory bars



MS/327

- Headphone holder
- Solid all-metal holder, with soft rubber foam coating on headphone support finish
- The MS327 clamp can be anchored to any table top surface, and microphone/sheet music/keyboard/mixer stands of any shape and size ranging from 14 to 48 mm (0.55" to 1.89")

Headphone support width:	3.9" - 10 cm
Headphone support depth:	1.5" - 4 cm
Clamp opening:	0.55" to 1.89" 14 to 48 mm
Weight:	0.88 lb - 0.40 kg
Color:	Black



Z/735

- Accessory clamp for use with "Z-Style" Keyboard Stands
- Required for connection to stand's top tiers of optional add-ons model QLX/4, QLX/5, LPH/X, IPS/13

Color:	Black
--------	-------

Z/720

- Accessory Bar for Z/716
- The Z/720 is needed to support either the Z/727, Z/729 or Z/733 options
- Standard on Z/726

Width: 30.7" - 78 cm
Weight: 4 lb - 1.8 kg



Z/720L

- Extra-Wide Accessory Bar for Z/716L
- The Z/720L is needed to support either the Z/727, Z/729 or Z/733 options
- Standard on Z/726L

Width: 40.5" - 103 cm
Weight: 4.4 lb - 2 kg



Z/727

- Fully Adjustable Add-On Second Tier
- Tilt, height, depth and width adjustable second tier add-on for use with Z/716 and Z/716L stands.

Tier depth: 12" - 30.5 cm
Height positions (4): 9.2", 10.2", 11.2", 12.2"
23.5, 26, 28.5, 31 cm
Tier angles: 90°, 80°, 70°, 60°
Tier tube size: 30 mm
Weight capacity: 75 lb - 33.8 kg
Weight: 6.6 lb - 3 kg

Options: IPS/13, QLX/3, QLX/4

NOTE: Can be used together with the Z/729 or Z/733 options only on the Z/716L stand



Details of Z/727 new depth adjustable tiers with alignment position markers



Keyboard Stands & Accessories



Z/729

- 3-Page Sheet Music Holder
- Tilt adjustable sheet music holder option for Z/716 or Z/716L stands (requires Z/720 or Z/720L accessory bars)

NOTE: Can be used with the Z/727 or Z/733 options only on the Z/716L and Z/726L stands

Music holder Width:	23.6" - 60 cm
Music holder Height:	11.8" - 30 cm
Music holder Lip depth:	2.3" - 6 cm
Fixed height position*:	7.8" - 20 cm
Weight:	6.2 lb - 2.8 kg

*(from stand tier to tray lip)

Z/716 with Z/720 accessory bar and Z-729 add-on music holder



Z/733

- Add-on laptop holder.
- Also perfect for holding small mixers, rack equipment or remote units.
- Requires Z/720 or Z/720L accessory bars.
- Can accommodate virtually any size laptop. Four stoppers, adjustable in width and depth, will securely anchor any size laptop, without interfering with input/output ports, expansion slots, cd-rw/dvd drivers, A/C adapter sockets placed on either side of the laptop.
- The laptop tray is height and tilt adjustable, and swivels at 360° to allow for ideal positioning of laptop.
- Equipped with pull-out mouse tray, that can be positioned on either the left or right side of laptop.

NOTE: Can be used with the Z/727 or Z/729 options only on the Z/716L and Z/726L stands.

Laptop tray dimensions:	10" x 10" 25 x 25 cm
Mouse tray dimensions:	5.3" x 5.3" 13.5 x 13.5 cm
Laptop stoppers width range:	from 10.2" to 16.5" from 26 to 42 cm
Laptop stoppers depth range:	from 10.2" to 16.5" from 26 to 42 cm
Color:	Black



ZM/99

- "Z" Stand Caster Kit.
- Comes with 2-locking and 2 non-locking casters.
- Fits any Quik-Lok "Z" stand.

Note: Please allow for additional 2.5" (6.3 cm) to the height of stand when using ZM/99 caster kit

Z/71ALU “ULTRALIGHT” ALUMINUM SINGLE-TIER KEYBOARD STRUCTURE

- Quik Lok proudly introduces the new all-aluminum Z/71ALU ULTRALIGHT foldable “Z” structure, patent-pending design that sets up and folds down in literally 10 seconds flat!
- Height adjustment is a snap because of a spring-loaded, dual pin system that instantly releases and locks the tiers into the desired height position.
- This stand is great for tall keyboard players because of Z/71ALU’s maximum height of 39” (99 cm).
- There is absolutely no sacrifice for strength or stability because of this design. In fact, constructed with high-impact aluminum tubing, this is one of the lightest yet sturdiest stands Quik Lok has ever made.
- Some of the other important features of the Z/71ALU:
 - Large area for placement of floor pedals
 - Fully adjustable second tier add-on available, the Z/2ALU. Converts the Z/71ALU to a double-tier stand
 - Compatible with other “Z” series options: Z/728 Mic boom, Z/731 utility shelf and the Z/735 accessory bar that allows for connection of the IPS/13 tablet holder.



Z/71ALU

- ULTRALIGHT aluminum rapid set-up Pro “Z” single-tier keyboard structure



Front to back top tier depth:	16.9” - 43 cm
Front to back bottom leg depth:	20.9” - 53 cm
Side to side width:	34.56” - 87.8 cm
Height positions (13):	from 26” to 39” from 66 to 99 cm
Frame tubing size:	30 x 50 mm
Weight capacity:	250 lb - 113 kg
Weight:	12.66 lb - 5.7 kg
Color:	Black

Options: Z/2ALU, Z/728, Z/731, Z/735

SETS UP AND FOLDS DOWN IN LITERALLY 10 SECONDS ...



Z/2ALU

- Tilt, Height & Depth Adjustable Second Tier Add-on for Z/71ALU
- Rubber-coated tier arms hold keyboards firmly in place
- Securely attaches to main keyboard tier of the Z/71ALU

Tier depth measurement:	12.6” - 32.1 cm
Height positions (4)*:	from 8.6” to 11.8” from 22 to 30 cm
Weight capacity:	75 lb - 33.9 kg
Weight:	4.45 lb - 2 kg
Color:	Black



Z/71ALU keyboard stand complete with Z/2ALU second tier add-on



Keyboard Stands & Accessories

WS/550 LARGE, PORTABLE, HEAVY DUTY, MULTI-FUNCTION STAND

- The WS/550 is one of Quik-Lok's most popular stands because it offers a tremendous amount of flexibility without sacrificing strength
- Ideal for speaker cabinets from 30" to 48" wide (76 to 122 cm), it's also capable of holding the heaviest of keyboards safely and securely.
- Great for large live mixers from 30" to 60" wide (76 to 152 cm), the WS/550 is also perfect for holding DJ coffins, CD rack systems, CD/Record cases and rack cases.
- All four legs are independently height adjustable and each can be swung into position to conform to any keyboard or synthesizer
- Simply swing legs back and the WS/550 folds to a convenient "T" shape for easy transport
- The WS/550 can be expanded to fit your needs by adding any of the available options

WS/550

- Portable, heavy duty, height adjustable stand

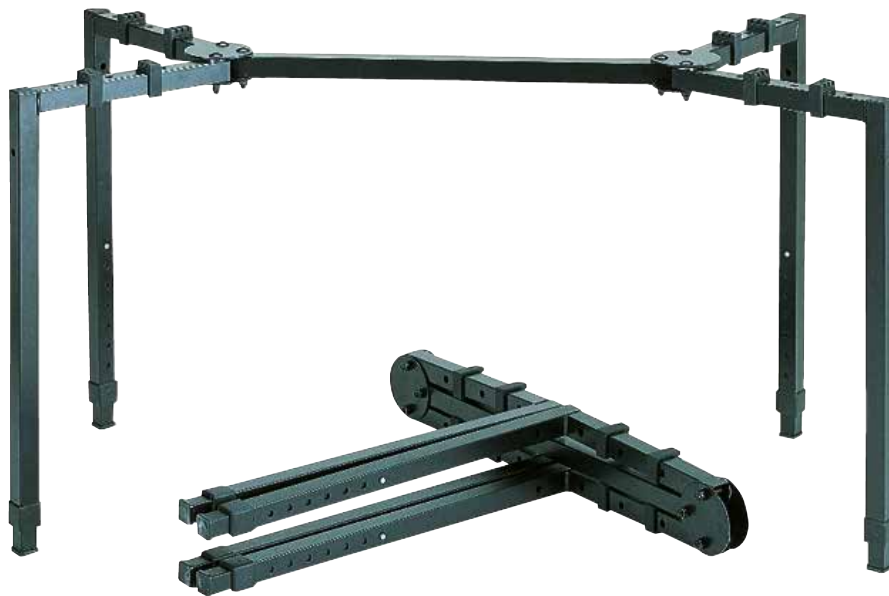

Height positions:	24.25" to 32.5" 61.6 to 81.3 cm
Usable width range:	29.2" to 46.4" 74 to 118 cm
Usable depth range:	17.3" to 27.4" 44 to 69.5 cm
Folded width:	29.2" - 74 cm
Folded height:	24.6" - 62.5 cm
Frame tubing size:	30 mm
Weight Capacity:	250 lb - 113.1 kg
Weight:	18 lb - 8.1 kg
Color:	Black

Options: WS/551, WS/552, WS/561, WS/562, WS/651, Z/727*, Z/729*, Z/733*, QLX/4**, QLX/5**, IPS/13**, LPH/X**

* Note: can be used only in combination with WS/562 crossbar

** Note: can be used only in combination with WS/651 accessory clamp or Z/727 add-on tiers



WS/550 with WS/562 accessory bar and Z/727 add-on tiers

WS/650 LARGE, PORTABLE, HEAVY DUTY MULTI-FUNCTION “T” STAND WITH NEW “QUIK-SET” HEIGHT ADJUSTMENT DEVICE

- The WS/650 is an extremely versatile stand, designed by Quik Lok for countless applications.
- Ideal for speaker cabinets from 30” to 48” wide (76 to 122 cm), it’s also capable of holding the heaviest of keyboards safely and securely.
- Great for large live mixers from 30” to 60” wide (76 to 152 cm), the WS/650 is also perfect for holding DJ coffins, CD rack systems, CD/Record cases and rack cases.
- All four legs are independently height adjustable and each can be swung into position to conform to the size and shape of your equipment.
- Solid rubber rest pads hold speaker equipment firmly in place.
- 8 different height adjustment positions are easily achievable by means of the new Quik Lok height adjustment device with spring-loaded security knob. Just pull the knob and set to the desired height, then release and fasten.
- Tilt-angle adjustments can be made by raising back legs.
- Simply swing legs back and the stand folds down to convenient “T” for easy transport.
- Easily expandable to fit musicians’ needs by adding any of the available QUIK-LOK accessories.

WS/650

- Large, heavy duty multi-function “T” stand

Height positions (8):	24.25” to 32.5” 61.6 to 81.3 cm
Usable width range:	29.2” to 46.4” 74 to 118 cm
Usable depth range:	17.3” to 27.4” 44 to 69.5 cm
Folded width:	29.2” - 74 cm
Folded height:	24.6” - 62.5 cm
Frame tubing size:	30 x 30 mm
Weight Capacity:	250 lb - 113.1 kg
Weight:	18 lb - 8.1 kg
Color:	Black

Options: WS/551, WS/552, WS/561, WS/562, WS/651, Z/727*, Z/729*, Z/733*, QLX/4**, QLX/5**, IPS/13**, LPH/X**

* Note: can be used only in combination with WS/562 crossbar

** Note: can be used only in combination with WS/651 accessory clamp or Z/727 add-on tiers



8 different height adjustment positions are easily achievable by means of the new Quik Lok spring-loaded security knob. Just pull the knob and set to the desired height, then release and fasten.

Keyboard Stands & Accessories

WS/651

- Accessory clamp for use with WS/550, WS/640 & WS/650 multi-function "t" stands

- Required to attach to any one of the four legs of these stand models the following accessories:
 - QLX/4 Telescopic mic boom
 - QLX/5 Sheet music holder
 - IPS/13 Universal tablet holder
 - LPH/X Laptop holder.



WS/640 multi-function stand with WS/651 accessory clamp and LPH/X add-on laptop holder

LPH/X

- Add-on laptop holder for use with X-Series keyboard stands.
- Attaches to the top tier of any "X"-style stand having a 30 mm diameter.
- Can accommodate virtually any size laptop. Four stoppers, adjustable in width and depth, will securely anchor any size laptop, without interfering with input/output ports, expansion slots, cd-rw/dvd drivers, A/C adapter sockets placed on either side of the laptop.
- The laptop tray is height and tilt adjustable, and swivels at 360° to allow for ideal positioning of laptop
- Equipped with pull-out mouse tray, that can be positioned on either the left or right side of the laptop, and is retractable for easy storage and transport.
- Requires WS/651 accessory clamp to attach directly WS/550 and WS/650 keyboard stands

Laptop tray dimensions:	10" x 10" 25 x 25 cm
Mouse tray dimensions:	5.3" x 5.3" 13.5 x 13.5 cm
Laptop stoppers width range:	from 10.2" to 16.5" from 26 to 42 cm
Laptop stoppers depth range:	from 10.2" to 16.5" from 26 to 42 cm
Color:	Black



IPS/13

- Universal tablet holder
- Clever, safe and practical design allows musicians to integrate their tablet with existing keyboard stands, for use on stage, production studios, in the rehearsal room or at home.
- Will accommodate virtually any size tablet having side measurements ranging from 111 mm to 301 mm (4.37" to 11.85") and depth ranging from 6.9 mm to 18.7 mm (0.27" to 0.73").
- Flexible yet rugged rubberized plastic stoppers will hold the tablet firmly and securely in place, without interfering with dock connector, speaker, headphone jack, on/off and volume buttons.
- No-wobble, lightweight aluminium plate is designed to ensure full tilt and rotational adjustability, and to switch rapidly from the vertical to the horizontal viewing mode without slipping.

- The IPS13 height-adjustable tablet holder can be fastened directly on to any "X"-style keyboard stand having 30 mm diameter tiers. An innovative, non-slip, lightweight aluminum alloy locking collar called "Grip Lok" is used to anchor the iPad holder to the main tiers or the second tiers of the keyboard stand, or to retrofit it to the QLX3, WS422 and Z727 add-on tiers.
- Requires WS/651 accessory clamp to attach directly WS/550 and WS/650 keyboard stands

Weight: 2.31 lb - 1.04 kg
Color: Black



QLX/4

- Fully Adjustable Telescopic Mic Boom
- The QLX/4 mic boom can be fastened directly on to any "X"-style keyboard stand having 30 mm diameter tiers. An innovative, non-slip, lightweight aluminum alloy locking collar called "Grip Lok" is used to anchor the mic boom to the main tiers or the second tiers of the keyboard stand, or to retrofit it to the QLX3, WS422 and Z727 add-on tiers.
- Requires WS/651 accessory clamp to attach directly WS/550 and WS/650 keyboard stands

Height positions*: 6.5" to 11.25"
16.5 to 28.5 cm
Attaching collar: Grip-Lok / 30
Boom length: 22.5" to 40.5"
57 cm to 102 cm
Weight: 2.4 lb - 1.1 kg

*(measured from top of tier to boom swivel)



QLX/5

- Fully Adjustable Sheet Music Holder
- The QLX/5 can be fastened directly on to any "X"-style keyboard stand having 30 mm diameter tiers. An innovative, non-slip, lightweight aluminum alloy locking collar called "Grip Lok" is used to anchor the sheet music holder to the main tiers or the second tiers of the keyboard stand, or to retrofit it to the QLX3, WS422 and Z727 add-on tiers.
- Requires WS/651 accessory clamp to attach directly WS/550 and WS/650 keyboard stands

Height positions*: 6.5" to 11.25"
16.5 to 28.5 cm
Music holder dimensions:
Width: 17.7" - 45 cm
Height: 12.6" - 32 cm
Bottom lip depth: 2.3" - 6 cm
Attaching collar: Grip-Lok / 30
Weight: 5.5" - 2.5 kg

*(measured from top of tier to boom swivel)



Keyboard Stands & Accessories

WS/562

Width: 23.8" - 60.5 cm
Weight: 3.3 lb - 1.5 kg

- Accessory Bar for WS/550 and WS650 keyboard stands. Allows use of either the Z/727, Z/733 or Z/729 options.

NOTE: Only one of these options can be used at a time.



WS/650 with WS/562 accessory bar and Z/727 add-on tiers. Two WS/651 accessory clamps are also used to add a QLX/4 mic boom arm to the back leg and a LPH/X laptop holder to the side.



WS/550 stand with WS/562 accessory bar and Z/733 laptop holder

Z/729

- 3-Page Sheet Music Holder
- Tilt adjustable sheet music holder option for WS/550 and WS/650 stands (requires WS/562 accessory bar)

NOTE: Cannot be used with Z/727 or Z/733 options at the same time.

Music holder Width:	23.6" - 60 cm
Music holder Height:	11.8" - 30 cm
Music holder Lip depth:	7.8" - 20 cm
Fixed height position*:	7.8" - 20 cm
Weight:	6.2 lb - 2.8 kg

*(from stand main tier to tilt swivel)



Z/727

- Fully Adjustable Add-On Second Tier
- Tilt, height, depth and width adjustable second tier add-on for WS/550 and WS/650 stands (requires WS/562 accessory bar)

NOTE: Cannot be used together with the Z/729 or Z/733 options at the same time.

Tier depth:	12" - 30.5 cm
Height positions (4):	9.2", 10.2", 11.2", 12.2" 23.5, 26, 28.5, 31 cm
Tier angles:	90°, 80°, 70°, 60°
Weight capacity:	75 lb - 33.8 kg
Weight:	6.6 lb - 3 kg



Details of Z/727 new depth adjustable tiers with alignment position markers



Z/733

- Add-on laptop holder for use with WS/550 and WS/650 stands (requires WS/562 accessory bar).
- Also perfect for small mixers, rack equipment or remote units.
- Four stoppers, adjustable in width and depth, will securely anchor any size laptop, without interfering with input/output ports, expansion slots, cd-rw/dvd drivers, A/C adapter sockets placed on either side of laptop.
- The laptop tray is height and tilt adjustable, and swivels at 360° for ideal positioning of the laptop.
- Equipped with pull-out mouse tray.

NOTE: Cannot be used together with the Z/729 or Z/727 options at the same time.

Laptop tray dimensions:	10" x 10" 25 x 25 cm
Mouse tray dimensions:	5.3" x 5.3" 13.5 x 13.5 cm
Laptop stoppers width range:	from 10.2" to 16.5" from 26 to 42 cm
Laptop stoppers depth range:	from 10.2" to 16.5" from 26 to 42 cm
Color:	Black



Keyboard Stands & Accessories



One of the many workstation systems that can be achieved by adding to the WS/550 base unit (or to the WS/650) any of the available options. The particular configuration here pictured (ordering code WS500) includes WS/550, WS/561, WS/551, WS/552, QL/636, QL/648 and two QF/597



WS/561

- Add-on Vertical Back Spine (incorporating WS/562 accessory bar) for use with WS/550 and WS/650 stands.
- Needed to convert a WS/550 or WS/650 to a modular workstation starter frame for customized configurations
- Add on any of the many options offered for the WS/500 system to customize your own set-up.

Height range:	42" to 49.7" 107 to 126 cm
Width:	27.2" - 69 cm
Weight:	14 lb - 6 kg
Weight capacity:	See weight capacities of individual components.
Color:	Black
Options:	QL/636, QL/648, QF/597, Z/733, Z/727

MS/327

- Headphone holder
- Solid all-metal holder, with soft rubber foam coating on headphone support finish
- The MS327 clamp can be anchored to any table top surface, and microphone/sheet music/keyboard/mixer stands of any shape and size ranging from 14 to 48 mm (0.55" to 1.89")

Headphone support width:	3.9" - 10 cm
Headphone support depth:	1.5" - 4 cm
Clamp opening:	0.55" to 1.89" 14 to 48 mm
Weight:	0.88 lb - 0.40 kg
Color:	Black

WS/551

- Small Utility Shelf
- Solid metal, height adjustable, utility shelf can be used for holding small mixers, drum machines or small multi-track recorders.
- Shelf can be rotated 360 degrees for exact positioning. Easily attaches directly to any leg of WS/550 and WS/650 stands

Shelf dimensions:	
Front to back depth:	11.8" - 30 cm
Side to side width:	11.8" - 30 cm
Height adjustment range*:	0.0" to 8" 0 to 20 cm
Weight capacity:	40 lb - 18 kg
Weight:	4.4 lb - 2 kg

*(from main tier to shelf)



WS/552

- Large Utility Shelf
- Wider version of WS/551 used to accommodate larger equipment

Shelf dimensions:	
Front to back depth:	9.8" - 25 cm
Side to side width:	19.6" - 50 cm
Height adjustment range*:	0.0" to 8" 0 to 20 cm
Weight capacity:	40 lb - 18 kg
Weight:	5.5 lb - 2.5 kg

*(from main tier to shelf)



QL/648

- Small, Fixed-angle, Perforated Metal Shelf
- Attaches to upper slant portion of back spine WS/561.

Side to side width	12" - 30.5 cm
Top to bottom height	8.6" - 22 cm
Bottom lip depth	2" - 5 cm
Weight	2.4 lb - 1.1 kg
Color:	Black



QL/636

- Large Tilt Adjustable Tier
- Attaches to vertical back spine of WS/561.

Side to side width:	17.7" - 45 cm
Front to back usable depth:	13.8 - 35 cm
Usable angle positions:	90°, 81°, 72°, 63°, 54°
Weight capacity:	60 lb - 27.2 kg
Weight:	3.1 lb - 1.4 kg



QF/597

- Fixed-angle perforated metal shelf for attachment to lower portion of vertical back spine WS/561.

Width:	18.5" - 47 cm
Depth:	11.8" - 30 cm
Weight capacity:	50 lb - 22.6 kg
Weight:	4 lb - 1.8 kg



QUIKLOK®

STANDS APART FROM THE REST



www.quiklok.it

STOOLS &
BENCHES



PIANO/ORGAN WOOD BENCHES

PB/010 BK

- Deluxe wood piano bench with manual height-adjustment system
- Comfortable seat cushion in black corduroy
- Constructed of crafted hardwood in gloss black finish

Seat cushion dimensions:

Depth:	12.6" - 32 cm
Width:	22" - 56 cm
Height range:	18.9" to 22.4" 48 to 57 cm
Weight capacity:	245 lb - 110 kg
Weight:	16.4 lb - 7.4 kg
Frame Color:	Glossy Black



Mechanical details of height adjustability device

PB/50 BK S

- Fixed-height wood piano bench
- Comfortable seat cushion in durable black vinyl covering
- Constructed of crafted hardwood in matte black finish

Seat cushion dimensions:

Depth:	12.6" - 32 cm
Width:	22" - 56 cm
Fixed Height:	19.3" - 49 cm
Weight capacity:	245 lb - 110 kg
Weight:	13.1 lb - 5.9 kg
Frame Color:	Matte Black



PB/50 WH S

- Fixed-height wood piano bench
- Comfortable seat cushion in durable white vinyl covering
- Constructed of crafted hardwood in matte white finish

Seat cushion dimensions:

Depth:	12.6" - 32 cm
Width:	22" - 56 cm
Fixed Height:	19.3" - 49 cm
Weight capacity:	245 lb - 110 kg
Weight:	13.1 lb - 5.9 kg
Frame Color:	Matte White

PB/100 BK S

- Deluxe wood piano bench with manual height-adjustment system
- Comfortable seat cushion in durable black vinyl covering
- Constructed of crafted hardwood in matte black finish

Seat cushion dimensions:	
Depth:	12.6" - 32 cm
Width:	22" - 56 cm
Height range:	18.9" to 22.4" 48 to 57 cm
Weight capacity:	245 lb - 110 kg
Weight:	16.4 lb - 7.4 kg
Frame Color:	Matte Black



PB/100 BK L

- Deluxe wood piano bench with manual height-adjustment system
- Comfortable seat cushion in durable black vinyl covering
- Constructed of crafted hardwood in gloss black finish

Seat cushion dimensions:	
Depth:	12.6" - 32 cm
Width:	22" - 56 cm
Height range:	18.9" to 22.4" 48 to 57 cm
Weight capacity:	245 lb - 110 kg
Weight:	16.4 lb - 7.4 kg
Frame Color:	Glossy Black

PB/100 WH S

- Deluxe wood piano bench with manual height-adjustment system
- Comfortable seat cushion in durable white vinyl covering
- Constructed of crafted hardwood in matte white finish

Seat cushion dimensions:	
Depth:	12.6" - 32 cm
Width:	22" - 56 cm
Height range:	18.9" to 22.4" 48 to 57 cm
Weight capacity:	245 lb - 110 kg
Weight:	16.4 lb - 7.4 kg
Frame Color:	Matte White



PB/100 WN S

- Deluxe wood piano bench with manual height-adjustment system
- Comfortable seat cushion in durable black vinyl covering
- Constructed of crafted hardwood in matte walnut finish

Seat cushion dimensions:	
Depth:	12.6" - 32 cm
Width:	22" - 56 cm
Height range:	18.9" to 22.4" 48 to 57 cm
Weight capacity:	245 lb - 110 kg
Weight:	16.4 lb - 7.4 kg
Frame Color:	Matte Walnut



Details of height adjustability device and durable, textured **vinyl** covering found on the PB/100 series wood piano benches

Stools & Benches

BX/8 & BX/9 BUDGET KEYBOARD BENCHES SERIES

- Constructed with 25 mm x 25 mm quality steel tubing
- Computer controlled welded for consistent high quality
- Five height adjustment positions
- Thick, comfortable seat cushion with steel plate reinforcement
- 250 lb (112 Kg) weight capacity
- Durable, textured vinyl covering



BX/8

- Small Bench with Extra Thick Cushion



The BX/8 sets up instantly and folds flat to a compact size for easy storage and transport

Seat cushion dimensions:

Depth:	10" - 25 cm
Width:	21" - 53 cm
Thickness:	3" - 7.5 cm
Height positions (3):	18.8", 20", 22.8" 48, 51, 58 cm
Weight capacity:	250 lbs - 112 kg
Weight:	11.1 lb - 5 kg
Color:	Black

BX/9

- Small Bench with compact seat cushion



The BX/9 sets up instantly and folds flat to a compact size for easy storage and transport

Seat cushion dimensions:

Depth:	10" - 25 cm
Width:	21" - 53 cm
Thickness:	1.6" - 4 cm
Height positions (3):	17.4", 18.6", 21.4" 44.5, 47.5, 54.5 cm
Weight capacity:	250 lbs - 112kg
Weight:	10 lb - 4.5 kg
Color:	Black



BX/14 QUALITY HEIGHT ADJUSTABLE KEYBOARD BENCH

- Constructed with 30 mm x 30 mm quality steel tubing
- Computer controlled welded for consistent high quality
- Five height adjustment positions
- Thick, comfortable seat cushion with steel plate reinforcement
- 250 lb (112 Kg) weight capacity
- Durable, textured vinyl covering

BX/14

- Large Bench with Extra Thick Cushion

Seat cushion dimensions:

Depth:	12" - 30 cm
Width:	24" - 60 cm
Thickness:	3.1" - 8 cm
Height positions (5):	18.3", 21.6", 23.3", 24.3, 25.1" 46.5, 55, 59.5, 62, 64 cm
Leg width positions:	26.4", 21.9", 18.3", 15.3", 13" 67, 55.5, 46.5, 39, 33 cm
Weight capacity:	250 lbs - 112 kg
Weight:	12.2 lb - 5.5 kg
Color:	Black



Sets up instantly and folds flat to a compact size for easy storage and transport



Details of innovative height adjustment system found on the BX/9, BX/8 and BX/14 keyboard benches. Fast, practical and secure locking system with double steel rails and dual snap-in leg design for added safety. Simply slide leg into the two slots found on parallel steel rails and force in to firmly lodge.

Stools & Benches

BX/718 "DELUXE" PORTABLE KEYBOARD BENCH

- Constructed with 30 mm x 30 mm steel tubing and arc-welded joints
- Unique spring-loaded locking pins at base of the seat for safe and secure height adjustments
- Six height positions
- Padded seat cushion reinforced with dual steel rails
- 300 lb (135 kg) weight capacity
- Durable, textured vinyl seat covering



BX/718

- Deluxe Keyboard Bench with Large Extra Thick Seat Cushion

Seat cushion dimensions:	
Depth:	12" - 30 cm
Width:	24" - 60 cm
Thickness:	3.15" - 8 cm
Height positions (6):	17.3", 19.3", 20.9", 22.2", 23.4", 24.4" 44, 49, 53, 56.5, 59.5, 62 cm
Leg width positions (6):	23", 21.6", 20.1", 18.7", 17.3", 15.9" 58.5, 55, 51, 47.5, 44, 40.5 cm
Weight capacity:	300 lbs - 135 kg
Weight:	11.1 lb - 5 kg
Color:	Black



Sets up instantly and folds flat to a compact size for easy storage and transport

QUIK-LOK'S UNIQUE HEIGHT ADJUSTMENT SYSTEM

The BX-718 bench uses a superior, heavy duty, locking system with double steel rails and dual spring-loaded pins on each leg for safe and secure height adjustments. Simply loosen lock screws, pinch together the spring-loaded pins, slide leg to one of four height positions, pins snap into place and then retighten lock screws.



DX/749 HEIGHT ADJUSTABLE MUSICIANS' STOOL

- Perfect for all musicians, including keyboard, guitar, woodwind and brass players, the DX/749 is a special stool designed by Quik Lok to help musicians perform in the ideal ergonomical position and reduce spinal stress and leg strain when playing long sessions, in conditions of maximum stability.
- This stool is fully adjustable, from the soft-foam back rest to the convenient, non-slip footrest, and of course the thick, comfortable, firm, textured seat cushion that can be adjusted in a snap to 11 height positions from 58 to 90 cm (22.8" to 35.4") to suit your playing position perfectly.
- Sturdy steel construction for safe support and years of reliability, this unique musicians seat folds for easy transport and convenient storage.
- The DX/749 features unique design, and ensures supreme comfort and outstanding stability!



DX/749

- Height adjustable musicians stool with adjustable footrest and back rest



Seat cushion dimensions:	
Front to back depth:	12.4" - 31.5 cm
Side to side width:	16.3" - 41.5 cm
Thickness:	60 mm
Height positions (11):	from 22.8" to 35.4" (58 to 90 cm)
Frame width:	15.7" - 40 cm
Frame depth:	18.5" - 47 cm
Fold-up size:	16.1" W x 46.8" H x 15.3" D 41 cm W x 119 H x 39 D
Weight capacity:	242.5 lbs - 110 kg
Weight:	24.4 lb - 11 kg
Color:	Black



Stools & Benches

BZ/7 RAPID MUSICIAN'S SEAT

- New patent-pending design sets up and folds down in 10 seconds
- Perfect complement for the Z/71 keyboard structure or any "Z"-style stand
- Thick, extra-wide seat cushion with textured covering
- Great for guitarists, woodwind and brasswind players, singers or any seated musician applications
- 250 lb (112 kg) weight capacity



BZ/7

- Rapid Set-up Musician's Seat

Seat cushion dimensions:	
Front to back depth:	12.4" - 31.5 cm
Side to side width:	16.3" - 41.5 cm
Thickness:	60 mm
Height positions (7):	from 17.9" to 25" from 45.5 to 63.5 cm
Frame width:	19" - 48.5 cm
Frame depth:	12.8" - 32.5 cm
Weight capacity:	250 lbs - 112 kg
Weight:	18.9 lb - 8.5 kg
Color:	Black

Sets up and folds down in literally 10 seconds...



BX/6 MUSICIAN'S SEAT

- Stable, comfortable stool for all musicians, including drum, keyboard and guitar players
- Sturdy steel construction, the BX/6 features a strong, wiggle-free, foldable 3-leg base
- Multiple height adjustment positions with steel safety pin chain for extra reliability
- Thick, comfortable, foam cushion seat lined with a durable, textured vinyl covering
- Folds for easy transport and storage



BX/6

- Musician's Seat
- Stable, comfortable stool for all musicians, including drum, keyboard and guitar players
- Sturdy steel construction, the BX/6 features a strong, wiggle-free, foldable 3-leg base
- Multiple height adjustment positions with steel safety pin chain for extra reliability
- Thick, comfortable, foam cushion seat lined with a durable, textured vinyl covering
- Folds for easy transport and storage

Seat cushion diameter:	13" - 33 cm
Seat cushion thickness:	70 mm
Height positions (7):	from 23.2" to 31.5" from 59 to 80 cm
Diameter of footprint:	22" - 56 cm
Weight capacity:	230 lbs - 103.5 kg
Weight:	8.9 lb - 4 kg
Color:	Black



Details of leg-joint and height-adjustability clamp designed to ensure maximum safety and amazing stability

DB-SERIES OF PROFESSIONAL DRUMMER'S THRONES

- Perfect for drummers, but also a great option for keyboard and guitar players
- Sturdy, foldable 3-legged metal base with double-brace design and thick rubber feet to ensure ideal floor contact
- Smooth, quick, non-wobbling height adjustability with locking device
- Comfortable, extra thick cushioned seat with durable, high quality vinyl covering



DB/3V

- Chrome-plated drum throne with screw shaft height adjustment
- Comfortable round seat with vinyl covering

Seat cushion diameter:	11.8" - 30 cm
Seat cushion thickness:	65 mm
Height position range:	from 22.4" to 26.4" from 57 to 67 cm
Diameter of footprint:	21.3" - 54 cm
Weight capacity:	250 lbs - 112 kg
Weight:	9.1 lb - 4.1 kg



DB/5V

- Chrome-plated drum throne with screw shaft height adjustment and longer leg braces
- Comfortable extra-thick round seat with vinyl covering

Seat cushion diameter:	11.8" - 30 cm
Seat cushion thickness:	85 mm
Height position range:	from 22" to 24" from 56 to 61 cm
Diameter of footprint:	23.2" - 59 cm
Weight capacity:	250 lbs - 112 kg
Weight:	10 lb - 4.5 kg



DB/9V

- Chrome-plated drum throne with screw shaft height adjustment and longer leg braces
- Saddle style seat cushion with premium foam padding for extra comfort

Seat cushion thickness:	85 mm
Height position range:	from 22" to 25.6" from 56 to 65 cm
Diameter of footprint:	20.5" - 52 cm
Weight capacity:	250 lbs - 112 kg
Weight:	13.3 lb - 6 kg



DB/S

- Optional back rest for use with DB/9V drum throne



MICROPHONE
STANDS & ACCESSORIES



Microphone Stands & Accessories

300 SERIES "MICROLITE" MICROPHONE STANDS

- Constructed with strong, lightweight "Microlite" tubular steel
- Fast, smooth, non-slip boom swivel and height adjustments
- Available in scratch-resistant, baked-on, non-reflective, black enamel finish
- Legs on tripod models bounce back into place if stepped on
- All locking points are protected by scratch-proof contact points
- Convenient mic cable clips supplied with every stand
- All parts are replaceable
- Five-year limited warranty

A/300

- Straight, Tripod with Fixed Length Boom

Height adjustment range:	37.75" to 62" 95.9 to 157.5 cm
Boom length:	30" - 76.2 cm
Diameter of leg spread:	27.25" - 69.2 cm
Folded height:	38" - 96.5 cm
Weight:	4.2 lb - 1.9 kg
Color:	Black

A/344

- Straight, Tripod

Height adjustment range:	37.25" to 62.5" 94.6 to 158.8 cm
Diameter of leg spread:	27.25" - 69.2 cm
Folded height:	32.3" - 82 cm
Weight:	3.3 lb - 1.5 kg
Color:	Black

A/340

- Short, Tripod with Fixed Length Boom

Height adjustment range:	20.5" to 30.25" 52.1 to 76.8 cm
Boom length:	30" - 76.2 cm
Diameter of leg spread:	21.3" - 54 cm
Folded height:	29.9" - 76 cm
Weight:	3.1 lb - 1.4 kg
Color:	Black

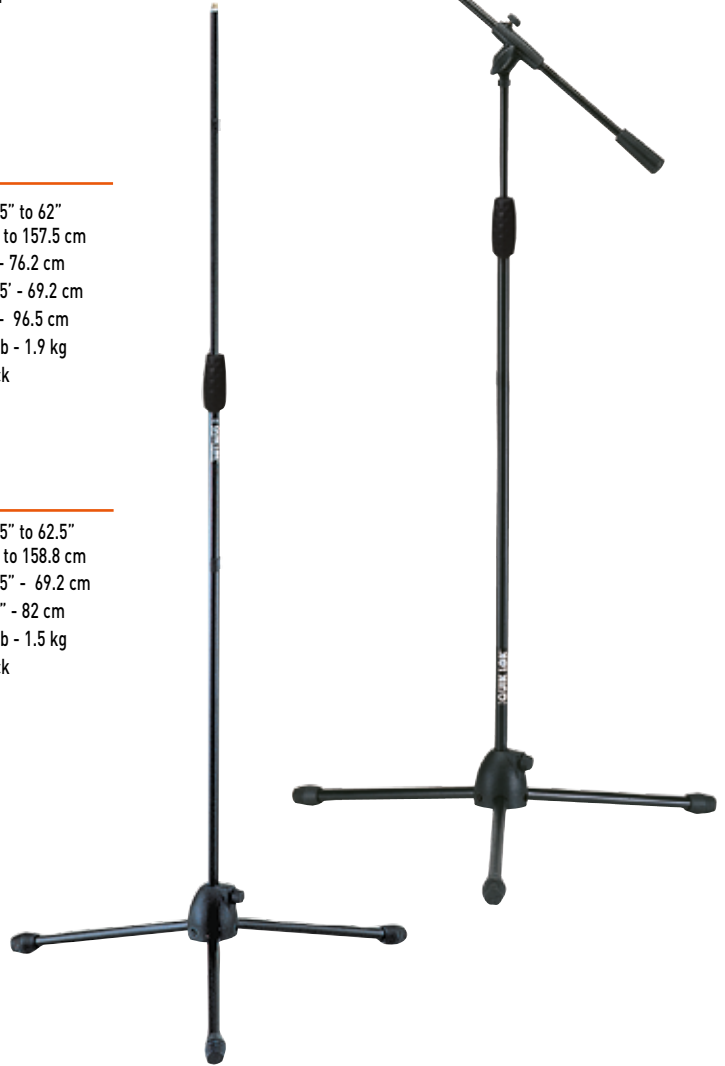

A/346

- Straight, Tripod with Telescopic Boom

Height adjustment range:	37.75" to 62" 95.9 to 157.5 cm
Boom length:	22" to 40" 55.9 to 101.6 cm
Diameter of leg spread:	27.25" - 69.2 cm
Folded height:	38" - 96.5 cm
Weight:	4.2 lb - 1.9 kg
Color:	Black



New improved telescopic boom design with new telescopic block clamp to ensure smooth adjustments and a secure grip.



Fast, easy height adjustments are possible by means of the new clutch unit.



Convenient mic cable clips supplied with every stand



Fast, smooth, non-slip boom swivel and height adjustments. All locking points are protected by scratch-proof contact points



New Improved Tripod Leg Base Design The polycarbonate leg base found on the 300 series tripod stands use a new block clamp system that locks the base securely when tightened.



High impact-resistant lightweight polycarbonate base with tubular steel tripod legs. Step on a leg, and it will bounce back in place.



A/341

- Short, Tripod with Telescopic Boom

Height adjustment range:	16.5" to 19.25" 41.9 to 48.9 cm
Boom length:	22" to 40" 55.9 to 101.6 cm
Diameter of leg spread:	21.3" - 54 cm
Folded height:	22.4" - 57 cm
Weight:	3.1 lb - 1.4 kg
Color:	Black

Microphone Stands & Accessories

“IN-SYNC” TRIPOD BASE MICROPHONE BOOM STANDS

- Constructed with strong, lightweight “Microlite” tubular steel.
- New boom swivel made of ABS composite material for high impact resistance ensures fast, smooth, non-slip angle and height adjustments.
- Boom swivel clamp is ergonomically designed for ease of use and allows to adjust the boom length and angle at the same time, with one move only. Perfect integration of style and functionality!
- Fast, easy and secure height adjustments are possible by means of the stylish, soft-grip, ergonomical clutch unit.
- All locking points are protected by scratch-proof contact points.
- Newly designed tripod leg base incorporating a truly innovative, advanced-technology locking system that allows to open and close this stand in a flash. Just raise the “release” leg to a slightly angled position to set the base free to move. Then lift the leg to its full extent and the base will firmly lock in position, to ensure maximum stability and reliability. No knobs to tighten or lose!!
- Strong, impact-resistant, lightweight polycarbonate base with tubular steel tripod legs. Step on a leg, and it will bounce back in place!
- Convenient mic cable management clips supplied with every stand.
- Available in scratch-resistant, baked-on, non-reflective, black enamel finish.

A/302

- Straight, tripod with fixed length boom

Height adjustment range:	38.2" to 64.2" 97 to 163 cm
Boom length:	30.3" - 77 cm
Diameter of leg spread:	28.3" - 72 cm
Folded height:	36.2" - 92 cm
Weight:	4.44 lb - 2 kg
Color:	Black



Newly designed tripod leg base incorporating a truly innovative, advanced-technology locking system that allows to open and close this stand in a flash. Just raise the “release” leg to a slightly angled position to set the base free to move. Then lift the leg to its full extent and the base will firmly lock in position, to ensure maximum stability and reliability. No knobs to tighten or lose!!

A/305

- Short, Tripod with Fixed Length Boom

Height adjustment range:	20.5" to 30.25" 52.1 to 76.8 cm
Boom length:	30" - 76.2 cm
Diameter of leg spread:	21.3" - 54 cm
Folded height:	29.9" - 76 cm
Weight:	3.88 lb - 1.75 kg
Color:	Black

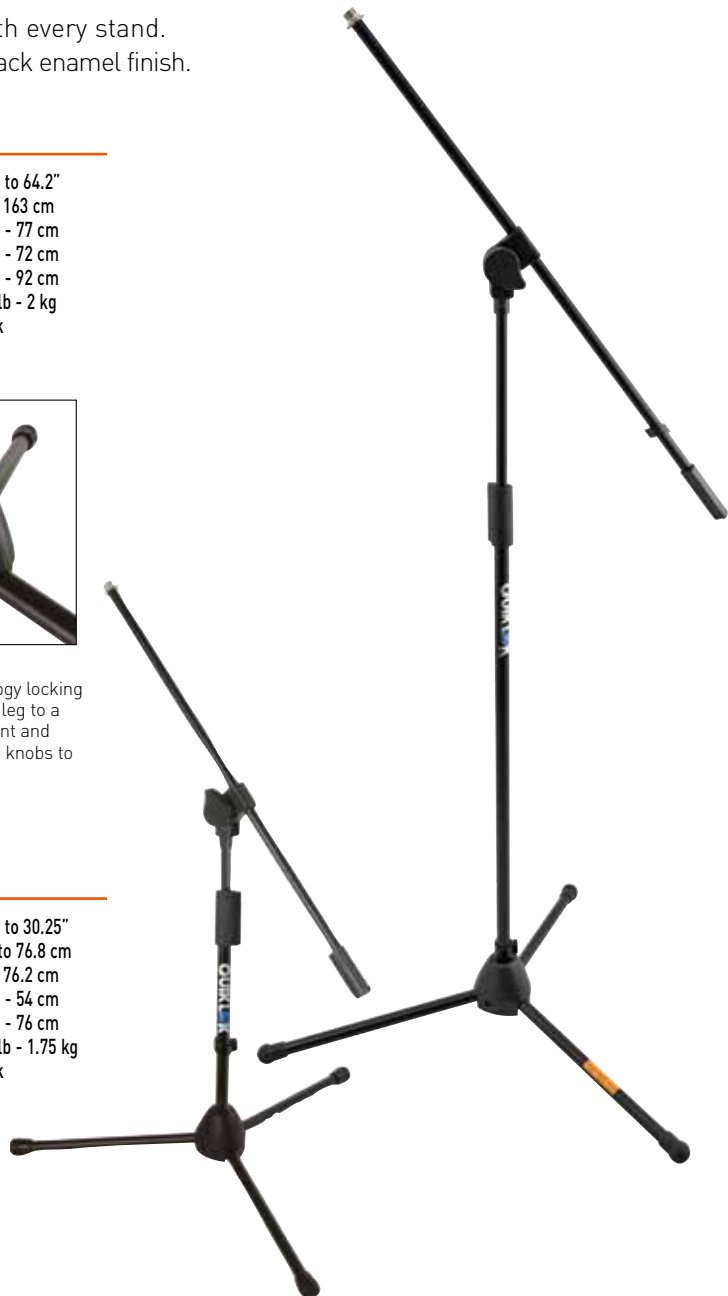



A/304

- Straight, Tripod with Telescopic Boom

Height adjustment range:	37.75" to 62" 95.9 to 157.5 cm
Boom length:	22" to 40" 55.9 to 101.6 cm
Diameter of leg spread:	27.25" - 69.2 cm
Folded height:	38" - 96.5 cm
Weight:	4.44 lb - 2 kg
Color:	Black



New boom swivel made of ABS composite material for high impact resistance ensures fast, smooth, nonslip angle and height adjustments. Boom swivel clamp is ergonomically designed for ease of use and allows to adjust the boom length and angle at the same time, with one move only. Perfect integration of style and functionality!



Fast, easy and secure height adjustments are possible by means of the elegant, soft-grip, ergonomical clutch unit.



Stylish boom end piece matches contemporary design of height adjustment clutch. Convenient mic cable clips supplied with every stand.



Strong, impact-resistant, lightweight polycarbonate base with tubular steel tripod legs. Step on a leg, and it will bounce back in place.



New improved telescopic boom design with new lever-style block clamp to ensure smooth adjustments and a secure grip.

A/306

- Short, Tripod with Telescopic Boom

Height adjustment range:	16.5" to 19.25" 41.9 to 48.9 cm
Boom length:	22" to 40" 55.9 to 101.6 cm
Diameter of leg spread:	21.3" - 54 cm
Folded height:	22.4" - 57 cm
Weight:	3.88 lb - 1.75 kg
Color:	Black

Microphone Stands & Accessories

A/302PACK-2

- Microphone & Mic Stand Kit

The Quiklok Mic Stand Package includes:

A302 Microphone Boom Stand

Height adjustment range: 38.2" to 64.2"
97 to 163 cm
Boom length: 30.3" - 77 cm
Diameter of leg spread: 28.3" - 72 cm
Folded height: 36.2" - 92 cm
Weight: 4.44 lb - 2 kg
Color: Black

QMD043 Dynamic Microphone

Element: Moving Coil Dynamic
Polar Pattern: Uni-directional
Frequency Response: 60Hz-15KHz
Sensitivity: -54dB±3dB
(0dB=1V/Pa at 1KHz)
Output Impedance: 600 Ohm±30%

Microphone Cable

with male XLR to female XLR connectors (5mt - 17' length)

MP890 Slip-in Rubber Mic Clamp

Nylon Tote Bag



A/399



A/399

- Straight, round base Mic Stand with heavy-duty cast-iron base.
- Full-circumference rubber gasket on base to prevent scratching floor surfaces, and allow for excellent stability

Height adjustment range: 35.5" to 61.5"
90.2 to 156.2 cm
Base Diameter: 9.75" - 24.75 cm
Folded height: 35.5" - 90.2 cm
Weight: 7.8 lb - 3.5 kg
Color: Black

A/386

- Add-on telescopic boom with steel boom swivel

Boom length: 22" to 40"
55.9 to 101.6 cm
Weight: 1.2 lb - 0.54 Kg
Color: Black



A/302PACK-1

- Microphone Stand and Cable Kit

The Quiklok Mic Stand Package includes:

Three A302 Microphone Boom Stands
 Height adjustment range: 38.2" to 64.2"
 97 to 163 cm
 Boom length: 30.3" - 77 cm
 Diameter of leg spread: 28.3" - 72 cm
 Folded height: 36.2" - 92 cm
 Weight: 4.44 lb - 2 kg
 Color: Black

Three Microphone Cable
 with male XLR to female XLR connectors
 (5mt - 17' length)

Nylon Tote Bag

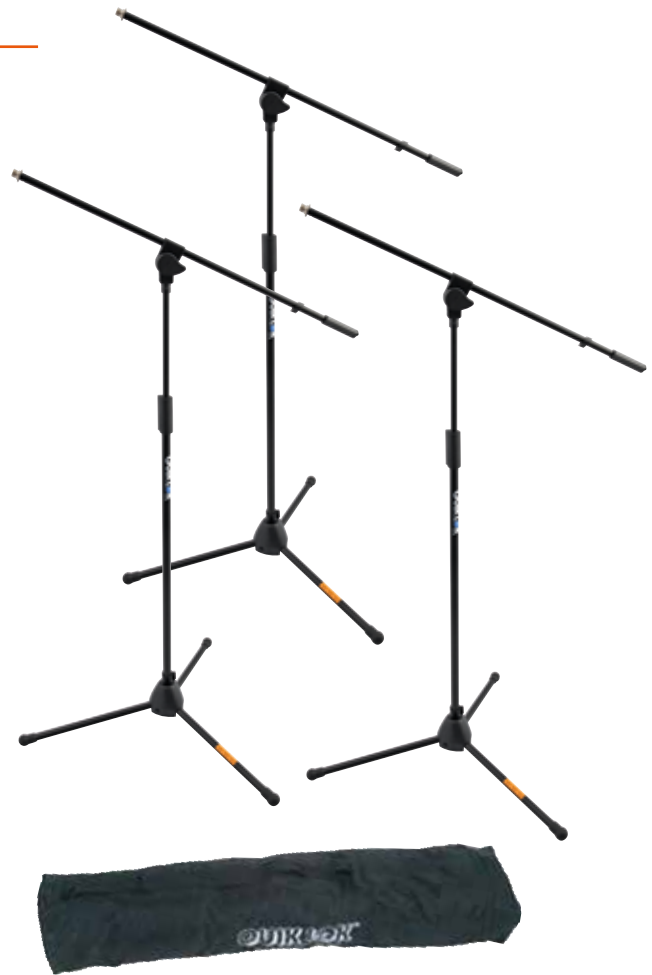
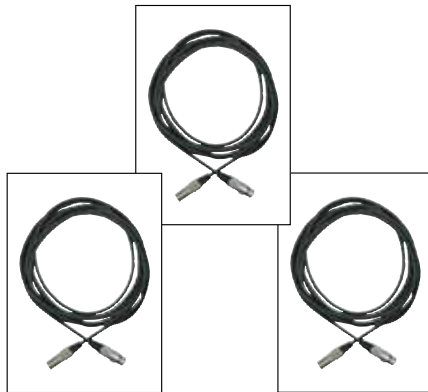

A/495

- Short microphone stand with telescopic mic boom and metal boom swivel. Featuring heavy-duty cast-iron round base with full-circumference rubber gasket to prevent scratching floor surfaces and provide excellent stability.

Height adjustment range: 15" to 22.83"
 38 to 58 cm
 Boom length: 20.8" to 35.8"
 53 to 91 cm
 Base diameter: 9.75" - 24.75 cm
 Folded height: 21.6" - 55 cm
 Weight: 7.8 lb - 3.5 kg
 Color: Black

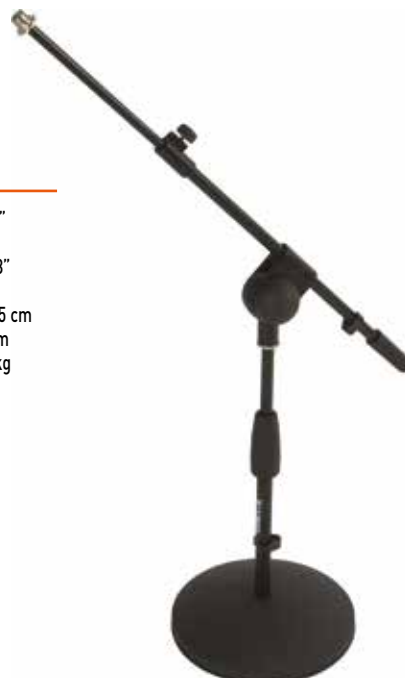

Microphone Stands & Accessories

400 SERIES "PERFORMER" MICROPHONE STANDS

- Manufactured using heavy duty steel tubing and high-grade hardware
- Cast-alloy tripod leg base design, incorporating a new block clamp system, to ensure maximum stability and reliability as demanded by the professional musicians
- All-metal boom swivel ensures fast, smooth, non-slip angle and height adjustments
- Available in scratch-resistant, baked-on, non-reflective, black enamel finish
- All locking points are protected by scratch-proof contact points
- Convenient mic cable clips supplied with every stand
- All parts are replaceable
- Five-year limited warranty



A/492

- Microphone stand featuring cast-alloy tripod base and fixed length mic boom with metal boom swivel.

Height adjustment range:	39.3" to 69.3" 100 to 176 cm
Boom length:	31.5" - 80 cm
Diameter of leg spread:	27.5" - 69.9 cm
Folded height:	37.5" - 95.3 cm
Weight:	5.45 lb - 2.45 kg
Color:	Black



All-metal boom swivel ensures fast, smooth, non-slip angle and height adjustments



Cast-alloy tripod leg base design, incorporating a new block clamp system that locks the base securely when tightened



Stylish boom end piece matching same contemporary design of height adjustment clutch and boom swivel knob

A/494

- Microphone stand featuring cast-alloy tripod base and telescopic mic boom with metal boom swivel.

Height adjustment range:	39.3" to 69.3" 100 to 176 cm
Boom length:	20.8" to 35.8" 53 to 91 cm
Diameter of leg spread:	27.5" - 69.9 cm
Folded height:	37.5" - 95.3 cm
Weight:	5.8 lb - 2.6 kg
Color:	Black



Fast, easy height adjustments are possible by means of the new clutch unit.



Convenient mic cable clips supplied with every stand



A/496

- Short microphone stand featuring cast-alloy tripod base and telescopic mic boom with metal boom swivel.

Height adjustment range:	20.5" to 30.25" 52.1 to 76.8 cm
Boom length:	20.8" to 35.8" 53 to 91 cm
Diameter of leg spread:	21.3" - 54 cm
Folded height:	29.9" - 76 cm
Weight:	4.6 lb - 2.1 kg
Color:	Black



Microphone Stands & Accessories

500 SERIES PROFESSIONAL MICROPHONE STANDS

- Manufactured using heavy duty steel tubing and high-grade hardware
- Newly designed cast-alloy tripod leg base, incorporating an innovative locking system, that increases the clamping surface, ensuring maximum stability and reliability, as demanded by professional musicians
- Modern, contemporary all-metal boom swivel ensures fast, smooth, non-slip angle and height adjustments
- Knobs on boom swivel are ergonomically designed for ease of use and built to prevent them from falling off the stand when loose or completely unscrewed
- All locking points are protected by scratch-proof contact points
- Fast, easy and secure height adjustments are possible by means of the stylish, ergonomic clutch unit
- Convenient mic cable clips supplied with every stand
- All parts are replaceable
- Available in scratch-resistant, baked-on, non-reflective, black enamel finish
- Five-year limited warranty



A/512

- Professional microphone stand featuring heavy-duty cast-alloy tripod base and fixed length mic boom with metal boom swivel

Height adjustment range:	39.3" to 69.3" 100 to 176 cm
Boom length:	31.5" - 80 cm
Diameter of leg spread:	27.5" - 69.9 cm
Folded height:	37.5" - 95.3 cm
Weight:	8.22 lb - 3.7 kg
Color:	Black



Modern and contemporary all-metal boom swivel ensures fast, smooth, non-slip angle and height adjustments. Knobs on boom swivel are ergonomically designed for ease of use and built to prevent them from falling off the stand when loose or completely unscrewed



Newly designed cast-alloy tripod leg base, incorporating an innovative locking system, that increases the clamping surface, ensuring maximum stability and reliability, as demanded by professional musicians

A/514

- Professional microphone stand featuring heavy-duty cast-alloy tripod base and telescopic mic boom with metal boom swivel

Height adjustment range:	39.3" to 69.3" 100 to 176 cm
Boom length:	20.8" to 35.8" 53 to 91 cm
Diameter of leg spread:	27.5" - 69.9 cm
Folded height:	37.5" - 95.3 cm
Weight:	8.55 lb - 3.85 kg
Color:	Black



Fast, easy and secure height adjustments are possible by means of the stylish, ergonomic clutch unit



Stylish boom end piece matches elegant design of height adjustment clutch



Convenient mic cable clips supplied with every stand



Equipped with user-friendly and easily maneuverable mic holder stopper



A/516

- Short professional microphone stand featuring heavy-duty cast-alloy tripod base and telescopic mic boom with metal boom swivel

Height adjustment range:	20.5" to 30.25" 52.1 to 76.8 cm
Boom length:	20.8" to 35.8" 53 to 91 cm
Diameter of leg spread:	21.3" - 54 cm
Folded height:	29.9" - 76 cm
Weight:	8.22 lb - 3.7 kg
Color:	Black

Microphone Stands & Accessories

900 SERIES MICROPHONE STANDS WITH ONE-HAND CLUTCH HEIGHT ADJUSTMENT MECHANISM

- Fast, smooth, non-slip height adjustments with the press of the hand.
- Constructed with strong, lightweight "Microlite" tubular steel.
- Scratch-resistant, baked-on black enamel finish.
- The A/988 features a heavy-duty cast-iron round base that will not chip or scratch.
- The A/987 is built using a lightweight but sturdy polycarbonate tripod leg base design.
- The A/989 tripod leg base stand features a telescopic boom.



A/988

- Straight, cast-iron round base mic stand with one-hand clutch height adjustment mechanism
- Featuring heavy-duty cast-iron round base with full-circumference rubber gasket to prevent scratching floor surfaces and provide excellent stability

Height adjustment range:	40.9" to 61.6" 104 to 156.6 cm
Diameter of base:	9.75" - 24.8 cm
Folded height:	40.9" - 104 cm
Weight:	10.6 lb - 4.8 kg
Color:	Black



A/989

- Tripod leg base mic stand with telescopic boom and one-hand clutch height adjustment mechanism

Height adjustment range:	40.9" to 61.6" 104 to 156.6 cm
Boom length:	22" to 40" 55.9 to 101.6 cm
Diameter of leg spread:	27.25" - 69.2 cm
Folded height:	40.9" - 104 cm
Weight:	4.6 lb - 2.1 kg
Color:	Black

A/987

- Straight, tripod leg base mic stand with one-hand clutch height adjustment mechanism

Height adjustment range:	40.9" to 61.6" 104 to 156.6 cm
Diameter of leg spread:	27.25" - 69.2 cm
Folded height:	40.9" - 104 cm
Weight:	4 lb - 1.8 kg
Color:	Black



Microphone Stands & Accessories

A/50 HEIGHT ADJUSTABLE TRIPOD STUDIO BOOM STAND WITH CASTERS

- Perfect stand for any recording, broadcast or live show application
- Tripod leg design with dual bracing is built using SOLID STEEL LEGS - not tubing - to provide stable base for use with all kinds of studio mics
- Easy-roll locking casters secure the stand firmly in place
- Folds down to compact size for easy transport
- Telescopic, 87" (221 cm) boom with adjustable counter weight for precise balancing
- Supplied with convenient mic cable clips
- Available in scratch-resistant, baked-on, non-reflective black enamel finish

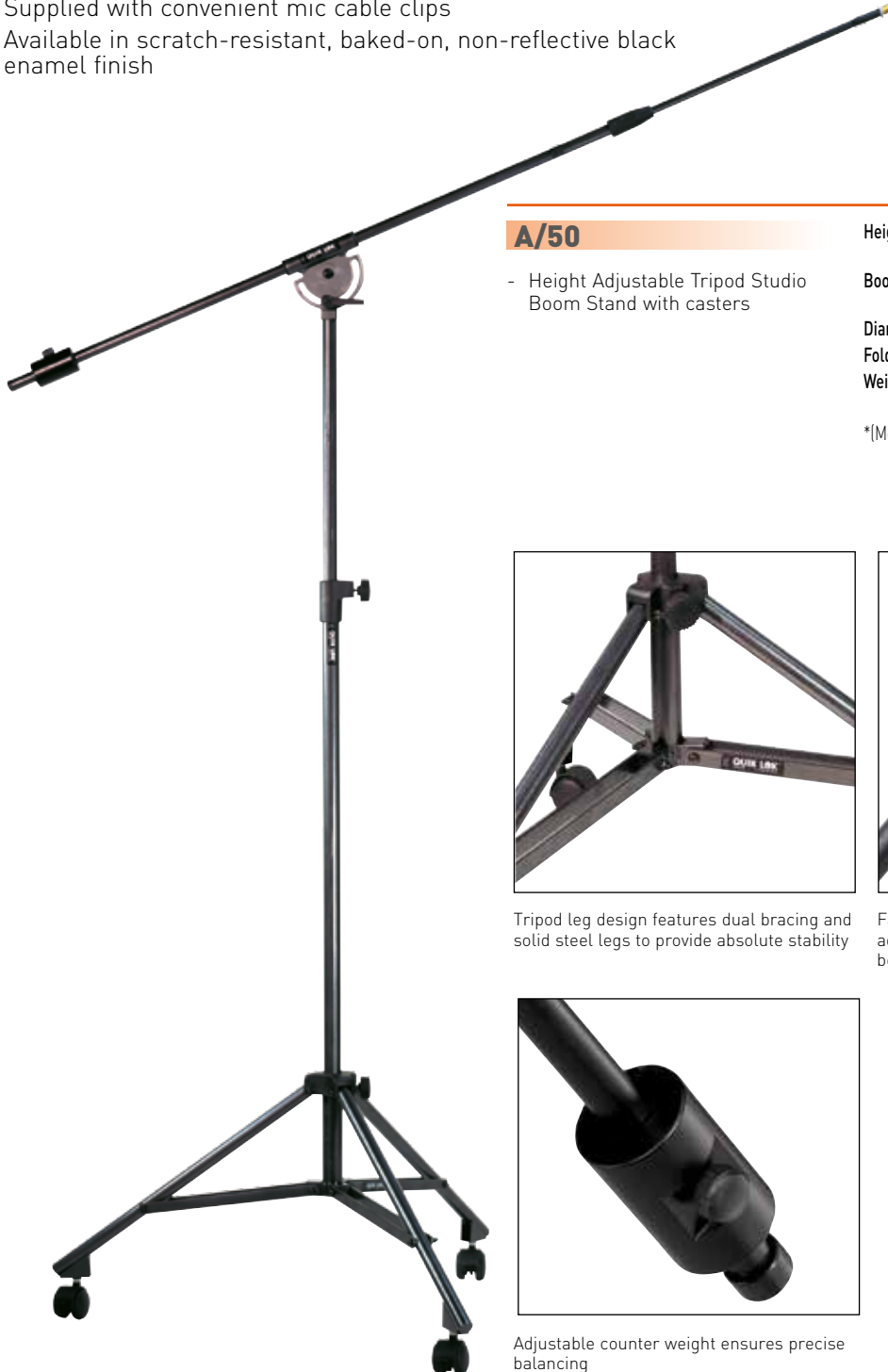

A/50

- Height Adjustable Tripod Studio Boom Stand with casters

Height adjustment range*:	53.5" to 91.5" 136 to 232.5 cm
Boom length:	46.5" to 87" 118 to 221 cm
Diameter of leg spread:	36" - 91.4 cm
Folded height:	53.8" - 136.7 cm
Weight:	30 lb - 13.5 kg

*(Measured from floor to boom swivel)



Tripod leg design features dual bracing and solid steel legs to provide absolute stability



Fast, smooth, safe, non-slip boom adjustments are ensured by all-steel boom swivel



Adjustable counter weight ensures precise balancing

A/85 HEIGHT ADJUSTABLE TRIPOD STUDIO BOOM STAND

- Perfect stand for any recording or project studio
- Tripod leg design provides steady, stable base for holding all kinds of studio microphones
- Non-strip-out height adjustment and leg joint collar hardware with block tightening clamp assembly
- Manufactured using lightweight steel tubing
- Folds down to compact size for easy transport
- Telescopic, 76" (194 cm) boom with adjustable counter weight for precise balancing
- Supplied with convenient mic cable clips
- Quality construction at a low price



A/85

- Height Adjustable Tripod Studio Boom Stand



Folds down to compact size (55.1" - 140 cm) for easy transport

Height adjustment range*:	59" to 93" 150 cm to 236 cm
Boom length:	44.9" to 76.4" 114 cm to 194 cm
Diameter of leg spread:	39.4" - 100 cm
Folded height:	55.1" - 140 cm
Weight:	15.9 lb - 7.15 kg
Color:	Black

*(measured from top of boom swivel to floor)



Boom adjustments are made easily by simply loosening the center knob and moving to anyone of the infinite, non-slip angle adjustment positions



Adjustable counter weight ensures precise balancing.

Microphone Stands & Accessories

A/156 CLAMP-ON MICROPHONE BOOM ARM FOR ACOUSTIC GRAND PIANOS

- Truly innovative (patent-pending) and unique microphone boom arm designed to mic any grand piano in the most ideal way, so as to preserve and emphasize its acoustic characteristics, avoiding the congestion of several floor microphone stands all around the piano.
- Can be easily and securely anchored to any grand piano lid or case. Heavy, metal tightening clamp with soft rubber foam pads to aptly protect the lacquer finish of piano lid and case, and prevent from scratches and stains.
- By far the best solution for optimal positioning of up to two microphones into a grand piano body, for both live performances on stage and studio recording sessions.
- All-metal boom swivel ensures fast, smooth, non-slip angle and length adjustments.
- Extremely versatile, the A/156 can as well be used as a microphone desk arm for studios and workstations.

A/156

- Clamp-on telescopic microphone boom arm for acoustic grand pianos

Telescopic boom length:	14.56" to 30" 37 to 75.5 cm
Clamp opening:	0.8" to 12.4" 2.05 to 3.15 cm
Clamp length:	8.26" - 21 cm
Weight:	4.3 lb - 1.94 kg
Color:	Black



Shown above, the A/156 mic boom arm anchored to the piano body with MP/900 dual mic holder, and, on the right, pictured anchored to the piano lid. Microphones are positioned within the piano body to achieve a more direct and higher-definition sound pickup.



IPS/12 UNIVERSAL TABLET HOLDER

- Clever, safe and practical design allows musicians to integrate their tablet with existing microphone and sheet music stands, for use on stage, production studios, in the rehearsal room or at home.
- Will accommodate virtually any size tablet having side measurements ranging from 111 mm to 301 mm (4.37" to 11.85") and depth ranging from 6.9 mm to 18.7 mm (0.27" to 0.73").
- Flexible yet rugged rubberized plastic stoppers will hold the tablet firmly and securely in place, without interfering with dock connector, speaker, headphone jack, on/off and volume buttons.
- No-wobble, lightweight aluminium plate is designed to ensure full tilt and rotational adjustability, and to switch rapidly from the vertical to the horizontal viewing mode without slipping, for ideal positioning of your tablet.
- The holder can be fastened directly on to any 3/8" standard microphone stand thread connection. A slim yet sturdy steel bracket (included) allows to mount the tablet holder sideways to the vertical pole of any microphone or sheet music stand with diameter ranging from 14 to 30 mm (0.55" to 11.8").

IPS/12

Weight: 0.66 kg (1.47 lb)
Color: Black

- Universal tablet holder
- Will accommodate virtually any size tablet having side measurements ranging from 111 mm to 301 mm (4.37" to 11.85") and depth ranging from 6.9 mm to 18.7 mm (0.27" to 0.73").



Microphone Stands & Accessories



A/25

- Microphone Desk Arm for studios and multi-media workstations.
- Can be securely anchored to any table top surface by means of its tightening clamp (adjustable up to 50 mm), or its screw-on table flange.
- The flexible yet steady microphone desk arm comes with mic threaded adaptor and includes a microphone cable.

Max load capacity: 1.7 lb - 0.8 kg
Color: Black



A/188

- Desk tripod microphone stand with rubber mic holder

Height adjustment range: 4.3" to 6.7" / 11 to 17 cm
Diameter of base: 7.5" - 19 cm
Weight: 0.75 lb - 335 g
Color: Black



A/114

- Short, Height Adjustable with Cast-Iron Triangle Base
- Height adjustable with tiltable, swiveling mast
- Available in either black enamel or chrome plated finishes
- Can be used on floor or table top for micing drums, amps or conference rooms.

Front width: 5.9" - 15 cm
Back width: 2.4" - 6 cm
Depth: 7.5" - 19 cm
Height: 1.3" - 3.3 cm
Room adjustment range: 13.7" to 22.4" / 35 to 57 cm
Weight: 5.5 lb - 2.5 kg
Color: Black or Chrome



MS/303

- Small Clamp-on Sheet Music Holder
- Heavy, thick metal clamp securely attaches to mast of almost any standard mic stand

Sheet Music holder dimensions
Height: 7.9" - 20 cm
Width: 11.75" - 30 cm
Bottom lip: 2.3" - 6 cm
Clamp opening: 0.55" to 1.18" / 14 to 30 mm
Weight: 2.1 lb - 0.95 kg
Color: Black

A/107

- Clamp-on Boom Arm Attachment
- Add extra microphones without more stands congestions
- Perfect for micing saxophones, drums, acoustic guitars, etc.
- Rubber-tipped 8 mm lock screw will not strip-out when tightened or scratch mic stand
- Heavy, thick metal clamp securely attaches to mast of any standard mic stand

Boom length: 30" - 76.2 cm
 Vertical pole height: 10" - 25.4 cm
 Clamp opening: 0.55" to 1.18"
 14 to 30 mm
 Weight: 1.6 lb - 0.72 kg
 Color: Black



MS/326

- Clamp-on beverage holder
- Solid metal holder for bottles, glasses, cans and cups with maximum diameter of 84 mm.
- Heavy, thick metal clamp securely attaches to microphone and sheet music stands with tubing diameter of up to 30 mm.
- Ideal performance companion, keeps your drink at immediate reach when needed!

Height: 18.2" - 8.2 cm
 Diameter: 3.34" - 8.5 cm
 Clamp opening: 0.55" to 1.18"
 14 to 30 mm
 Weight: 0.81 lb - 0.366 kg
 Color: Black



MS/327

- Headphone holder
- Clever, safe and practical headphone holder allows musicians to keep their headphone within immediate reach when not in use, hanging it on any instrument stand or multi-media workstation, for use on stage, production studios, in the rehearsal room or at home
- Solid all-metal holder, with soft rubber foam coating on headphone support, to hold it firmly in place, carefully preserving its finish
- By means of its versatile tightening clamp, the MS327 can be securely anchored to any table top surface, and microphone/sheet music/keyboard/mixer stands of any shape and size ranging from 14 to 48 mm (0.55" to 1.89")

Headphone support width: 3.9" - 10 cm
 Headphone support depth: 1.5" - 4 cm
 Clamp opening: 0.55" to 1.89"
 14 to 48 mm
 Weight: 0.88 lb - 0.40 kg
 Color: Black



MS/329

- Large Clamp-on Utility Tray
- Designed to keep small devices and utilities within immediate reach while performing

Tray dimensions:
 Depth: 8.4" - 21.3 cm
 Width: 8.4" - 21.3 cm
 Clamp opening: 0.55" to 1.18"
 14 to 30 mm
 Weight: 2.6 lb - 1.2 kg
 Color: Black



Microphone Stands & Accessories

FAP/01

- Professional Pop Filter designed with moulded plastic filter
- Easily connects to any microphone stand to prevent annoying vocal thrusts.



FAP/05

- Professional Pop Filter designed with finer nylon filter
- Easily connects to any microphone stand to prevent annoying vocal thrusts.



MP/840

- Flexible plastic tapered mic holder



MP/850

- Spring-Loaded Plastic Mic Clip for Wired and Wireless Microphones



MP/892

- Small Rubber Mic Clip for Wired Microphones



MP/890

- Large Rubber Mic Clip for Wireless Microphones



MP/891

- Shock-proof mic holder
- Isolates microphone from stand and stage vibrations.



MP/900

- Adjustable dual microphone holder

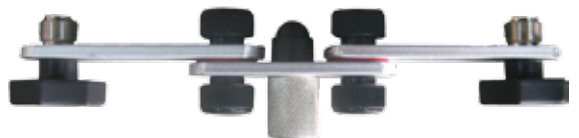

SHEET MUSIC STANDS



Sheet Music Stands

ORCHESTRA SHEET MUSIC STANDS

- Manufactured using heavy duty steel tubing and high-grade hardware
- Available in scratch-resistant, baked-on, non-reflective, black enamel finish
- Feature removable sheet music holder



MS/332

- Heavy-duty orchestra sheet music stand with removable wood music holder

Sheet music holder dimensions:

Width:	21.7" - 55 cm
Height:	14.5" - 37 cm
Lip depth:	2.3" - 6 cm
Height adjustment range:	29.5" to 50.8" 75 cm to 129 cm
Folded height:	30.02" - 76.5 cm
Weight:	9.1 lb - 4.1 kg
Color:	Black Metal with Cherry wood top



MS/320

- Sheet Music Stand with Foldable 3-Page Sheet Music Holder
- Manufactured using heavy duty steel tubing and high-grade hardware
- Solid zinc-alloy tripod leg base to ensure the maximum stability grade demanded by the pros
- Available in scratch-resistant, non-reflective, black enamel finish

Sheet Music holder dimensions

Width:	from 18.9" to 38.6" from 48 to 98 cm
Height:	13" - 33 cm
Lip depth:	2.1" - 5.5 cm
Height adjustment range:	from 29.5" to 50.8" from 75 to 129 cm
Diameter of leg spread:	30" - 76 cm
Weight:	11.7 lb - 5.3 kg
Color:	Black

MS/766 ORCHESTRA SHEET MUSIC STAND

MS/766

Orchestra sheet music stand

- Elegant, contemporary design, this music stand is built for professional use and represents the best option for venues such as schools, music conservatories, concert halls and theatres.
- Collapsible 3-piece design makes it quick to set up and easy to stow when not in use.
- Solid steel, heavy-duty, all-welded tripod base provides absolute stability and takes up a very small footprint.
- The outer mast, baked with a scratch-resistant black powder coating, screws firmly into the base to grant a safe, non-wobbly support to the heaviest music score loads.
- Chrome-finish telescoping shaft can be smoothly set at any height position from 31.5" to 53.15" (80 to 135 cm) using the knobless, one-handed height adjustment friction mechanism.
- The removable, robust yet lightweight all-aluminium music holder is ribbed for extra strength and is large enough to hold a 3-page score, but will also safely accommodate laptops and tablets.
- Optional MST/767 cart for up to 10 orchestra sheet music stands is available to speed up transport and facilitate storage.

Sheet music holder dimensions:

Width:	19.9" - 50.5 cm
Height:	12.6" - 32 cm
Lip depth:	2.2" - 5.6 cm
Height adjustment range:	31.5" to 53.15" 80 cm to 135 cm
Folded height:	35.43" - 90 cm
Diameter of leg spread:	19.68" - 50 cm
Weight:	6 lb - 2.7 kg
Color:	Black with chrome telescoping mast



MST/767

Storage cart for sheet music stands

- Holds up to 10 orchestra sheet music stands model MS/766
- Allows fast removal and easy racking of music stands, as well as neat storage in a very small space
- Designed for indoor use, easy to maneuver on all floor surfaces
- Sturdy steel construction for safe support and years of reliability, this practical cart features durable powder coated finish and roller bearing wheels

Cart dimensions:

Height:	43" - 109.2 cm
Width:	22" - 55.9 cm
Length:	5' - 151.5 cm
Weight:	31.1 lb - 14 kg
Color:	Black



Sheet Music Stands

ORCHESTRA SHEET MUSIC STANDS WITH ALL METAL PERFORATED MUSIC HOLDER

- Manufactured using heavy duty steel tubing and high-grade hardware
- Sturdy tripod leg base design ensures maximum stability and folds compact for easy transport
- Available in scratch-resistant, baked-on, non-reflective, black enamel finish



Details of music desk connection device on MS-331

MS/331

- Sheet Music Stand with All Metal Perforated Music Holder
- Heavy-duty construction

MS/331 W/BAG

Music stand MS/331 supplied with nylon carrying bag

Sheet Music holder dimensions:

Width:	20.5" - 52 cm
Height:	14" - 35.5 cm
Lip depth:	2.1" - 5.5 cm
Height adjustment range:	29.5" to 50.8" 75 to 129 cm
Diameter of leg spread:	30" - 76 cm
Weight:	11 lb - 5 kg
Color:	Black



Details of music desk connection device on MS-330

MS/330

- Sheet Music Stand with All Metal Perforated Music Holder

MS/330 W/BAG

Music stand MS/330 supplied with nylon carrying bag

Sheet music holder dimensions:

Width:	18.7" - 47.5 cm
Height:	13.6" - 34.5 cm
Lip depth:	2" - 5 cm
Height adjustment range:	29.5" to 50.8" 75 cm to 129 cm
Folded Height:	30" - 76.5 cm
Diameter of leg spread:	24" - 61 cm
Weight:	7.3 lb - 3.3 Kg
Color:	Black



MS/334

- Lightweight portable sheet music stand with nylon carrying bag

Sheet music holder dimensions:	
Width:	20" - 51 cm
Height:	11.77" - 30 cm
Bottom Lip depth:	2.3" - 2 cm
Height adjustment range:	20.41" to 51.41" 52 cm to 131 cm
Folded Height:	23.15" - 59 cm
Diameter of leg spread:	22.37" - 57 cm
Weight:	2.2 lb - 1 Kg
Color:	Black

MS/335

- Medium-weight, portable sheet music stand with nylon carrying bag (heavier version of the MS/334 sheet music stand)

Sheet music holder dimensions:	
Width:	20" - 51 cm
Height:	11.77" - 30 cm
Bottom Lip depth:	2.3" - 2 cm
Height adjustment range:	20.41" to 51.41" 52 cm to 131 cm
Folded Height:	23.15" - 59 cm
Diameter of leg spread:	22.37" - 57 cm
Weight:	3.3 lb - 1.5 Kg
Color:	Black



Sheet Music Stands



MS/307

Color:

Black

- Lampholder for 220 Volt Power for use with an E14 type bulb (not supplied)
- Can be easily fixed to almost all music stands



MS/22LED

Color:

Black

- LED light (with 4 LED's) for sheet music stands
- Designed with latest LED technology, this lamp can be powered either with 3 batteries (AAA) or with USB DC power cable, both of which are included with the lamp.
- Fully adjustable, flexible arms allow to conveniently position light beam over music desk.
- Ingeniously designed clamp allows for connection of the lamp to any music stand or table top surface up to 1" (25 mm) thick.
- This versatile, compact lamp can also be used as a reading, camping or workshop light, and is the perfect solution to illuminate your laptop.



MS/19LED

Color: Black

- LED light with 10 LED's for orchestra sheet music stands.
- Designed with latest LED energy-efficiency technology to ensure a 100.000 hour lifespan.
- Can be powered either by 3 batteries (AA) or through AC/DC adapter, both of which are included with the lamp.
- Features a 20-hour battery operating time with 3 AA batteries.
- Fully adjustable, flexible arm allows to conveniently position light beam over music desk.
- Ingeniously designed clamp allows for a firm and safe connection of the lamp to any music stand and most table top surfaces.
- Power switch button offers two light level options.
- Available in elegant, subtle black finish.



PL/010LED

- LED lamp with 10 LED lights for pianos
- Designed with latest LED energy-efficiency technology to ensure a 100.000 hour lifespan.
- Can be powered either by 3 batteries (AAA) or through AC/DC adapter (5V → 500 mA), both of which are included with the lamp.
- Features a 20-hour battery operating time with 3 AAA batteries.
- Tilttable arm allows to conveniently position light beam over sheet music.
- Heavy metal base for a stable and safe use of the lamp on pianos and any other table top surface.
- Power switch button offers two light level options.
- Available in elegant, subtle black finish.

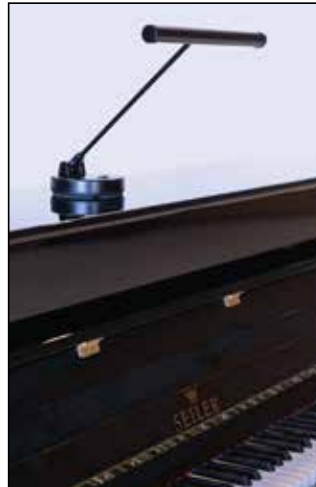

A/107

- Clamp-on Boom Arm Attachment
- Add microphones to your music stand without the congestion of more stands
- Perfect for mic'ing saxophones, drums, acoustic guitars, etc.
- Rubber-tipped 8 mm lock screw will not strip-out when tightened or scratch mic stand
- Heavy, thick metal clamp securely attaches to mast of almost any standard music stand

Boom length: 30" - 76.2 cm
 Vertical pole height: 10" - 25.4 cm
 Clamp opening: 0.55" to 1.18"
 14 to 30 mm
 Weight: 1.6 lb - 0.72 kg
 Color: Black



Sheet Music Stands



MS/327

- Headphone holder
- Clever, safe and practical headphone holder allows musicians to keep their headphone within immediate reach when not in use, hanging it on any instrument stand or multi-media workstation, for use on stage, production studios, in the rehearsal room or at home
- Solid all-metal holder, with soft rubber foam coating on headphone support, to hold it firmly in place, carefully preserving its finish
- By means of its versatile tightening clamp, the MS327 can be securely anchored to any table top surface, and microphone/sheet music/ keyboard/mixer stands of any shape and size ranging from 14 to 48 mm (0.55" to 1.89")

Headphone support width: 3.9" - 10 cm
 Headphone support depth: 1.5" - 4 cm
 Clamp opening: 0.55" to 1.89"
 Weight: 14 to 48 mm
 Color: 0.88 lb - 0.40 kg
 Black



MS/326

- Clamp-on beverage holder
Solid metal holder for bottles, glasses, cans and cups with maximum diameter of 84 mm.
- Heavy, thick metal clamp securely attaches to microphone and sheet music stands with tubing diameter of up to 30 mm.
- Ideal performance companion, keeps your drink at immediate reach when needed!

Height: 18.2" - 8.2 cm
 Diameter: 3.34" - 8.5 cm
 Clamp opening: 0.55" to 1.18"
 Weight: 14 to 30 mm
 Color: 0.81 lb - 0.366 kg
 Black



MS/329

- Large Clamp-on Utility Tray
- Heavy, thick metal clamp securely attaches to mast of almost any standard music stand
- Designed to keep small devices and utilities within immediate reach while performing

Tray dimensions:
 Depth: 8.4" - 21.3 cm
 Width: 8.4" - 21.3 cm
 Lip height: 0.5" - 1.27 cm
 Clamp opening: 0.55" to 1.18"
 Weight: 14 to 30 mm
 Color: 2.6 lb - 1.2 kg
 Black



MS/303

- Small Clamp-on Sheet Music Holder
- Heavy, thick metal clamp securely attaches to mast of almost any standard mic stand

Sheet Music holder dimensions:
 Width: 11.75" - 30 cm
 Height: 7.9" - 20 cm
 Bottom Lip: 2.3" - 6 cm
 Clamp opening: 0.55" to 1.18"
 Weight: 14 to 30 mm
 Color: 2.1 lb - 0.95 kg
 Black

SPEAKER
& LIGHTING STANDS



Speaker & Lighting Stands

QUIK LOK'S HEIGHT ADJUSTABLE ALL-STEEL NEAR-FIELD MONITOR STANDS

- Perfect for home, project or professional recording studios
- All-steel, arc welded construction - NO fibre or chipboard
- Attractive design incorporating cable management
- Solid triangular base with adjustable levelling floor spikes
- Sturdy metal top plate provides steady and safe support
- Available in scratch-resistant, baked-on, non reflective, black enamel finish



BS/300

- Height Adjustable Near-Field Monitor Stand

Speaker plate dimensions:	9" square 23 cm square
Height Positions (5):	32.7", 36", 39", 42", 45.3" 83, 91, 99, 107, 115 cm
Base Size:	17.7" square 45 cm square
Weight capacity:	125 lb - 57 kg
Weight:	10.6 lb - 4.8 kg
Color:	Black

BS/402

- Height Adjustable Near-Field Monitor Stand

Speaker plate dimensions:	9" square 23 cm square
Height Positions (5):	30.7", 34", 37.4", 40.7", 44" 78, 86.5, 95, 103.5, 112 cm
Base Size:	14.5" x 16.1" 37 x 41 cm
Weight capacity:	125 lb - 57 kg
Weight:	11.1 lb - 5 kg
Color:	Black



BS/500 SERIES OF FIXED-HEIGHT ALL-STEEL NEAR-FIELD MONITOR STANDS

- Perfect for home, project or professional recording studios.
- All-steel, arc welded construction - NO fibre or chipboard.
- Attractive design incorporating cable management clips.
- Solid steel base with adjustable levelling floor spikes.
- Sturdy metal top plate, equipped with rubber foam strips, provides steady and safe support.
- Vertical columns can be sand loaded to deaden sound and increase stability.
- Available in scratch-resistant, baked-on, black enamel finish.

BS/536

36" (91 cm) Fixed Height
Near-Field Monitor / Speaker Stand

Speaker plate dimensions: 11" square
28 cm square
Fixed Height: 36" - 91,4 cm
Diameter of base spread: 19.8" - 50,3 cm
Weight capacity: 125 lb - 57 kg
Weight: 10 lb - 4.5 kg
Color: Black

BS/542

42" (106 cm) Fixed Height
Near-Field Monitor / Speaker Stand

Speaker plate dimensions: 11" square
28 cm square
Fixed Height: 42" - 106,7 cm
Diameter of base spread: 19.8" - 50,3 cm
Weight capacity: 125 lb - 57 kg
Weight: 11.1 lb - 5 kg
Color: Black

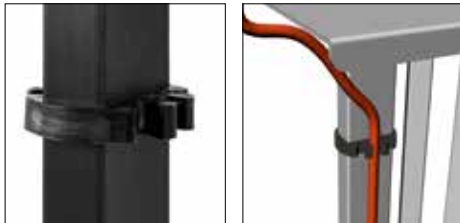

Details of cable management of BS/536 and BS/542 monitor stands

BS/545

40" (100 cm) Fixed Height
Near-Field Monitor / Speaker Stand with cable management steel channel

Speaker plate dimensions: 8.6" x 6.5"
220 x 165 mm
Base Size: 10" square
25 cm square
Fixed Height: 40" - 100 cm
Weight capacity: 125 lb - 57 kg
Weight: 16.6 lb - 7.5 kg
Color: Glossy Black



Details of foam resting pad and floor spikes of BS/545 monitor stand



"X" STYLE SPEAKER/MONITOR STANDS



QL/322

- Small "X" Styled Stereo Speaker Stand

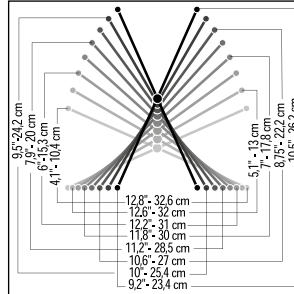

QL/322 Height & width positions

Leg depth:	9.75" - 24.8 cm
Tier depth:	9.75" - 24.8 cm
Folded height:	13.1" - 33.4 cm
Brace tube size:	20 x 15 mm
Weight capacity:	100 lb - 45 kg
Weight:	3.1 lb - 1.4 kg
Color:	Black



BS/313

- Small Tilt-Back Stereo Speaker Stand



Side to side width:	10" - 25.4 cm
Front to back depth range:	11.8" to 15" 30 to 38 cm
Front tier height range:	8.25" to 11" 21 to 28 cm
Back tier height range:	11.4" to 18.6" 29 to 47.2 cm
Brace tube size:	20 x 15 mm
Tier tube diameter:	28 mm
Weight capacity:	75 lb - 33.9 kg
Weight:	3.7 lb - 1.7 kg
Color:	Black



BS/619

- Portable Speaker/Monitor "X" Stand with Collapsible Telescopic Tiers
- Securely holds medium-sized speaker cabinets in tilt-back or straight positions
- Used for side-fill or stage monitor applications
- Folds to compact size for easy transport
- 180 lb (81 Kg) weight capacity

Leg depth:	19.5" - 49.5 cm
Tier depth:	13.75" - 34.9 cm
Folded height:	28" - 71 cm
Upper brace tube size:	25 x 25 mm
Lower brace tube size:	30 x 30 mm
Tier tube size:	30 mm
Weight capacity:	180 lb - 81 kg
Weight:	9.5 lb - 4.3 kg
Color:	Black

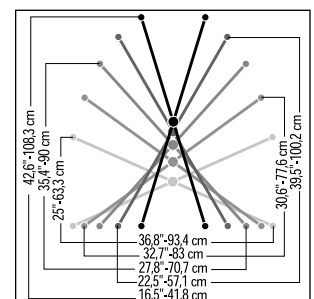

BS/619 Height & width positions

HEAVY DUTY "T" SPEAKER STANDS



- Designed for heavy speaker cabinets including trapezoidal designs
- Capable of holding speaker cabinets up to 300 lb (135 kg) total weight
- 8 different height adjustment positions
- Solid rubber rest pads hold speaker cabinets firmly in place
- Speaker cabinets can be stacked or placed side by side
- Fold down to convenient "T" for easy transport



WS/650

- Large, heavy duty multi-function "T" stand



Height positions (8):	24.25" to 32.5" 61.6 to 81.3 cm
Usable width range:	29.2" to 46.4" 74 to 118 cm
Usable depth range:	17.3" to 27.4" 44 to 69.5 cm
Folded width:	29.2" - 74 cm
Folded height:	24.6" - 62.5 cm
Frame tubing size:	30 x 30 mm
Weight Capacity:	250 lb - 113.1 kg
Weight:	18 lb - 8.1 kg
Color:	Black

Options: WS/551, WS/552, WS/561, WS/562, WS/651, Z/714*, Z/727*, Z/729*, Z/730*, Z/733*, QLX/4**, QLX/5**, IPS/13**, LPH/X**

* Note: can be used only in combination with WS/562 crossbar

** Note: can be used only in combination with WS/651 accessory clamp or Z/727 add-on tiers

WS/640

- Compact, heavy duty multifunction "T" stand



Height positions (8):	24.25" to 32.5" 61.6 to 81.3 cm
Width range:	17" to 26" 43.2 to 66 cm
Depth range:	14" to 17.5" 35.6 to 44.5 cm
Frame tubing size:	30 x 30 mm
Weight Capacity:	300 lb - 135 kg
Weight:	13.1 lb - 5.9 kg
Color:	Black

Options: WS/551, WS/552, WS/651, QLX/4*, QLX/5*, IPS/13*, LPH/X*

* Note: can be used only in combination with WS/651 accessory clamp



QUIK-LOK SPEAKER WALL MOUNTS



QL/953

- Tilt adjustable speaker wall mount with universal speaker adapter plate.
- Perfect for home, stores, restaurants, clubs, theaters, churches and all kinds of commercial applications.
- Extremely strong steel construction and rugged design allow to safely hang on wall the heaviest of speakers up to 15 kg (33.3 lb).
- Heavy duty 4-hole wall plate ensures secure wall connection, while its clean-cut lines are an elegant presence in any kind of environment.
- Features 180° horizontal and 40° tilt adjustability for ideal positioning of speaker.
- Incorporates a universal, versatile speaker plate designed with 10 holes and 2 slots that make it suitable to most popular speakers on the market.
- Available with scratch-resistant, baked-on, non reflective, black enamel finish.

Distance from wall to speaker plate:	4.92" - 12.5 cm
Wall plate size (H x W):	6.3" x 3.54" 16 x 9 cm
Horizontal adjustability:	+/- 90°
Tilt adjustability:	0° to 40°
Weight capacity:	33.3 lb - 15 kg
Weight:	2.88 lb - 1.3 kg
Color:	Black

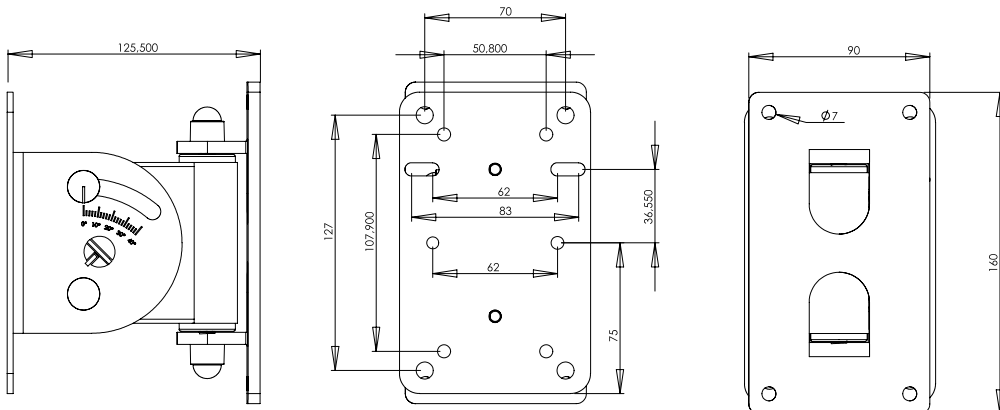



QL/956

- Tilt adjustable speaker wall mount with universal speaker adapter plate.
- Perfect for home, stores, restaurants, clubs, theaters, churches and all kinds of commercial applications.
- Extremely strong steel construction and rugged design allow to safely hang on wall the heaviest of speakers up to 20 kg (44.4 lb).
- Heavy duty 6-hole wall plate ensures secure wall connection, while its clean-cut lines are an elegant presence in any kind of environment.
- Features 180° horizontal and 40° tilt adjustability for ideal positioning of speaker.
- Incorporates a universal, versatile speaker plate designed with 10 holes and 2 slots that make it suitable to most popular speakers on the market.
- Available with scratch-resistant, baked-on, non reflective, black enamel finish.

Distance from wall to speaker plate:	4.92" - 12.5 cm
Wall plate size (H x W):	8.66" x 4.72" 22 x 12 cm
Horizontal adjustability:	+/- 90°
Tilt adjustability:	0° to 40°
Weight capacity:	44.4 lb - 20 kg
Weight:	3.55 lb - 1.6 kg
Color:	Black

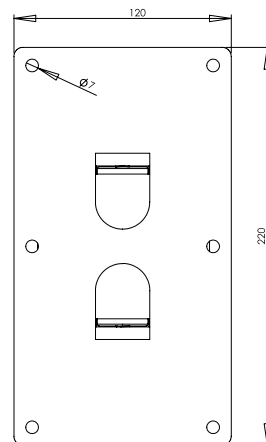
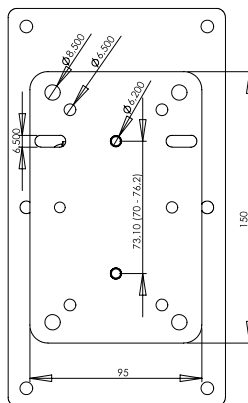
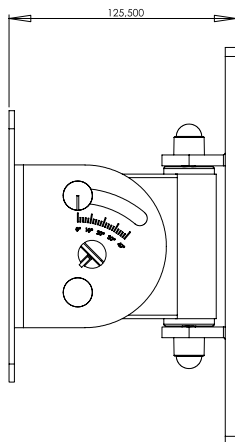

Speaker & Lighting Stands

QL/950

- Tilt adjustable speaker wall bracket for speaker cabinets with 1-3/8" (35 mm) mounting hole.
- Perfect for stores, restaurants, clubs, theaters, churches and all kinds of commercial applications.
- Extremely strong steel construction and rugged design allow to safely hang on wall the heaviest of speakers up to 25 kg (55.5 lb).
- Features horizontal and tilt adjustability for ideal positioning of speaker.
- Supplied with steel safety pin and chain for added security.

Male connection size:	1-3/8" - 35 mm
Distance from wall to connection:	12.8" - 32.6 cm
Wall plate size (H x W):	9.8" x 5.3" 25 x 13.5 cm
Wall plate bolt spacing pattern:	8.3" x 4.5" 21 x 11.5 cm
Horizontal adjustability:	+/- 90°
Tilt adjustment positions (3):	0° - 18° - 36°
Weight capacity:	55.5 lb - 25 kg
Weight:	4.66 lb - 2.1 kg
Color:	Black



QL/95

- Heavy-duty tilt adjustable speaker wall bracket for heavy speaker cabinets with 1-3/8" (35 mm) mounting hole

Male connection size:	1-3/8" - 35 mm
Distance from wall to connection:	11.8" - 30 cm
Wall plate height:	7.5" - 19 cm
Horizontal adjustability:	360°
Weight capacity:	133 lb - 60 kg
Weight:	5.4 lb - 2.45 kg
Color:	Black

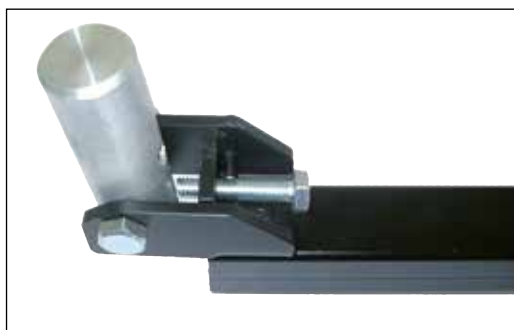

SB/781

- Tilt adjustable speaker wall bracket for speaker cabinets with 1-3/8" (35 mm) mounting hole.
- Perfect for stores, restaurants, clubs, theaters, churches and all kinds of commercial applications.
- Extremely strong steel construction and rugged design allow to safely hang on wall the heaviest of speakers up to 40 kg (88.8 lb).
- Features 3 tilt adjustment positions for ideal positioning of speaker.
- Rod support distance from the wall can be adjusted to 3 positions to perfectly conform to speaker's depth.
- Supplied with steel safety pin and chain for added security.

Male connection size:	1-3/8" - 35 mm
Distance from wall to connection:	9.6"-11.4"-13.2" 24.5 - 29 - 33.5 cm
Wall bracket size (H x W):	19.1" x 3.9" 48.5 x 10 cm
Tilt adjustment positions (3):	0° - 5° - 13°
Frame tube size:	30 x 30 mm
Weight capacity:	88.8 lb - 40 kg
Weight:	6.2 lb - 2.8 kg
Color:	Black



QL/958

- Near-field monitor wall bracket
- Perfect for home, project or professional recording studios.
- Extremely strong steel construction and rugged design allow to safely accommodate on the wall near-field monitors/speakers, at any desired height, right next to your music project station.
- Sturdy metal top plate, equipped with rubber foam strips, provides steady and safe support for near-field monitors/speakers up to 35 kg (77.7 lb).
- This versatile shelf is also the ideal solution for securely holding computer peripherals, audio/video components, compact Hi-Fi systems, etc.
- Features horizontal adjustability (+/- 90°) for ideal positioning of speaker.
- Available in scratch-resistant, baked-on, non reflective, black enamel finish.

Speaker plate dimensions:	9" square 23 cm square
Total depth of wall bracket:	17.36" - 44.1 cm
Wall plate size (H x W):	9.8" x 5.3" 25 x 13.5 cm
Wall plate bolt spacing pattern:	8.3" x 4.5" 21 x 11.5 cm
Horizontal adjustability:	+/- 90°
Weight capacity:	77.7 lb - 35 kg
Weight:	5.55 lb - 2.5 kg
Color:	Black



Speaker & Lighting Stands

ALUMINUM & STEEL SPEAKER STANDS WITH 1-3/8" (35 mm) CENTER TUBE

- Strong lightweight, portable design
- Steel safety pin and chain with snap lock holder on collar
- Supplied with nylon adapter for 38 mm (1.5") speaker cabinet mounts
- Available in anodized black finish
- Limited lifetime warranty

S/171

- Tripod speaker stand with aluminum center tube and steel legs for added strength.

Min to Max height range:	42.9" to 80.7" 109 to 205 cm
Base spread diameter:	24" to 47.2" 61 to 120 cm
Center tube diameter:	1.375" - 35 mm
Folded height:	42.2" - 107 cm
Weight capacity:	100 lb- 45 kg
Weight:	4.45 lb - 2 kg
Color:	Black



The polycarbonate leg joint found on the S/171 provides a neat and elegant look to the stand, while ensuring maximum stability



Snap lock holder on height adjustment collar prevents the safety pin from scratching the tube's finish during transport



The 38 mm (1-1/2") add-on top plastic cap found on the S/171 allows to accommodate different standard speaker mounting seats.

S/171PAK

- Set of two S/171 tripod speaker stands and nylon carrying bag.



S/173

- Aluminum tripod speaker stand with 35/38 mm reversible tube

Min to Max height range:	42.9" to 80.7" 109 to 205 cm
Base spread diameter:	24" to 47.2" 61 to 120 cm
Center tube diameter:	1-3/8" - 1-1/2" 35 - 38 mm
Folded height:	41.2" - 105 cm
Weight capacity:	100 lb - 45 kg
Weight:	4.45 lb - 2.0 kg
Color:	Black



The polycarbonate leg joint found on the S/173 & S/176 provides a neat and elegant look to the stand, while ensuring maximum stability



Snap lock holder on height adjustment collar prevents the safety pin from scratching the tube's finish during transport



The S/173 & S/176 feature a reversible 1-1/2" (38 mm) tube that accommodates 1-1/2" (38 mm) or 1-3/8" (35 mm) speaker mounts with no separate adapters

S/176

- Aluminum tripod speaker/lighting stand with 35/38 mm reversible tube

Min to max height range:	6.1' to 10' 185 to 307 cm
Base spread diameter:	48.8" to 60.6" 124 to 154 cm
Center tube diameter:	1-3/8" - 1-1/2" 35 - 38 mm
Folded height:	64.5" - 164 cm
Weight capacity:	125 lb - 56.6 kg
Weight:	8 lb - 3.6 kg
Color:	Black

CB 6/2

- Nylon Tote Bag for two S/171, SP/282, SP/770, S/173 or SP/180 speaker stands



Speaker & Lighting Stands

DELUXE ALUMINUM PNEUMATIC SPEAKER/LIGHTING STANDS WITH 1-3/8" (35 mm) CENTER TUBE

- Superior air-cushion design gently and safely lowers speaker cabinets eliminating sudden drops
- Non-strip out height adjustment and leg joint collar hardware with block tightening clamp assembly
- Heavy duty aluminium alloy leg joint provides strength and stability
- Strong lightweight, portable design
- Steel safety pin and chain with snap lock holder on collar
- Supplied with adapter for 38 mm (1.5") speaker cabinet mounts
- Available in silver satin or anodized black finishes
- Limited lifetime warranty

SP/180

- 6 ft (180 cm) Speaker Stand
Featuring air-cushion device

Min to max height range:	48" to 72" 122 to 183 cm
Base spread diameter:	38.5" to 60" 98 to 152 cm
Center tube diameter:	1.375" - 35 mm
Folded height:	42.5" - 108 cm
Weight capacity:	125 lb - 56.6 kg
Weight:	6.4 lb - 2.9 kg
Color:	Silver or Black



Superior air-cushion design gently and safely lowers speaker cabinets eliminating sudden drops



The 38 mm (1-1/2") add-on top plastic cap allows to accommodate different standard speaker mounting seats



Heavy duty aluminium alloy leg joint, with metal block tightening clamp assembly, provides strength and stability



Snap lock holder on height adjustment collar prevents the safety pin from scratching the tube's finish during transport



Sleek, modern design rubber feet will hold speaker stand firmly in place

SP/180BK PAK

- Set of two SP/180BK tripod speaker stands and nylon carrying bag.

Min to max height range: 48" to 72"
122 to 183 cm
Base spread diameter: 38.5" to 60"
98 to 152 cm
Center tube diameter: 1.375" - 35 mm
Folded height: 42.5" - 108 cm
Weight capacity: 125 lb - 56.6 kg
Weight: 6.4 lb - 2.9 kg
Color: Black



SP/189

- 10 ft (300 cm) Speaker/Lighting Stand Featuring air-cushion device

Min to max height range: 5.8' to 9.8'
175 to 296 cm
Base spread diameter: 48.8" to 73.2"
124 to 186 cm
Center tube diameter: 1.375" - 35 mm
Folded height: 60,6" - 154 cm
Weight capacity: 125 lb - 56,6 kg
Weight: 8 lb - 3,6 kg
Color: Silver or Black



Heavy duty aluminium alloy leg joint, with metal block tightening clamp assembly, provides strength and stability



Snap lock holder on height adjustment collar prevents the safety pin from scratching the tube's finish during transport

Speaker & Lighting Stands

SP/282 "EASY-LIFT" DELUXE ALUMINUM PNEUMATIC SPEAKER STAND WITH 1-3/8" (35 mm) CENTER TUBE

- Innovative "Easy-Lift" height adjustment device allows to raise your speaker cabinet EFFORTLESSLY!
- Superior air-cushion design gently and safely lowers speaker cabinets eliminating sudden drops.
- Non-strip out height adjustment collar and leg joint hardware with block tightening clamp assembly.
- Solid, robust polycarbonate leg joint and height adjustment collar provide strength and stability.
- Height adjustment collar houses a strong tightening knob to eliminate the least wobbling, and a self-engaging steel safety pin for added security. Simply press the collar lever to disengage pin and free the shaft.
- Strong lightweight, portable design.
- Supplied with adapter for 38 mm (1-1/2") speaker cabinet mounts.
- Available in silver satin or anodized black finishes.
- Limited lifetime warranty.



SP/282

- 6 ft (180 cm) Speaker Stand
Featuring Easy-Lift device and
Air-Cushion design

Min to max height range:	48" to 72" 122 to 183 cm
Base spread diameter:	38.5" to 60" 98 to 152 cm
Center tube diameter:	1.375" - 35 mm
Folded height:	42.5" - 108 cm
Weight capacity:	125 lb - 56.6 kg
Weight:	6 lb - 2.7 kg
Color:	Silver or Black



Height adjustment collar houses a strong tightening knob to eliminate the least wobbling, and a self-engaging steel safety pin for added security. Simply press the collar lever to disengage pin and free the shaft



The 38 mm (1-1/2") add-on top plastic cap allows to accommodate different standard speaker mounting seats



Solid, robust polycarbonate leg joint, with nylon block tightening clamp assembly, provides strength and stability



Sleek, modern design rubber feet will hold speaker stand firmly in place



The innovative "Easy-Lift" height adjustment device allows to raise your speaker cabinet EFFORTLESSLY! Place your speaker on the stand with the shaft at its lowest height position (a). Then start raising the shaft to the desired height (b): the steel security pin located in the height adjustment collar will self-engage every 4" (10 cm), locking the shaft in place and allowing you to pause, and then continue from there to the next height position, proceeding with lifting the speaker's weight in small, effortless increments. Once the safety pin catches the last position hole and the maximum stand height is reached, tighten the collar knob to eliminate the least wobbling (c).

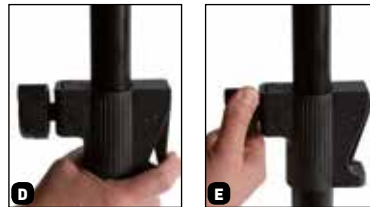

To take down the speaker cabinet, simply press the collar lever to disengage the safety pin (d). Then, making sure not to be in the way of the speaker's descent, loosen the tightening knob to free the shaft (e). Quik Lok's superior air-cushion design will lower the speaker gently and safely, eliminating sudden drops (f).



Speaker & Lighting Stands

SP/770 "QUIK-LIFT" DELUXE ALUMINUM PNEUMATIC SPEAKER STAND WITH 1-3/8" (35 mm) CENTER TUBE

- Innovative "Quik-Lift" air-powered device allows for effortless, lift-assisted set-up of your speaker cabinet!
- Thanks to the pressure of a powerful air charge piston that counterbalances the speaker's weight, the SP/770 will lift up speakers weighing up to 42 lb (19 Kg.) completely by itself: simply position the speaker on the stand at its lowest height position, untighten the security knob and the self-rising shaft will lift up the speaker to the desired height on its own.
- And with the helpful action of its air-powered piston, even raising heavier speakers becomes a simple, easy one-hand operation!
- Superior air-cushion design makes it also possible to gently and safely lower the speaker cabinet, eliminating sudden drops.
- Non-strip out height adjustment collar and leg joint hardware with block tightening clamp assembly.
- Solid, robust polycarbonate leg joint and height adjustment collar, combined with specially-engineered, semi-oval shaped tubing on tripod leg design, provide absolute strength and total stability.
- Height adjustment collar houses a strong tightening knob to eliminate the least wobbling..
- Strong lightweight, portable design.
- Supplied with adapter for 38 mm (1-1/2") speaker cabinet mounts.
- Available in anodized black finish.



SP/770

- 6 ft (180 cm) Speaker Stand
Featuring Quik-Lift Air-Powered
Device

Min to max height range:	46.4" to 73.6" 118 to 187 cm
Base spread diameter:	38.5" to 47.2" 98 to 120 cm
Center tube diameter:	1.375" - 35 mm
Folded height:	43.7" 111 cm
Weight capacity:	125 lb - 56.6 kg
Weight:	9.1 lb - 4.1 kg
Color:	Black



Thanks to the pressure of a powerful air charge piston that counterbalances the speaker's weight, the SP/770 will lift up speakers weighing up to 42 lb (19 Kg.) completely by itself: simply position the speaker on the stand at its lowest height position, untighten the security knob and the self-rising shaft will lift up the speaker to the desired height on its own.



Height adjustment collar houses a strong tightening knob to eliminate the least wobbling.



Sleek, modern design rubber feet will hold speaker stand firmly in place



Solid, robust polycarbonate leg joint and height adjustment collar, combined with specially-engineered, semi-oval shaped tubing on tripod leg design, provide absolute strength and total stability.

DSP/390

- Universal Mount for LED flat screens, LCD displays and video monitors up to 40", built with VESA bolt pattern mounting standards.
- Designed for mounting of flat screen TV's on a floor stand, it easily mounts over the top of any speaker/lighting stand built using 35 mm diameter round tubing, and securely connects to it by means of a practical clamping device.
- Mounting plate features up-and down tilt adjustments (0°/+10°) and full side-to-side adjustment (360°).
- Manufactured using high-strength steel sheet metal.
- Includes all VESA hardware for fast and simple installation.

Plate dimensions:	9" x 9" 23 x 23 cm
VESA compliant:	Including VESA 75x75mm 100x100mm 100 x 200mm 200x200mm
Weight:	3.66 lb - 1.65 kg
Weight capacity:	66.6 lb - 30 kg
Color:	Black



SLS11 WIND-UP STEEL SPEAKER STAND WITH HAND CRANK MECHANISM



SLS/11

- Wind-up steel speaker stand with hand crank mechanism
- User-friendly hand crank device allows for effortless, lift-assisted set-up of any speaker cabinet with 1-3/8" (35 mm) mounting hole. Even raising the heaviest speakers becomes a simple, easy one-hand operation!
- Extremely strong steel construction and rugged design with double bracing tripod leg allow to safely and comfortably lift up speakers weighing up to 111 lb (50 Kg.).
- Solid, robust zinc-alloy leg-joint and height adjustment collar provide absolute strength and total stability.
- Height adjustment collar houses a strong tightening knob to eliminate the least wobbling and steel safety pin for added security.
- Supplied with adapter for 38 mm (1-1/2") speaker cabinet mounts.
- Available with scratch-resistant, baked-on, non reflective, black enamel finish.

Min to max height range:	59" to 94.4" 150 to 240 cm
Base spread diameter:	51.2" to 65" 130 to 165 cm
Center tube diameter:	1.375" - 35 mm
Folded height:	58.26" - 148 cm
Weight capacity:	111 lb - 50 kg
Weight:	20.2 lb - 9.1 kg
Color:	Black



S/226 ALL-STEEL SPOT MONITOR / AMP STAND

- Designed to hold spot monitors and instrument amplifiers at ear level or lower.
- Accommodates all kinds of mounting bracket configurations including 1" (25 mm) diameter cups, standard mic stand thread with 1/4" and 3/8" connections
- Non-strip-out height adjustment and leg joint collar hardware with block tightening clamp assembly
- Strong lightweight, portable design
- 90 lb (40.7 kg) weight capacity
- Maximum height of 5 ft. (150 cm)
- Baked-on black enamel finish

S/226

- All-Steel Spot Monitor / Amp Stand

Min. to max. height range: 36" to 59"
91.4 to 150 cm
Center tube diameter: 1" - 25 mm
Folded height: 36" - 91.4 cm
Weight capacity: 90 lb - 40.7 kg
Weight: 7.1 lb - 3.2 kg
Color: Black



The S/226 is supplied with both a 1/4" and a 3/8" standard mic stand thread connection



Speaker & Lighting Stands



S/213



S/203



S/333



S/203 extension tube in application

S/213

- Double ended fixed length extension tube for connection of satellite systems
- All-steel construction

Length:	31.5" - 80 cm
Center tube diameter:	1.375" - 35 mm
Weight capacity:	125 lb - 56.6 kg
Weight:	4.4 lb - 2 kg
Color:	Black

S/203

- Telescopic, double ended variable length extension tube for connection of satellite systems
- Allows for the most ideal separation of subwoofer and speaker
- All-steel construction with locking pin to prevent accident descent and vibration

Height range:	28.7" to 44" 73 to 112 cm
Center tube diameter:	1.375" - 35 mm
Weight capacity:	125 lb - 56.6 kg
Weight:	5.5 lb - 2.5 kg
Color:	Black

S/333

- Telescopic, variable length, extension tube for connection of satellite speaker systems
- Double ended rod, 35mm diameter on one side, and 40mm diameter built with a M20 threaded bolt on the other end, for connection to subwoofer threaded flange
- Allows for the most ideal separation of subwoofer and speaker
- All-steel construction, with locking pin to prevent accident descent and vibration

Height range:	31.5" to 43.3" 80 to 110 cm
Top tube diameter:	1.375" - 35 mm
Bottom tube diameter:	1.57" - 40 mm (with built-in M20 threaded bolt)
Weight capacity:	125 lb - 56.6 kg
Weight:	3.4 lb - 1.53 kg
Color:	Black



Double ended rod, 35mm diameter on one side, and 40mm diameter built with a M20 threaded bolt on the other end, for connection to subwoofer threaded flange



SB/202

- Twin-Speaker Crossbar with 1-3/8" (35 mm) Connections

Weight capacity*:	150 lb - 67 kg
Width:	19" - 48.5 cm
Color:	Black

*(Default to weight limit of stand used)



SC/3535

- Speaker tilt connector
- Allows to adjust the tilt angle of speakers from 0° to 15°
- The lower section is designed to fit on any speaker stand having 35mm diameter tubing
- The top section will accommodate any speaker with 35 mm (1-3/8") speaker cabinet mount
- Two security knobs to firmly connect adaptor to stand and lock speaker into the desired tilt angle position
- All-steel construction

Top section tube diameter: 1.375" - 35 mm
 Weight capacity: 55.5 lb - 25 kg
 Weight: 1.3 lb - 0.6 kg
 Color: Black



SC/936

- Steel adaptor for speaker/lighting stands
- Useful accessory needed for mounting par-cans and U-shaped speaker brackets on speaker/lighting stands with 35mm diameter tubing.
- Features M10 bolt required to secure par-cans and U-shaped speaker brackets firmly in place.

Height: 3.94" - 100 mm
 Weight: 0.88 lb - 0.4 kg
 Color: Black



SC/3525

- Steel adaptor for mounting 25mm speakers cups on 35mm stand tubing



SC/107

- Steel speaker cup - 35mm (1-3/8") diameter tube mounting hole



SC/235

- Aluminium speaker cup - 35mm (1-3/8") diameter tube mounting hole



Speaker & Lighting Stands

S/195

- Steel Crossbar for 8 Lights / Effects - 39" (100 cm)



Width:	39.3" - 100 cm
Tube size:	35 mm
Weight capacity*:	125 lb - 56 kg
Weight:	2.8 lb - 1.3 kg
Color:	Black

*[Default to weight limit of stand used]

S/191-1.5

- Aluminum crossbar - 5 ft (150 cm)
- Holds 8 par cans or effects up to 125 lb - 56 kg
- Made of strong aluminum tubing
- Comes complete with light mounting hardware
- 1.5" - 38 mm heavy duty, aluminum-alloy "T" connector



Width:	5' - 150 cm
Tube size:	1.5" - 38 mm
Weight capacity*:	125 lb - 56 kg
Color:	Black or Silver

*[Default to weight limit of stand used]

STS/14

- Aluminum truss system with 10 ft (300 cm) ladder trussing (ladder mounting kit included).

Min. to max height range:	63.8" to 128" 162 to 325 cm
Width:	10 ft - 300 cm
Weight capacity:	222 lb - 100 kg (evenly distributed)
Color:	Black

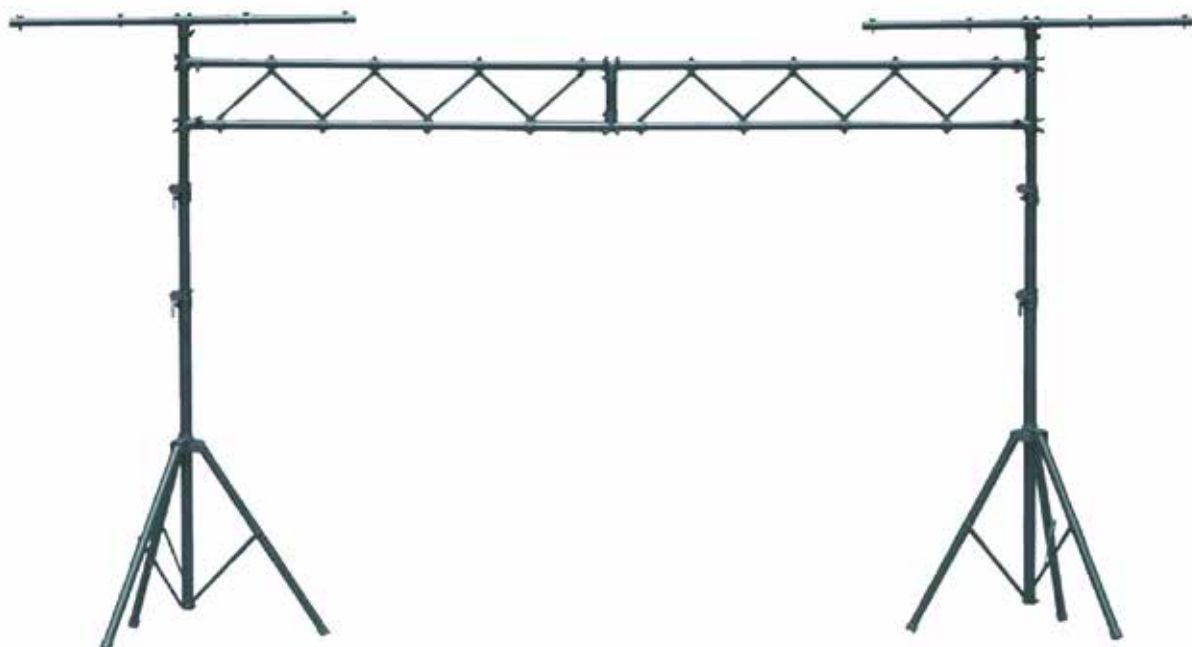

SLS/15

- 13 ft. Heavy-Duty, Steel Crank-Up Lighting / Truss Stand

Min. to max. height range: from 68.9" to 158"
from 175 to 400 cm
Base spread diameter: from 45.3" to 66.1"
from 115 to 168 cm
Center tube diameter: 1-3/8" - 35 mm
Folded height: 68.8" - 135 cm
Weight capacity: 189 lb - 85 kg
Weight: 55.5 lb - 25 kg



QCC/1

- Snap-on cable management Clip, designed to help manage the tangle of extension cords, A/C lines and control wires
- Mounts to any 1-3/8" (35 mm) or 1-1/2" (38 mm) tubing
- Can be bolted or riveted into place



QLC/1U

- Universal "C" Clamp
- Universal par can / light effect clamp that can be mounted on any size tubing 1" to 2" (25 to 50 mm) diameter
- Made out of heavy gauge steel
- Tighten clamp onto truss by hand
- No wrenches needed



Speaker & Lighting Stands



GUITAR STANDS

A close-up photograph of a guitar bridge mounted on a black stand. The bridge is made of light-colored wood and has several strings attached. The stand is black and has the word 'QUIKLOK' printed in white on its side. The background is blurred, showing a wooden surface and a red object.

QUIKLOK

GS/500 SERIES OF UNIVERSAL GUITAR STANDS WITH SELF-LOCKING YOKE

- Quik Lok introduces the new GS/500 Series of universal guitar stands, combining the elegance of a contemporary design with an ingenious device (patent-pending) that allows for a secure and well balanced support of any size electric/acoustic guitar and bass.
- When the guitar is placed into the stand yoke, the instrument's weight will automatically drive the lateral safety barriers incorporated in the yoke to engage. The safety barriers turn down to lock the guitar neck securely in place, preventing the instrument from accidentally falling off the stand. When the guitar is lifted from the stand the security barriers will simultaneously turn back to their original position to free the instrument.
- Durable, smooth velveteen foam padding on yoke protects guitars from scratches and will not mar finish.
- The neck holder height can be easily adjusted to multiple positions to accommodate any size guitar.
- The guitar body rests comfortably and safely against metal supports that are adequately covered with velveteen foam cushioning to protect and avoid marring the guitar finish.
- Collapsible neck allows to fold the stand to a slender shape for easy storage and transport.
- The GS/500 Series comprises three floor stand models, for one, two and three electric/acoustic or bass guitars.

GS/508

Universal Acoustic/Electric Guitar Stand With Self-Locking Yoke

Height positions range:	27.2" to 40.5" 69 to 103 cm
Base width:	24.8" - 63 cm
Base depth:	18.1" - 46 cm
Folded size:	23.4" x 3.7" x 4.3" 67 x 9.5 x 11 cm
Yoke inner width:	0.20" - 53 mm
Weight capacity:	35.5 lb - 16 kg
Weight:	3.4 lb - 1.54 kg
Color:	Black



Collapsible neck allows to fold the stand to a slender shape for easy storage and transport.



When the guitar is placed into the stand yoke, the instrument's weight will automatically drive the lateral safety barriers to turn down and lock the guitar neck securely in place, preventing the instrument from accidentally falling off the stand.



Details of self-locking yoke featuring durable, smooth velveteen foam padding that protects guitars from scratches and will not mar finish.



The neck holder height found on model GS/508 can be easily adjusted to multiple positions by simply releasing the extension lever and then clamping it back into position for a secure grip.

GS/528

Universal Dual Acoustic/Electric
Guitar Stand With Self-Locking
Yoke



Height positions range: 35.43" to 47.2"
90 to 120 cm
Diameter of leg spread: 27.56" - 70 cm
Folded size: 34.3" x 6.9" x 4.3"
87 x 17.5 x 11 cm
Yoke inner width: 0.20" - 53 mm
Weight capacity: 44.44 lb - 20 kg
Weight: 5.84 lb - 2.63 kg
Color: Black



Collapsible neck and guitar body rests allow to fold the stand to a slender shape for easy storage and transport.



GS/538

Universal Triple Acoustic/Electric
Guitar Stand With Self-Locking
Yoke



Height positions range: 35.43" to 47.2"
90 to 120 cm
Diameter of leg spread: 29.13" - 74 cm
Folded size: 34.3" x 6.9" x 6.5"
87 x 17.5 x 16.5 cm
Yoke inner width: 0.20" - 53 mm
Weight capacity: 66.66 lb - 30 kg
Weight: 7.06 lb - 3.18 kg
Color: Black



Collapsible neck and guitar body rests allow to fold the stand to a slender shape for easy storage and transport.



Guitars Stands

DELUXE LOW "A" FRAME GUITAR STANDS

- The most popular guitar stands ever made, now redesigned for a new contemporary and modern look
- Solidly constructed with high-grade steel and arc-welded joints, in a true integration with high-tech style
- Soft, rubberized cushioning on cradles holds guitar firmly in place without damaging finish
- Firmly locks in open position and folds flat for easy transport, by operating the spring-loaded release lever located in the back of the upper disc
- Available in black baked-on enamel finish

QL/631

- Low "A" Frame Electric Guitar Stand

Depth:	11.4" - 29 cm
Set-up width:	14.2" - 36 cm
Set-up height:	16.9" - 43 cm
Fold-up height:	17.7" - 45 cm
Cradle depth opening:	2" - 5 cm
Square steel tube size:	30 x 15 mm
Round steel tube size:	30 mm
Weight:	3.7 lb - 1.65 kg
Color:	Black

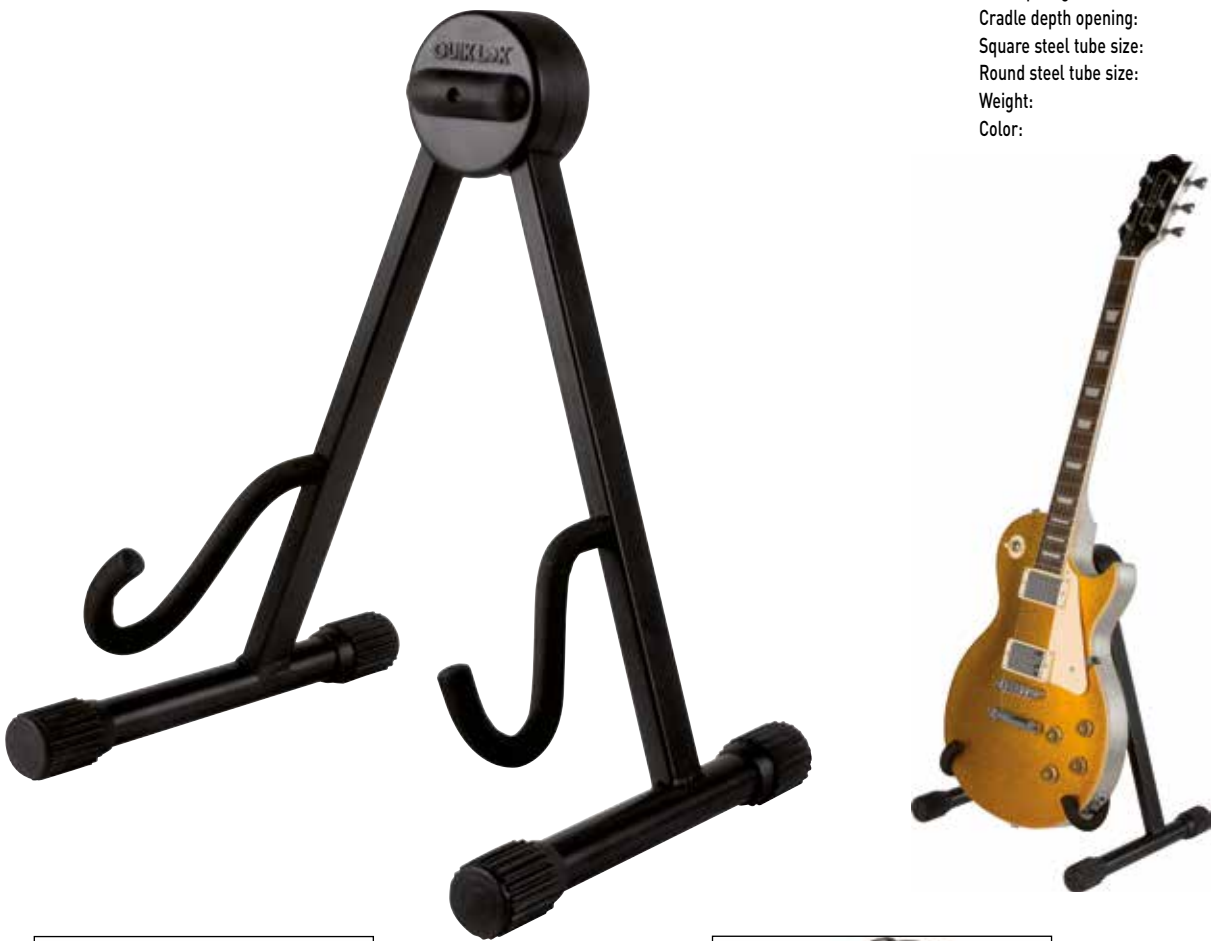

Operating the spring-loaded release lever located in the back of the upper disc allows to quickly set the stand in perfect open position and fold it flat for easy storage



Front top view of stand showing a special built-in soft rubber pad for guitar body to rest safely, without risk of marring the finish

QL/632

- Low "A" Frame Dreadnought
Guitar Stand



Depth:	11.4" - 29 cm
Set-up width:	14.2" - 36 cm
Set-up height:	16.9" - 43 cm
Fold-up height:	17.7" - 45 cm
Cradle depth opening:	5.1" - 13 cm
Square steel tube size:	30 x 15 mm
Round steel tube size:	30 mm
Weight:	3.7 lb - 1.65 kg
Color:	Black



QL/633

- Low "A" Frame Acoustic Guitar
Stand



Depth:	11.4" - 29 cm
Set-up width:	14.2" - 36 cm
Set-up height:	16.9" - 43 cm
Fold-up height:	17.7" - 45 cm
Cradle depth opening:	4.3" - 11 cm
Square steel tube size:	30 x 15 mm
Round steel tube size:	30 mm
Weight:	3.7 lb - 1.65 kg
Color:	Black



Guitars Stands

GS/436

- Low "A" Frame Electric Guitar Stand

Depth:	11.4" - 29 cm
Set-up width:	14.2" - 36 cm
Set-up height:	16.3" - 41.5 cm
Fold-up height:	17.7" - 45 cm
Cradle depth opening:	2" - 5 cm
Square steel tube size:	30 x 15 mm
Weight:	2.6 lb - 1.2 kg
Color:	Black

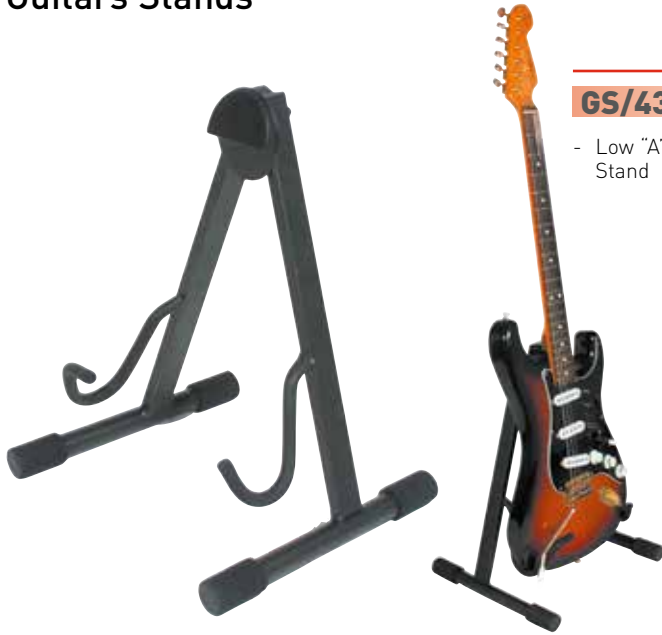

GS/437

- Low "A" Frame Acoustic Guitar Stand

Depth:	11.4" - 29 cm
Set-up width:	14.2" - 36 cm
Set-up height:	16.3" - 41.5 cm
Fold-up height:	17.7" - 45 cm
Cradle depth opening:	4.3" - 11 cm
Square steel tube size:	30 x 15 mm
Weight:	2.6 lb - 1.2 kg
Color:	Black



Front top view of stand showing a special built-in soft rubber pad for guitar body to rest safely, without risk of marring the finish

GS/438

- Low "A" Frame Universal Acoustic/Electric Guitar Stand
- Lower cradles designed to hold either acoustic or electric guitars

Depth:	11.4" - 29 cm
Set-up width:	14.2" - 36 cm
Set-up height:	16.3" - 41.5 cm
Fold-up height:	17.7" - 45 cm
Cradle depth opening:	5.1" - 135 cm
Square steel tube size:	30 x 15 mm
Weight:	2.6 lb - 1.2 kg
Color:	Black

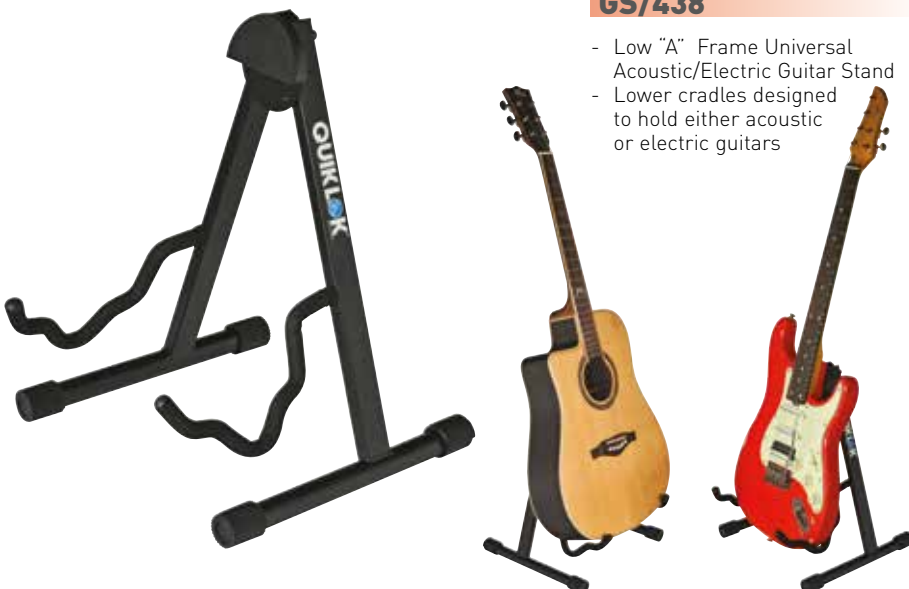

GI/8 COMPACT, PORTABLE UNIVERSAL GUITAR STAND

- Lower cradles are designed to hold either acoustic or electric/bass guitars
- ABS composite material injection-moulded base for high impact resistance provides a sturdy and stable support for any size and weight guitar instrument
- Solidly constructed high-grade steel cradles and backrest to hold the heaviest guitars firmly and safely in place
- Pull-out floor metal stabilizer provided to grant extra stability to the stand and absolute safety to the guitar when resting on uneven floors
- Special foam cushioning on all contact points provides a soft and safe support for the guitars, protecting them from damages without marring their finish
- Collapsible design of backrest and cradles allows to quickly fold the stand down to a compact, ultra light, space-saving size for easy storage and convenient portability - Fits most size guitar soft bag pouches!!!
- Ideal for use on stage, in studios or at home, but also great for store displays and trade shows

GI/8

- Compact, portable universal guitar stand

Set-up width & depth:	10.3" - 26 cm
Set-up height:	10.8" - 27.5 cm
Folded dimensions:	10.3" x 1.6"
	26 x 4.2 cm
Cradle depth opening:	4.72" - 12 cm
Weight:	1.48 lb - 0.67 kg
Color:	Black



Folds down to a compact, ultra light, space-saving size of 10.3" x 1.6" (26 x 4.2 cm) for easy storage and convenient portability



Fits most size guitar soft bag pouches!!!

Guitars Stands

NEW GS/434 & GS/435 COMPACT PORTABLE GUITAR STANDS

- Low "A" frame portable guitar stands.
- Ultra light, compact, folding design makes them ideal for transport and storage in a guitar soft bag pouch.
- Cradles covered with special injection-moulded soft rubber allow for the guitar to rest firmly in place without risk of damaging the finish.



GS/434

- Compact electric guitar stand



Set-up depth:	13.6" - 34.5 cm
Set-up width:	13" - 33 cm
Set-up height:	13.8" - 35 cm
Fold-up dimensions:	3.5"W x 16.5"H x 2"D (8.9W x 42H x 5D cm)
Cradle depth opening:	2" - 5 cm
Weight:	1.44 lb - 0.65 kg
Color:	Black



GS/435

- Compact acoustic guitar stand



Set-up depth:	16.9" - 43 cm
Set-up width:	13" - 33 cm
Set-up height:	13.8" - 35 cm
Fold-up dimensions:	6.8"W x 16.5"H x 2"D (17.4W x 42H x 5D cm)
Cradle depth opening:	5.3" - 13.5 cm
Weight:	1.55 lb - 0.7 kg
Color:	Black



FS/01

- Footrest for guitar players

QL/791 FULLY ADJUSTABLE GUITAR STAND FOR ANY SIZE OR SHAPE ELECTRIC GUITAR OR BASS

- Patented design easily allows the QL/791 to conform to the contour of any electric guitar or bass
- Each lower guitar cradle independently adjusts, in both height and angle, out of the way of knobs, switches or input jacks
- Solidly constructed with high-grade steel and arc-welded joints for years of dependability
- Soft, rubberized cushioning protects guitars from scratches and will not mar finish
- Cushioned protector on height adjustable neck holder prevents the guitar from falling out of stand and is supplied with a guitar pick holder
- Rear adjustment knob firmly locks stand in any open position up to 15" (38 cm) wide and at the same time sets neck holder at the desired height
- Rotating leveling foot compensates for uneven floors
- Folds down to a convenient portable size for transport and easy storage

QL/791

- Fully Adjustable Electric Guitar Stand

Depth:	11.8" - 30 cm
Set-up width:	up to 15" - 38 cm
Min to Max Set-up height:	20" to 33.8"
	51 to 86 cm
Fold-up height:	20.5" - 52 cm
Cradle depth opening:	2" - 5 cm
Square steel tube size:	15 x 30 mm
Round steel tube size:	25 mm
Weight:	4.7 lb - 2.1 kg
Color:	Black

Independently height and angle adjustable arms will not interfere with switches, knobs or electrical input jacks, regardless of the configuration.



Rear adjustment knob firmly locks stand in any open position up to 15" (38 cm) wide and at the same time sets neck holder at the desired height.



Guitars Stands

QL/691 THE ONLY GUITAR STAND MADE THAT ADJUSTS TO FIT ANY SIZE OR SHAPE ELECTRIC GUITAR OR BASS

- Patented, unique design easily allows the QL/691 to conform to the contour of any electric guitar or bass
- Each lower guitar cradle independently adjusts out of the way of knobs, switches or input jacks
- Solidly constructed with high-grade steel and arc-welded joints for years of dependability
- Soft, rubberized cushioning protects guitars from scratches and will not mar finish
- Height adjustable neck holder uses a cushioned protector that prevents the guitar from falling out of stand
- Double body pin firmly locks stand in open position
- Folds down to a convenient portable size for transport

QL/691

- Fully Adjustable Electric Guitar Stand



Centre vertical support adjusts up and down depending on the length of the instrument

Durable, lightweight stand easily folds to only 3" x 18" (7.6 x 46 cm)

Rubberized covered steel arms adjust vertically and horizontally to fit the shape of any size electric guitar or bass.

Depth:	11.8" - 30 cm
Set-up width:	13" - 33 cm
Min to Max Set-up height:	31.5" to 18" 80 to 46 cm
Fold-up height:	18.1" - 46 cm
Cradle depth opening:	2" - 5 cm
Square steel tube size:	15 x 30 mm
Round steel tube size:	30 mm
Weight:	5 lb - 2.3 kg
Color:	Black

Adjustable arms will not interfere with switches, knobs or electrical input jacks, regardless of the configuration.



QL/691... the ideal stand for any size or shaped electric guitar or bass!

QL/692

- Universal Acoustic / Electric Guitar Stand
- Lower cradles designed to hold either acoustic or electric guitars
- Solidly constructed with high-grade steel and arc-welded joints for years of dependability
- Soft, rubberized cushioning protects guitars from scratches and will not mar finish
- Height adjustable neck holder
- Folds down to a convenient portable size for transport

Depth:	13.2" - 33.5 cm
Set-up width:	14.4" - 36.5 cm
Min to Max Set-up height:	32.2" to 19.7" 82 to 50 cm
Fold-up height:	20.5" - 52 cm
Cradle depth opening:	5.1" - 13 cm
Square steel tube size:	15 x 30 mm
Round steel tube size:	30 mm
Weight:	4.4 lb - 2 kg
Color:	Black



Double body pin firmly locks stand in open position



QL/694

- Double Universal Acoustic / Electric Guitar Stand
- Double version of the QL/692 capable of holding 2 acoustic, electric or acoustic/electric guitar combinations

Depth:	17.3" - 44 cm
Set-up width:	14.4" - 36.5 cm
Min to Max Set-up height:	32.2" to 19.7" 82 to 50 cm
Fold-up height:	20.5" - 52 cm
Cradle depth opening:	5.1" - 13 cm
Square steel tube size:	15 x 30 mm
Round steel tube size:	30 mm
Weight:	6 lb - 2.7 kg
Color:	Black



Guitars Stands

MULTIPLE UNIVERSAL GUITAR STANDS FOR THREE/FIVE/SEVEN GUITARS

- Lower cradles designed to hold either acoustic or electric guitars firmly in place
- Individual upper and lower cradles, covered with soft, rubberized cushioning protect guitars from scratches and will not mar finish
- Rear locking pin allows to quickly set the stand in perfect open position and fold it down to a convenient portable size for transport without need for tools
- Ideal for use on stage or studios, but also great for store displays, and trade shows
- Equipped with casters for easy mobility

GS/430

- Multiple Universal Guitar Stand for Three Guitars

Set-up depth:	16.7" - 42.5 cm
Set-up width:	21.3" - 54 cm
Set-up height:	31.3" - 79.5 cm
Cradle depth opening:	5.1" - 13 cm
Weight:	10 lb - 4.5 kg
Color:	Black



GS/450

- Multiple Universal Guitar Stand for Five Guitars

Set-up depth:	16.7" - 42.5 cm
Set-up width:	32.7" - 83 cm
Set-up height:	31.3" - 79.5 cm
Cradle depth opening:	5.1" - 13 cm
Weight:	13.7 lb - 6.2 kg
Color:	Black



GS/471

- Multiple Universal Guitar Stand for Seven Guitars

Set-up depth:	16.7" - 42.5 cm
Set-up width:	45.2" - 115 cm
Set-up height:	31.3" - 79.5 cm
Cradle depth opening:	5.1" - 13 cm
Weight:	16.9 lb - 7.6 kg
Color:	Black



Guitars Stands

GS/350 MULTIPLE UNIVERSAL GUITAR STAND

- Designed to hold up to 4 acoustic or 6 electric/bass guitars or a combination of electric and acoustic instruments
- Solidly constructed with high-grade steel to ensure a stable base for supporting up to 6 of the heaviest guitars firmly in place
- Padded backrest and base are covered with special foam cushioning that provides a soft but safe support for the guitars and protects them from damages
- Easily adjustable, foam rubber partition disks located on backrest and base protect guitars from damages
- One-piece design for easy and rapid setup in perfect open position without need for tools
- Collapsible backrest allows to quickly fold the stand down to a compact, lightweight, space-saving size for easy storage and convenient portability
- Ideal for use on stage, in studios or at home, but also great for store displays and trade shows



GS/350

- Multiple Universal Guitar Stand

Set-up depth:	19.3" - 49 cm
Set-up width:	29.5" - 75 cm
Set-up height:	25.2" - 64 cm
Folded dimensions:	29.5" x 3.1" x 28"
	75 x 8 x 71 cm
Weight:	5.7 lb - 2.6 kg
Color:	Black

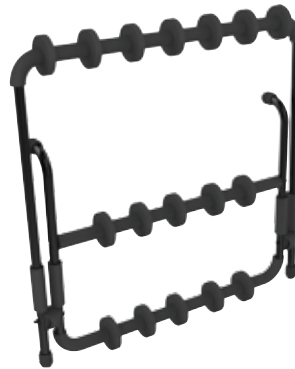

GS/460 MULTIPLE UNIVERSAL GUITAR STAND

- Designed to hold up to 6 acoustic or 6 electric/bass guitars or a combination of electric and acoustic instruments
- Solidly constructed with high-grade steel to ensure a stable base for supporting the heaviest guitars firmly in place
- Padded backrest and base are covered with special foam cushioning that provides a soft but safe support for the guitars and protects them from damages
- Easily width-adjustable rubberized partitions located on base and guitar neck holders protect guitars from damages
- One-piece design for easy and rapid setup in perfect open position without need for tools
- Collapsible backrest allows to quickly fold the stand down to a compact, lightweight, space-saving size for easy storage and convenient portability
- Equipped with casters (two of which locking casters) for easy mobility
- Ideal for use on stage, in studios or at home, but also great for store displays and trade shows
- Can be easily expanded to accommodate more guitars by adding the GS460EXT optional expansion kit

GS/460

- Multiple Universal Guitar Stand

Set-up depth:	17" - 43.2 cm
Set-up width:	42.2" - 107.3 cm
Set-up height:	24.4" - 62 cm
Folded dimensions:	42.2" x 7.5" x 26.4" 107.3 x 19 x 67 cm
Weight:	10.44 lb - 4.7 kg
Color:	Black

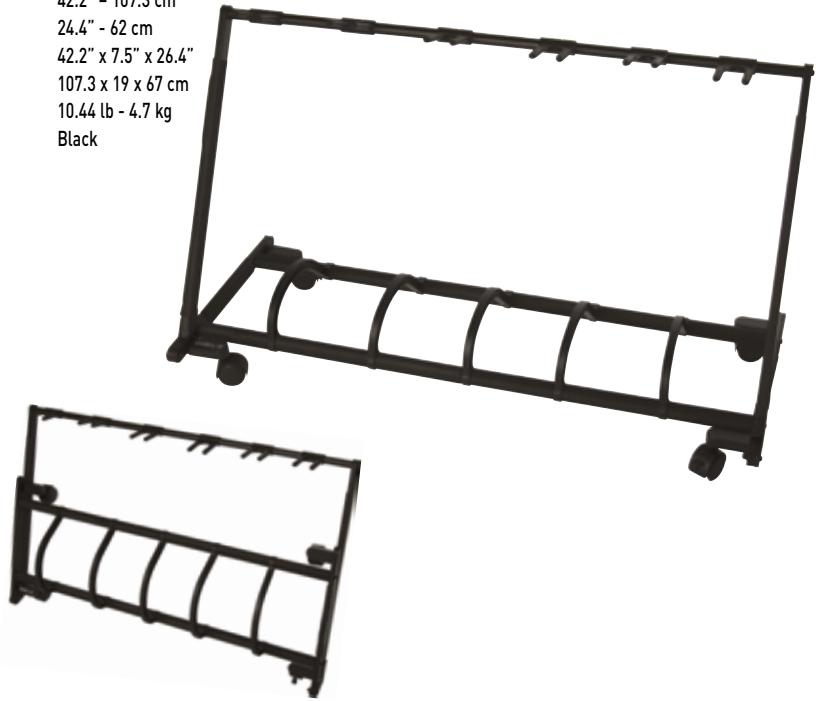

GS/460EXT

Color: Black

- Optional expansion kit for GS/460 Multiple Universal Guitar Stand
- Includes one rubberized base partition and one guitar neck holder
- Required to add one extra guitar to your stand



Guitars Stands

“CLASSIC” SERIES WALL-MOUNTED GUITAR HANGERS

- Safe, space-saving way to hold and display guitars
- Solid all-steel construction
- Hanger swivels to accommodate all headstock shapes
- Soft, rubber cushioning protects guitar neck
- Supplied with all mounting hardware
- Available in black baked-on enamel finish



GS/402

- Guitar Wall Hanger with Oval Contour
- Designed to insert guitar in sideways and turn

Depth (from wall to inside of holder):	3.6" - 9 cm
Total depth:	6.3" - 16 cm
Width:	3.5" - 9 cm
Diameter of mounting plate:	3.3" - 8.5 cm
Weight capacity (secured directly to wall stud):	25 lb - 12.5 kg
Weight:	0.6 lb - 0.3 kg
Color:	Black



GS/403

- Guitar Wall Hanger with Raised Front Forks
- Designed to lift guitar over front forks

Depth (from wall to inside of holder):	3.6" - 9 cm
Total depth:	6.3" - 16 cm
Width:	3.5" - 9 cm
Diameter of mounting plate:	3.3" - 8.5 cm
Weight capacity (secured directly to wall stud):	25 lb - 12.5 kg
Weight:	0.6 lb - 0.3 kg
Color:	Black



GS/454

- Guitar wall hanger with raised front forks and long brace
- 180° rotating forks can be adjusted either right-angle or left-angle from wall

Depth (from wall to inside of holder):	7.7" - 19.5 cm
Total depth:	11.2" - 28.5 cm
Width:	3.5" - 9 cm
Diameter of mounting plate:	3.3" - 8.5 cm
Weight capacity (secured directly to wall stud):	25 lb - 12.5 kg
Weight:	1 lb - 0.45 kg
Color:	Black



GS/454L

- Guitar wall hanger with raised front forks and extra long brace
- 180° rotating forks can be adjusted either right-angle or left-angle from wall

Depth (from wall to inside of holder):	9.6" - 24.5 cm
Total depth:	13" - 33 cm
Width:	3.5" - 9 cm
Diameter of mounting plate:	3.3" - 8.5 cm
Weight capacity (secured directly to wall stud):	25 lb - 12.5 kg
Weight:	1.2 lb - 0.55 kg
Color:	Black

GS/410

- Acoustic Guitar Wall Hanger

Depth (from wall to inside of holder):	3" - 7.5 cm
Total depth:	8.5" - 21.5 cm
Width:	23.2" - 59 cm
Diameter of mounting plate:	3.3" - 8.5 cm
Cradle depth opening:	5.1" - 13 cm
Weight capacity:	25 lb - 12.5 kg
Weight:	3.3 lb - 1.5 kg
Color:	Black



GS/413

- Electric Guitar Wall Hanger

Depth (from wall to inside of holder):	3" - 7.5 cm
Total depth:	6.3" - 16 cm
Width:	23.2" - 59 cm
Diameter of mounting plate:	3.3" - 8.5 cm
Cradle depth opening:	2" - 5 cm
Weight capacity:	25 lb - 12.5 kg
Weight:	3.3 lb - 1.5 kg
Color:	Black



GUITAR WALL-MOUNTS WITH NEW PATENTED SELF-LOCKING YOKE DESIGN

- Quik Lok introduces a new series of guitar wall-mounts incorporating an ingenious device that allows for a secure and space-saving way to hold and display any size electric/acoustic guitar and bass.
- When the guitar is placed into the stand yoke, the instrument's weight will automatically drive the lateral safety barriers incorporated in the yoke to engage. The safety barriers turn down to lock the guitar neck securely in place, preventing the instrument from accidentally falling off the wall. When the guitar is lifted from the stand the security barriers will simultaneously turn back to their original position to free the instrument.
- Durable, smooth velveteen foam padding on yoke protects guitars from scratches and will not mar finish.
- Hanger swivels to accommodate all headstock shapes



GS/701

- Guitar Wall-Mount with self-locking yoke
- Supplied with all mounting hardware

Depth (wall to inside of holder):	4.33" - 11 cm
Total depth:	6.1" - 15.5 cm
Width:	4.33" - 11 cm
Diameter of mounting plate:	3.3" - 8.5 cm
Yoke inner width:	0.20" - 53 mm
Weight capacity:	25 lb - 12.5 kg
Weight:	0.8 lb - 0.36 kg
Color:	Black



GS/701L

- Guitar Wall-Mount with self-locking yoke and long brace
- Supplied with all mounting hardware

Depth (wall to inside of holder):	10.23" - 26 cm
Total depth:	12" - 30.5 cm
Width:	4.33" - 11 cm
Diameter of mounting plate:	3.94" - 10 cm
Yoke inner width:	0.20" - 53 mm
Weight capacity:	25 lb - 12.5 kg
Weight:	1.18 lb - 0.53 kg
Color:	Black



GS/701XL

- Guitar Wall-Mount with self-locking yoke and extra long brace
- Supplied with all mounting hardware

Depth (wall to inside of holder):	12.2" - 31 cm
Total depth:	13.97" - 35.5 cm
Width:	4.33" - 11 cm
Diameter of mounting plate:	3.94" - 10 cm
Yoke inner width:	0.20" - 53 mm
Weight capacity:	25 lb - 12.5 kg
Weight:	1.2 lb - 0.54 kg
Color:	Black





ORCHESTRA
INSTRUMENT STANDS



Orchestra Instrument Stands

“WI” SERIES BRASS & WOODWIND STANDS



WI/996

- Flute / Clarinet Stand
- Compact, pocket-sized, yet sturdy stand will accommodate flute/clarinet instruments comfortably and securely
- The solid, all-metal construction, tripod base provides maximum stability for the instrument
- Soft, non-scratch, plastic injection moulded peg protects instrument's finish
- Unique design allows to instantly fold down the stand, detach the peg and store it within the base, for an extremely compact and handy size, easy to stow and carry around

Diameter of leg spread:	11.8" - 30 cm
Set-up height:	9.4" - 24 cm
Folded size:	2.1" x 2.4" x 10" 5.4 x 6 x 25.5 cm
Peg height:	4.7" - 12 cm
Peg diameter:	0.63" - 16 mm
Weight:	0.62 lb - 0.28 kg
Color:	Black



WI/994

- Trumpet / Cornet Stand
- Compact trumpet/cornet stand with height adjustable spring cushioned bell cup.
- The solid, all-metal construction, tripod base provides maximum stability for the instrument
- Soft, non-scratch, plastic injection moulded bell cup protects instrument's finish
- Unique base design allows to instantly fold down the stand to a compact and handy size, easy to store and carry around
- Available in scratch-resistant, non-reflective, black enamel finish

Diameter of leg spread:	20.5" - 52 cm
Stand fixed height:	15.5" - 39.5 cm
Bell cup height range:	7.1" to 10.4" 18 to 26.5 cm
Folded size:	3.7" x 3.7" x 17.7" 9.5 x 9.5 x 45 cm
Weight:	1.62 lb - 0.73 kg
Color:	Black



WI/993

- Trombone Stand
- Stylish, sturdy trombone stand with height adjustable spring cushioned bell cup
- The solid, all-metal construction, tripod base provides maximum stability for the instrument
- Soft, non-scratch, plastic injection moulded bell cup protects instrument's finish
- Unique base design allows to instantly fold down the stand to a compact and handy size, easy to store and carry around
- Available in scratch-resistant, non-reflective, black enamel finish

Diameter of leg spread:	28.3" - 72 cm
Stand height adjustability:	27.5" to 41.7" 70 to 106 cm
Bell cup height range:	22.4" to 36.6" 57 to 93 cm
Folded size:	3.7"x3.7"x40.5" 9.5x9.5x103 cm
Weight:	3.28 lb - 1.48 kg
Color:	Black

WI/990

- Alto / Tenor Saxophone Stand
- Sturdy "A"-shaped base ensures a stable, positive support for Alto and Tenor Saxophones
- Height adjustable yoke and backrest allow to easily and perfectly adapt to instrument's size and contour
- All instrument contact parts are covered with soft, non-marring velveteen foam coating that will hold instrument firmly in place, carefully preserving its finish
- Optional WI992 peg for Flute/Clarinet is available to accommodate more instruments on either side of the stand
- Folds compactly for easy transport and storage
- Solid steel construction, available in scratch-resistant, non-reflective, black enamel finish

Height:	20" - 51 cm
Set-up width:	11.4" - 29 cm
Set-up height range:	16.1" to 20.5"
	41 to 52 cm
Folded size:	11.2" x 6.5" x 16.5"
	28.5 x 16.5 x 42 cm
Weight:	3.1 lb - 1.4 kg
Color:	Black



WI/990 saxophone stand shown complete with WI/992 optional flute/clarinet peg

WI/992

- Flute / Clarinet Peg
- Optional Flute/Clarinet peg, for use with WI/990 Alto/Tenor Saxophone Stand
- Can be easily connected to either side of the stand to comfortably accommodate up to two additional flute/clarinet instruments
- Soft, non-scratch, plastic injection moulded peg protects instrument's finish

Peg height:	4.7" - 12 cm
Peg diameter:	0.63" - 16 mm
Weight:	0.62 lb - 0.28 kg
Color:	Black



Orchestra Instrument Stands

“CLASSIC” SERIES BRASS & WOODWIND STANDS



SF-C/1

- Flute / Clarinet / Soprano Sax peg

Height: 7.5" - 19 cm
Base Diameter: 5.2" - 13 cm
Weight: 2.5 lb - 1.15 kg
Color: Black



ST-C/1

- Trumpet / Cornet stand

Height adjustability: 7.9" to 15.7"
20 to 40 cm
Diameter of leg spread: 11.77" - 30 cm
Weight: 1.5 lb - 0.7 kg
Color: Black



STB/1

- Trombone stand

Height adjustability: 29.1" to 43.3"
74 to 110 cm
Diameter of leg spread: 18" - 46 cm
Weight: 2.9 lb - 1.3 kg
Color: Black

SSA-T/1

- Alto / Tenor Sax stand

Height: 20" - 51 cm
 Diameter of leg spread: 15.7" - 40 cm
 Weight: 2.9 lb - 1.3 kg
 Color: Black



SSA-T/10

- Alto / Tenor Sax stand

Height adjustability: 34.2" to 49.6"
 87 to 126 cm
 Diameter of leg spread: 22.7" - 58 cm
 Weight: 1.5 lb - 0.7 kg
 Color: Black



SSB/1

- Baritone Sax stand

Height adjustability: 31.1" to 33.9"
 79 to 86 cm
 Diameter of leg spread: 23.55" - 60 cm
 Weight: 2.5 lb - 1.15 kg
 Color: Black



Orchestra Instrument Stands



SSA+FC/1

- Alto / Tenor Sax stand with 1 peg for Flute / Clarinet / Soprano Sax

Height: 20" - 51 cm
Diameter of leg spread: 15.7" - 40 cm
Weight: 2.2 lb - 1 kg
Color: Black



SSA-T+FC/2

- Alto / Tenor Sax stand with 2 pegs for Flute / Clarinet / Soprano Sax

Height: 20" - 51 cm
Diameter of leg spread: 15.7" - 40 cm
Weight: 2.4 lb - 1.1 kg
Color: Black



SSA-T+FC/4

- Double Alto / Tenor Sax stand with 2 pegs for Flute / Clarinet / Soprano Sax

Height: 15.7" - 40 cm
Weight: 4.4 lb - 2 kg
Color: Black

MULTI-FUNCTION
STANDS



Multi Function Stands

WS/640 COMPACT, HEAVY DUTY MULTI-FUNCTION "T" STAND

- The WS/640 is an extremely versatile stand, designed by Quik Lok for multiple applications.
- Great for small live mixers from 18" to 42" (46 to 107 cm) wide, this compact stand is also perfect for speaker cabinets up to 29" (74 cm) wide.
- Ideal solution for securely holding DJ coffi ns, CD rack systems, CD/Record cases and rack cases.
- All four legs are independently height adjustable and each can be swung into position to conform to the size and shape of your equipment.
- Solid rubber rest pads hold speaker equipment firmly in place.
- 8 different height adjustment positions are easily achievable by means of the new Quik Lok spring-loaded security knob. Just pull the knob and set to the desired height, then release and fasten.
- Tilt-angle adjustments can be made by raising back legs.
- Simply swing legs back and the stand folds down to convenient "T" for easy transport.
- Easily expandable to fit musicians' needs by adding any of the available QUIK-LOK accessories.



WS/640

- Compact, heavy duty multi-function "T" stand

Height positions (8):	24.25" to 32.5" 61.6 to 81.3 cm
Width range:	17" to 26" 43.2 to 66 cm
Depth range:	14" to 17.5" 35.6 to 44.5 cm
Frame tubing size:	30 x 30 mm
Weight Capacity:	300 lb - 135 kg
Weight:	13.1 lb - 5.9 kg
Color:	Black

Options: WS/551, WS/552, WS/651, QLX/4*, QLX/5*, IPS/13*, LPH/X*

* Note: can be used only in combination with WS/651 accessory clamp



8 different height adjustment positions are easily achievable by means of the new Quik Lok spring-loaded security knob. Just pull the knob and set to the desired height, then release and fasten.



WS/650 LARGE, HEAVY DUTY MULTI-FUNCTION "T" STAND

- The WS/650 is an extremely versatile stand, designed by Quik Lok for countless applications.
- Ideal for speaker cabinets from 30" to 48" wide (76 to 122 cm), it's also capable of holding the heaviest of keyboards safely and securely.
- Great for large live mixers from 30" to 60" wide (76 to 152 cm), the WS/650 is also perfect for holding DJ coffins, CD rack systems, CD/Record cases and rack cases.
- All four legs are independently height adjustable and each can be swung into position to conform to the size and shape of your equipment.
- Solid rubber rest pads hold speaker equipment firmly in place.
- 8 different height adjustment positions are easily achievable by means of the new Quik Lok spring-loaded security knob. Just pull the knob and set to the desired height, then release and fasten.
- Tilt-angle adjustments can be made by raising back legs.
- Simply swing legs back and the stand folds down to convenient "T" for easy transport.
- Easily expandable to fit musicians' needs by adding any of the available QUIK-LOK accessories.



WS/650

- Large, heavy duty multi-function "T" stand

Height positions (8):	24.25" to 32.5" 61.6 to 81.3 cm
Usable width range:	29.2" to 46.4" 74 to 118 cm
Usable depth range:	17.3" to 27.4" 44 to 69.5 cm
Folded width:	29.2" - 74 cm
Folded height:	24.6" - 62.5 cm
Frame tubing size:	30 x 30 mm
Weight Capacity:	250 lb - 113.1 kg
Weight:	18 lb - 8.1 kg
Color:	Black

Options: WS/551, WS/552, WS/561, WS/562, WS/651, Z/714*, Z/727*, Z/729*, Z/733*, QLX/4**, QLX/5**, IPS/13**, LPH/X**

* Note: can be used only in combination with WS/562 crossbar

** Note: can be used only in combination with WS/651 accessory clamp or Z/727 add-on tiers



8 different height adjustment positions are easily achievable by means of the new Quik Lok spring-loaded security knob. Just pull the knob and set to the desired height, then release and fasten.

Multi Function Stands

WS/550 HEAVY DUTY "T" STAND FOR MOBILE DJ AND PRO AUDIO APPLICATIONS

- Perfect for holding DJ coffins, CD rack systems, CD/record cases and rack cases
- 8 different height adjustment positions
- Solid rubber rest pads hold cases firmly in place
- Fold down to convenient "T" for easy transport

WS/550

- Large, heavy duty multi-function "T" stand

Height positions (8):	24.25" to 32.5" 61.6 to 81.3 cm
Usable width range:	29.2" to 46.4" 74 to 118 cm
Usable depth range:	17.3" to 27.4" 44 to 69.5 cm
Folded width:	29.2" - 74 cm
Folded height:	24.6" - 62.5 cm
Frame tubing size:	30 x 30 mm
Weight Capacity:	250 lb - 113.1 kg
Weight:	18 lb - 8.1 kg
Color:	Black

Options: WS/551, WS/552, WS/561, WS/562, WS/651, Z/714*, Z/727*, Z/729*, Z/730*, Z/733*, QLX/4**, QLX/5**, IPS/11**, IPS/13**, LPH/X**

* Note: can be used only in combination with WS/562 crossbar

** Note: can be used only in combination with WS/651 accessory clamp or Z/727 add-on tiers

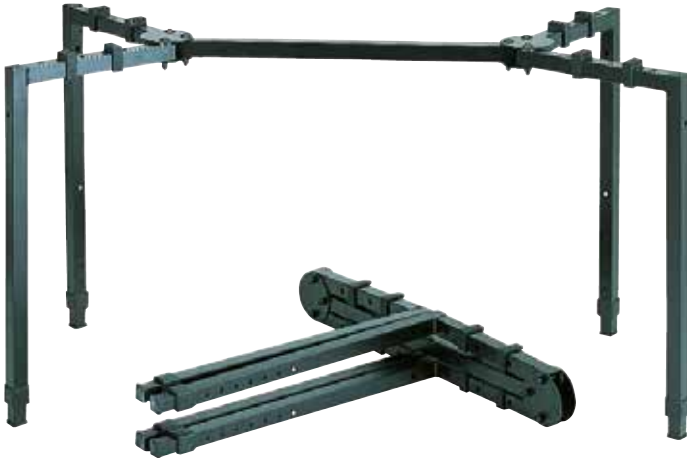

WS/550 DJ coffin stand shown complete with WS/562 accessory bar and Z/733 laptop holder

DJ/233 PERFORMANCE WORKSTATION STRUCTURE FOR DJs

- Quik-Lok introduces the DJ/233 Performance Workstation Structure, a perfect blend of form, functionality and lightweight portability, designed to fit the needs of today's DJs and musicians on the road.
- Ideal solution for most DJ setups, the DJ/233 will accommodate complete DJ systems, DJ controllers, USB/ CD Media Players, DJ mixers, turntables and all sorts of DJ equipment.
- Extremely versatile stand, it also proves very useful for countless other applications. Great for holding DJ cof-fins, CD rack systems, CD/Record cases and rack cases, the DJ/233 is also perfect for drum machines, small size live mixers, and will hold the heaviest of keyboards safely and securely.
- Solid steel construction provides maximum sturdiness and ensures excellent structural support.
- The top shelf is made of perforated sheet metal to ensure optimum ventilation to your gear, and features reinforced steel bracing for added strength.
- 4 different height adjustment positions are easily achievable by simply adjusting the locking telescopic side legs.
- Form and function are combined in a stand that literally folds flat in seconds to a compact transportable size. Simply turn the top shelf around, swing legs back against it, and the stand folds down flat instantly, ready to be stored or carried away using its own built-in handle.
- Easily expandable by adding the optional LPH/T laptop holder or the IPS/16 universal tablet holder.



DJ/233

- Performance Workstation Structure for DJs



Simply turn the top shelf around, swing legs back against it, and the stand folds down flat instantly, ready to be stored or carried away using its own built-in handle.

Height positions (4):	25.2" - 29.5" - 33.8" - 38.2" 64 - 75 - 86 - 97 cm
Platform width:	39.37" - 100 cm
Platform depth:	19.3" - 49 cm
Folded dimensions:	39.4" x 3.9" x 25" 100 x 10 x 63.5 cm
Folded height:	24.6" - 62.5 cm
Weight Capacity:	200 lb - 90 kg
Weight:	27.7 lb - 12.5 kg
Color:	Black

Options: LPH/T, IPS/16



Easily expandable by adding the optional LPH/T laptop holder or the IPS/16 universal tablet holder.



Multi Function Stands

LPH/005 TABLETOP UNIVERSAL LAPTOP HOLDER FOR USE ON STAGE, PRODUCTION STUDIOS AND MULTI-MEDIA WORKSTATIONS

- Clever, safe and practical design allows musicians, DJs and laptop-based performers to integrate their laptop with existing furniture, raising it above all the gear positioned on their workstation.
- Rugged, all-steel construction, will stand alone on any flat surface and hold virtually any size laptop firmly and securely in place, without interfering with dock connector, speaker, headphone jack, on/off and volume buttons.
- No-wobble, lightweight steel platform is designed with safety raised lips, non-slip rubber pads and cooling slots to ensure max ventilation to your laptop.
- The platform can sit flat at a 13.2" fixed height position (33.5 cm), but can also be very quickly angled at two preset tilt positions.
- Lightweight and portable design, folds up in a snap in one piece for easy storage and convenient travel.



LPH/005

- Tabletop universal laptop holder for use on stage, production studios and multi-media workstations

Platform height position:	13.2" - 33.5 cm
Platform width:	11.8" - 30 cm
Platform depth:	11.8" - 30 cm
Folded dimensions:	13.4" x 11.8" x 3.2"
	34 x 30 x 8 cm
Weight capacity:	33 lb - 15 kg
Weight:	4.4 lb - 2 kg
Color:	Black



The platform can sit flat at a 13.2" fixed height position (33.5 cm), but can also be very quickly angled at two preset tilt positions.



Lightweight and portable design, folds up in a snap in one piece for easy storage and convenient travel.



LPH/004

- Free-standing tripod laptop holder.
- All-steel construction.
- Can accommodate virtually any size laptop. Four stoppers, adjustable in width and depth, will securely anchor any size laptop, without interfering with input/output ports, expansion slots, cd-rw/dvd drivers, A/C adapter sockets placed on either side of the laptop.
- The laptop tray is height and tilt adjustable, and swivels at 360° to allow for ideal positioning of the laptop.
- Equipped with pull-out mouse tray, that can be positioned on either the left or right side of the laptop, and is retractable for easy storage and transport.

Height adjustment:	from 29.5" to 50.8" from 75 to 129 cm
Laptop tray dimensions:	10" x 10" 25 x 25 cm
Mouse tray dimensions:	5.3" x 5.3" 13.5 x 13.5 cm
Laptop stoppers width range:	from 10.2" to 16.5" from 26 to 42 cm
Laptop stoppers depth range:	from 10.2" to 16.5" from 26 to 42 cm
Weight:	9.8 lb - 4.4 kg
Color:	Black



Details of LPH/004 pull-out, tilt-adjustable mouse tray



Details of LPH/004 laptop clamping device

Multi Function Stands

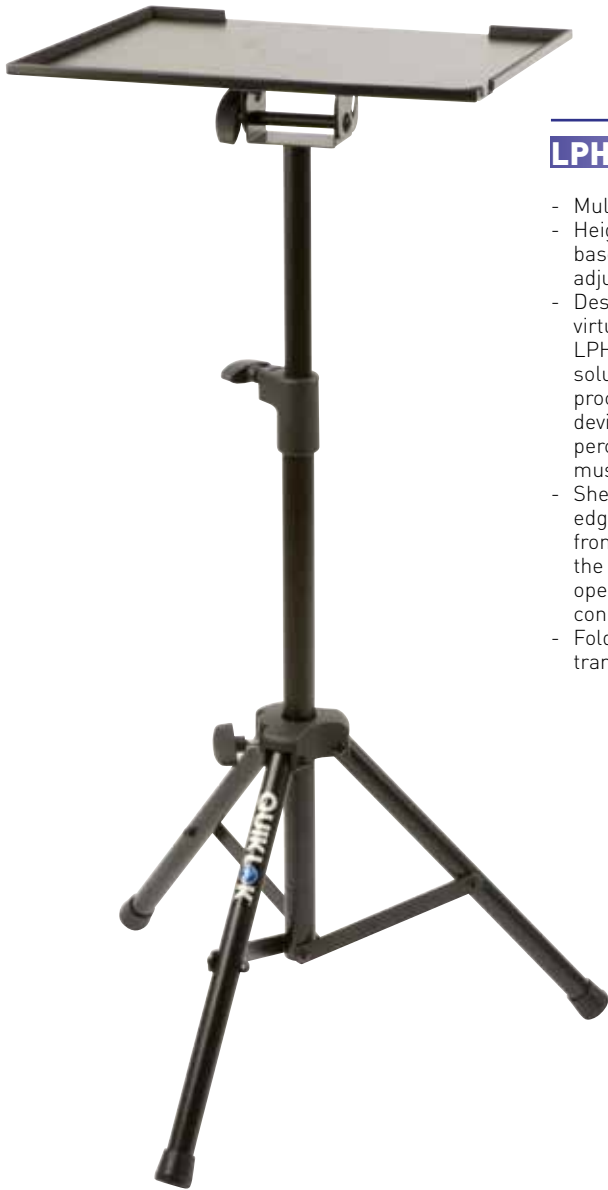

LPH/001

- Multi-Function Tripod Stand
- Height-adjustable tripod base stand incorporating tilt-adjustable metal shelf.
- Designed to securely support virtually any size laptop, the LPH001 is also the ideal solution for holding expanders, processors, mid data input devices, small mixers and percussion instruments, sheet music and songbooks.
- Shelf is designed with raised edges to prevent instruments from accidentally falling off the stand, with a center flange opening to facilitate cable connections.
- Folds flat for easy storage and transport

Shelf width:	15.3" – 39 cm
Shelf depth:	12.2" – 31 cm
Set-up height range:	from 32.3" to 52" from 82 to 132 cm
Weight capacity:	33.3 lb – 15 kg
Weight:	9.1 lb – 4.1 kg
Color:	Black



LPH/1

- Add-on laptop holder for studios and multi-media workstations.
- Can be securely anchored to any table top surface up to 45 mm thick.
- Can accommodate virtually any size laptop. Four stoppers, adjustable in width and depth, will securely anchor any size laptop, without interfering with input/output ports, expansion slots, cd-rw/dvd drivers, A/C adapter sockets placed on either side of the laptop.
- The laptop tray is height and tilt adjustable, and swivels at 360° to allow for ideal positioning of laptop.
- Pull-out mouse tray can be positioned on either the left or right side of the laptop, and is retractable for easy storage and transport.

Height adjustment*:	from 10.2" to 14.5" from 26 to 37 cm
Laptop tray dimensions:	10" x 10" 25 x 25 cm
Mouse tray dimensions:	5.3" x 5.3" 13.5 x 13.5 cm
Laptop stoppers width range:	from 10.2" to 16.5" from 26 to 42 cm
Laptop stoppers depth range:	from 10.2" to 16.5" from 26 to 42 cm
Clamp opening.	1.77" - 4.5 cm
Color:	Black

*Measured from table top to bottom of laptop tray



IPS/16

- Add-on universal tablet holder for studios and multi-media workstations.
- Can be securely anchored to any table top surface up to 72 mm thick (2.83") by means of its tightening clamp, but can also be connected to any stand with round tubing diameter of up to 50 mm (1.96").
- Clever, safe and practical design allows musicians to integrate their tablet with existing furniture, for use on stage, production studios, in the rehearsal room or at home.
- Will accommodate virtually any size tablet having side measurements ranging from 111 mm to 301 mm (4.37" to 11.85") and depth ranging from 6.9 mm to 18.7 mm (0.27" to 0.73").
- Flexible yet rugged rubberized plastic stoppers will hold the tablet firmly and securely in place, without interfering with dock connector, speaker, headphone jack, on/off and volume buttons.
- No-wobble, lightweight aluminium plate is designed to ensure full tilt and rotational adjustability, and to switch rapidly from the vertical to the horizontal viewing mode without slipping, for ideal positioning of your tablet.

Weight capacity:	33 lb - 15 kg
Color:	Titanium or Black



Details of IPS/16 tightening clamp device



Multi Function Stands

IPS/12 UNIVERSAL TABLET HOLDER

- Clever, safe and practical design allows musicians to integrate their tablet with existing microphone and sheet music stands, for use on stage, production studios, in the rehearsal room or at home.
- Will accommodate virtually any size tablet having side measurements ranging from 111 mm to 301 mm (4.37" to 11.85") and depth ranging from 6.9 mm to 18.7 mm (0.27" to 0.73").
- Flexible yet rugged rubberized plastic stoppers will hold the tablet firmly and securely in place, without interfering with dock connector, speaker, headphone jack, on/off and volume buttons.
- No-wobble, lightweight aluminium plate is designed to ensure full tilt and rotational adjustability, and to switch rapidly from the vertical to the horizontal viewing mode without slipping, for ideal positioning of your tablet.
- The holder can be fastened directly on to any 3/8" standard microphone stand thread connection. A slim yet sturdy steel bracket (included) allows to mount the tablet holder sideways to the vertical pole of any microphone or sheet music stand with diameter ranging from 14 to 30 mm (0.55" to 11.8").

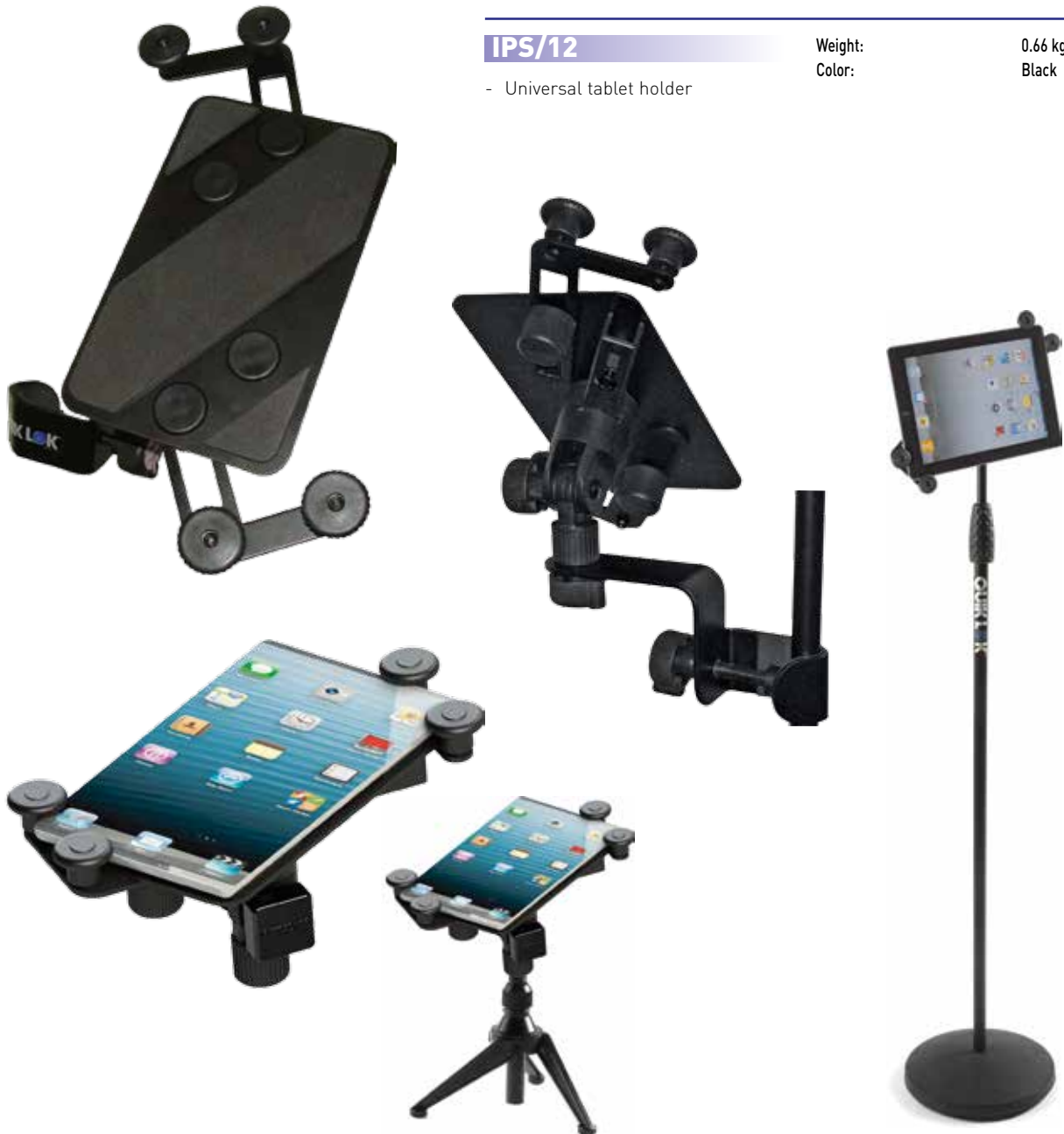

IPS/12

- Universal tablet holder

Weight:

0.66 kg (1.47 lb)

Color:

Black

DSP/590 PORTABLE FLOOR STAND FOR LCD/PLASMA TVs 36" TO 55" WIDE

- With a blend of style and functionality, the DSP/590 combines a universal flat screen mounting system with a durable, portable base that is perfect for commercial use. Ideal solution for broadcasting, presentations, conference rooms, trade shows, hospitality centers, hotel lobbies, airports, shopping malls, rentals, staging, etc.
- The versatile, universal mounting system can be positioned at 5 different height positions, ranging from 49.2" to 70.8" (125 to 180 cm), with a tilt angle adjustment of (+/-) 15° for optimum viewing.
- Sturdy four-legged base, equipped with heavy-duty, rubber thread, steel casters (all locking) for easy mobility.
- The DSP/590 system includes a center metal shelf to accommodate audio/video components.
- The support column, manufactured using high-strength alloy steel, features cable conduits to hide A/C power cords, speaker wires, and audio/video cables from view, creating a much neater and elegant appearance.



DSP/590

- Portable floor stand for LCD/ Plasma TVs 36" to 55" wide

Overall dimensions (WxHxD): 36.2" x 79.1" x 28.5"
92.1 x 201 x 72.5 cm
Weight capacity: 133 lb - 60 kg
Color: Matte Black



DSP/390

- Universal Mount for LED flat screens, LCD displays and video monitors up to 40", built with VESA bolt pattern mounting standards.
- Designed for mounting of flat screen TV's on a floor stand, it easily mounts over the top of any speaker/lighting stand built using 35 mm diameter round tubing, and securely connects to it by means of a practical clamping device.
- Mounting plate features up-and down tilt adjustments (0°/+10°) and full side-to-side adjustment (360°).
- Manufactured using high-strength steel sheet metal.
- Includes all VESA hardware for fast and simple installation.

Plate dimensions: 9" x 9"
23 x 23 cm
VESA compliant: Including VESA
75x75mm
100x100mm
100 x 200mm
200x200mm
Weight: 3.66 lb - 1.65 kg
Weight capacity: 66.6 lb - 30 kg
Color: Black



Multi Function Stands



AMPLIFIER STANDS



Amplifier Stands

TILT ADJUSTABLE LOW STANDS FOR GUITAR, BASS, KEYBOARD AMPS & COMBOS

- Tilt-back design adjusts for exact positioning from the floor
- Straight back brace will not interfere with open-back cabinets
- "Dino-bite" locking disc system provides secure, non-slip adjustments
- All-steel, arc-welded construction
- Fold flat for compact portability
- Soft, rubber rest pads hold amps firmly in place
- Adjustable leveling foot compensates for uneven floors



BS/313

- Single-Brace, Low Profile Stand for small Amps & Combos



Side to side width:	10" - 25.4 cm
Front to back depth range:	11.8" to 15" 30 to 38 cm
Front tier height range:	8.25" to 11" 21 to 28 cm
Back tier height range:	11.4" to 18.6" 29 to 47.2 cm
Brace tube size:	20 mm x 15 mm
Tier tube diameter:	28 mm
Weight capacity:	75 lb - 33.9 kg
Weight:	3.7 lb - 1.7 kg
Color:	Black



BS/317

- Double-Brace, Low Profile Stand for Large Amps and Combos



Height adjustment range:	
Front tier:	8.25" to 11" 21 to 28 cm
Back tier:	11.4" to 18.6" 29 to 47.2 cm
Width:	19.3" - 49 cm
Folded height:	22" - 56 cm
Frame tube size:	20 x 15 mm
Tier tube size:	28 mm
Weight capacity:	100 lb - 45.2 kg
Weight:	6.6 lb - 3 kg
Color:	Black

BS/620

- Large amp "X" stand with adjustable back tier
- Adjusts so that the back tier rests on the back panel of open back guitar amps/combos and does not enter the empty space
- This unique design assures no damage to tubes or electronics

Front tier height range:	20.3" to 22.6" 51.6 to 57.5 cm
Back tier height range:	27.9" to 33.2" 70.8 to 84.3 cm
Depth range:	15.5" to 32" 39.5 to 81.5 cm
Width:	19.7" - 50 cm
Folded height:	33.8" - 86 cm
Weight capacity:	150 lb - 67.9 kg
Weight:	9.5 lb - 4.3 kg
Color:	Black



QL/640

- Heavy-duty, fully adjustable amp stand
- Securely holds small amps and combos with up to two 12" speakers
- Full-circle tilt adjustable amp platform allows for exact amp positioning
- 5 height adjustment positions with spring-loaded locking pin
- Back leg folds forward for easy portability

Top platform dimensions:	
Height:	14" - 35.5 cm
Width:	16.1" - 41 cm
Depth:	4.7" - 12 cm
Height adjustment range*:	12.4" to 24.8" 31.5 to 63 cm
Depth range:	15.5" to 23.7" 9.3 to 60.2 cm
Width:	16.8" - 42.7 cm
Fold-up height:	32.3" - 82 cm
Frame tube size:	30 x 30 mm
Weight Capacity:	60 lb - 27.1 kg
Weight:	13.2 lb - 6 kg
Color:	Black

*(from bottom of cradle to floor)



Amplifier Stands

BS/625 FULLY ADJUSTABLE AMPLIFIER STAND

- This heavy duty, fully adjustable A-frame stand features a dual set of robust, height-adjustable, foldable support arms that ensure maximum versatility of use and allow for a variety of applications.
- The BS625 can be configured to securely hold various sized combo amplifiers, up to two 12" speaker cabinets and cabinet/amp head combinations.
- The tilt-back bottom amp holders are height adjustable to 4 positions, and can safely accommodate large size combo amps or speaker cabinets with up to 2 x 12" speakers.
- The top amp platform, featuring 6 height positions with safety locking pin and tilt adjustability, will securely hold combo amplifiers and amp heads. When positioned horizontally and with folded support arms, the top platform can also become a very suitable accommodation for guitar effects, rack cases or small mixers, leaving enough room for up to a 27.5" (70 cm) high combo amplifier to be placed on the bottom support arms.
- Tilt-back design and height adjustability allow for ideal amp positioning from floor, optimal sound and fine quality listening. Soft, rubber rest pads hold amps firmly in place.
- Folds completely flat for easy portability and storage.

BS/625

- Fully adjustable amplifier stand

Top platform:
Height: 15.6" - 37 cm
Depth: 7.5" - 19 cm
Ground elevation: 21.3" to 30"
54 to 75 cm

Lower platform:
Max Width: 14.8" to 19.7"
37,5 to 50 cm
Depth: 7.5" - 19 cm
Ground elevation: 3.2" to 7.5"
8 to 19 cm

General Dimensions:
Depth: 19.3" / 25.2"
(49 / 64 cm)
Width: 20.3" - 51.5 cm
Gap between platforms: 14.2" to 21.7"
36 to 55 cm

Height (folded): 25.6" - 65 cm
Frame tube size: 30 x 30 mm
Weight Capacity: 88.2 lb - 40 kg
Weight: 14.7 lb - 6.7 kg
Color: Black





The top amp platform, featuring 6 height positions with safety locking pin and tilt adjustability, will securely hold combo amplifiers and amp heads



The tilt-back bottom amp holders are height adjustable to 4 positions, and can safely accommodate large size combo amps or speaker cabinets with up to 2 x 12" speakers



The BS625 can be configured to securely hold various sized combo amplifiers, up to two 12" speaker cabinets and cabinet/amp head combinations.

Amplifier Stands



BS/619

- Portable Amp / Rack Case "X" Stand with Collapsible Telescopic Tiers
- The BS/619 is Quik-Lok's most versatile utility stand
- It can be set to any number of straight or sloped height positions by simply adjusting the locking telescopic tiers
- It can be used to hold guitar, bass or keyboard amps and rack cases up to 180 lb (81 Kg) and folds down to a convenient size of 28" (71 cm) for easy transport

Leg depth:	19.5" - 49.5 cm
Tier depth:	13.75" - 34.9 cm
Folded height:	28" - 71 cm
Weight capacity:	180 lb - 81 kg
Weight:	9.5 lb - 4.3 kg
Upper brace tube size:	25 x 25 mm
Lower brace tube size:	30 x 30 mm
Tier tube size:	30 mm
Color:	Black

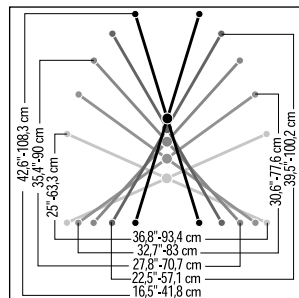

BS/619 Height & width positions



The BS-619 folds down to only 71 cm (28") for convenient storage and transportation

BS/310

- Low-profile, tilt-angled stand for small amps/combos
- Specifically designed to position speakers as close as possible to the floor, with tilt-back angle to ensure optimal sound and fine quality listening.
- Folds completely flat for easy portability and storage.

Height:	12.6" - 32 cm
Base width:	12" - 30.5 cm
Base depth:	15.95" - 40.5 cm
Weight:	4 lb - 1.8 kg
Color:	Black



RACK EQUIPMENT STANDS & RACK ACCESSORIES



Rack Equipment Stands

MODULAR RACK EQUIPMENT STAND SYSTEM

- Quik-Lok's rack equipment system is a unique design that is completely expandable
- Each unit adds 10 rack spaces to the system allowing stackable vertical expansion up to 30 rack spaces
- Solid heavy gauge steel and arc-welded construction
- Securely holds gear up to 18" deep (45.7 cm)
- Open back allows for easy access to cables and connections
- Perfect for recording, broadcast and multimedia applications
- Convenient hand rails and casters allow for easy mobility
- Supplied with rack hardware



RS/656

- Vertical Add-on 10-Space Unit
- Supplied with rack hardware

RS/656 AM

Uses American 10/32 hardware

RS/656 EU

Uses European 6 mm hardware

Height:	18.5" - 47 cm
Width:	21.8" - 55.5 cm
Depth:	17.7" - 45 cm
Weight capacity:	150 lb - 67.5 kg
Weight:	15.5 lb - 7 kg
Color:	Black



RS/655

- 10-Space Base Unit with casters
- Supplied with rack hardware

RS/655 AM

Uses American 10/32 hardware

RS/655 EU

Uses European 6 mm hardware

Height:	24.4" - 62 cm
Width:	21.8" - 55.5 cm
Depth:	17.7" - 45 cm
Weight capacity:	150 lb - 67.5 kg
Weight:	16 lb - 7.2 kg
Color:	Black



RS/10

- 10-Space Table Top Rack Stand for studios or store displays
- Supplied with rack hardware

RS/10 AM

Uses American 10/32 hardware

RS/10 EU

Uses European 6 mm hardware

Height:	21" - 53.5 cm
Width:	20.8" - 52.8 cm
Leg depth:	15" - 38 cm
Frame size:	20 x 20 mm
Weight capacity:	150 lb - 67.9 kg
Weight:	5.3 lb - 2.4 kg
Color:	Black



Rack Equipment Stands

RS/500 SERIES RACK STAND SYSTEM

- The RS/500 series rack stands are more than just places to hold rack equipment. Because the RS/500 series rack stands are completely modular, all kinds of rack configurations are possible.
- This system is perfect for applications where a large number of rack spaces are required. Any configuration can be made to expand vertically or horizontally to fit any type of audio or video environment. RS/500 series stands incorporate perforated side panels.
- The RS/500 series rack stands are manufactured using state-of-the-art, computer-controlled welding and laser cutting machines. This guarantees high quality and a very affordable price.
- Perfect for home and pro recording, broadcast and multimedia applications
- Completely expandable both horizontally and vertically
- Ergonomically designed to allow easy access to all rack equipment
- Open access to cables and connections
- Designed for maximum air ventilation
- Manufactured using computer-welded 14-gauge steel
- Supplied with locking casters and rack hardware



RS/512

- Ergonomical 10-Space rack stand top unit with a 65° angle downward
- Can be easily mounted onto RS/507, RS/510, RS/514 and RS/513 rack base units with a 65° angle downward

RS/512 AM

Uses American 10/32 hardware

RS/512 EU

Uses European 6 mm hardware

Height:	22" - 56 cm
Width:	21.3" - 54 cm
Bottom depth:	19.7" - 50 cm
Top depth:	29.5" - 75 cm
Weight capacity:	100 lb - 45 kg
Color:	Black



RS/514

- Straight 14-Space rack stand add-on unit
- Can be easily mounted onto RS/507, RS/510, and RS/513 rack base units
- Supplied with rack hardware

RS/514 AM

Uses American 10/32 hardware

RS/514 EU

Uses European 6 mm hardware

Height:	24.8" - 63 cm
Width:	21.3" - 54 cm
Depth:	19.7" - 50 cm
Weight capacity:	200 lb - 90.5 kg
Color:	Black



RS/510

- Ergonomical 10-Space rack stand base unit with a 65° angle upward
- Supplied with casters and hardware

RS/510 AM

Uses American 10/32 hardware

RS/510 EU

Uses European 6 mm hardware

Height:	24.6" - 62.5 cm
Width:	21.3" - 54 cm
Top depth:	19.7" - 50 cm
Bottom depth:	29.5" - 75 cm
Weight capacity:	200 lb - 90.5 kg
Color:	Black



Rack Equipment Stands



RS/513

- Straight 14-Space rack stand base unit
- Supplied with casters and hardware

Height:	27.3" - 69.3 cm
Width:	21.3" - 54 cm
Depth:	19.7" - 50 cm
Weight capacity:	200 lb - 90.5 kg
Color:	Black

RS/513 AM

Uses American 10/32 hardware

RS/513 EU

Uses European 6 mm hardware



RS/507

- Straight 7-Space rack stand add-on unit
- Can be easily mounted onto RS/510, RS/514 and RS/513 rack base units
- Supplied with rack hardware

Height:	12.5" - 31.7 cm
Width:	21.3" - 54 cm
Depth:	19.7" - 50 cm
Weight capacity:	200 lb - 90.5 kg
Color:	Black

RS/507 AM

Uses American 10/32 hardware

RS/507 EU

Uses European 6 mm hardware



RS/516

- Perforated metal top shelf
- Optional for RS/507, RS/510, RS/514, and RS/513 rack stands
- Gives your rack stand system a neater appearance and protects your rack gear from dust, while allowing to stack additional equipment on top of it

Width:	21.3" - 54 cm
Depth:	19.7" - 50 cm
Weight capacity:	100 lb - 45 kg
Color:	Black

QUIK-LOK'S LINE OF SUPERIOR QUALITY RACK ACCESSORIES

- Electrostatic black powder-coat finish
- Manufactured using heavy gauge steel
- All rack panels and shelves are rigidly constructed with flanged edges for added strength
- All shelves are supplied with rack hardware

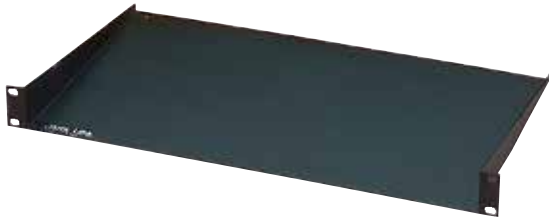

RS/660

- 1-Space Rack Shelf

Surface Height:	1 rack space (1.75" - 4.45 cm)
Surface Width:	17.3" - 44 cm
Surface Depth:	10" - 25.5 cm
Weight capacity:	30 lb - 13.6 kg
Weight:	3.1 lb - 1.4 kg
Color:	Black



RS/673

- 1-Space Universal Rack Shelf
- Designed to securely mount non-rackable equipment through multiple bolt holes located on the shelf

Surface Height:	1 rack space (1.75" - 4.45 cm)
Surface Width:	17.3" - 44 cm
Surface Depth:	9.4" - 24 cm
Weight Capacity:	30 lb - 13.6 kg
Weight:	3.1 lb - 1.4 kg
Color:	Black



RS/668

- 1-Space rack shelf

Surface height:	1 rack space (1.75" - 4.45 cm)
Surface width:	17.3" - 44 cm
Surface depth:	9 rack spaces (16.9" - 43 cm)
Weight capacity:	30 lb - 13.6 kg
Weight:	6 lb - 2.7 kg
Color:	Black

Rack Equipment Stands



View showing RS/668 mounted onto a rack case

RS/669

- 2-Space rack shelf
- Same specifications as RS/668 shelf, with increased rack space

Surface height:	2 rack space (3.5" - 8.9 cm)
Surface width:	17.3" - 44 cm
Surface depth:	9 rack spaces (16.9" - 43 cm)
Weight capacity:	30 lb - 13.6 kg
Weight:	6.9 lb - 3.1 kg
Color:	Black



RS/670

- 2-Space Rack Drawer

Drawer inside Height:	2.8" - 7.3 cm
Drawer inside Width:	15.3" - 39 cm
Drawer inside Depth:	14.5" - 37 cm
Weight capacity:	40 lb - 18.1 kg
Weight:	16.4 lb - 7.4 kg
Color:	Black



RS/671

- 3-Space Rack Drawer

Drawer inside Height:	4.7" - 12 cm
Drawer inside Width:	15.3" - 39 cm
Drawer inside Depth:	14.5" - 37 cm
Weight capacity:	40 lb - 18.1 kg
Weight:	18.8 lb - 8.5 kg
Color:	Black

RS/247

- Fixing Screw for Rack Stands

RS/247 AM

10/32 Allen head rack screw, for use with RS/248 AM and on any standard American Rack Rail

RS/247 EU

M 6x15 Allen type fixing screw, for use with RS/248 EU on any standard European Rack Rail



RS/248

- Captive Nut for Rack Stands

RS/248 AM

10/32 permaplated captive nut for all rack stands using american 10/32 hardware. For use with RS/247 AM screws.

RS/248 EU

M6 zinc plated Steel captive nut for Rack Stands using European hardware. For use with RS/247 EU screws.



RS/249

- Plastic cup washer for use with rack screws RS/247 AM and RS/247 EU



RS/299

- Hide Cover for XLR panel

Height: 1.22" - 3.1 cm
Width: 1.02" - 2.6 cm
Color: Black



RS/245

- 1-Space blank panel with flanged edges

Height: 1 rack space (1.75" - 4.45 cm)
Color: Black



RS/242

- 2-Space blank panel with flanged edges

Height: 2 rack space (3.5" - 8.9 cm)
Color: Black



Rack Equipment Stands



RS/246

- 3-Space blank panel with flanged edges

Height:

3 rack space
(5.25" - 13.35 cm)

Color:

Black



RS/276

- 5-Space blank panel with flanged edges

Height:

5 rack space
(8.6" - 22 cm)

Color:

Black



RS/241

- 1-Space rack ventilation panel with flanged edges

Height:

1 rack space
(1.75" - 4.45 cm)

Color:

Black

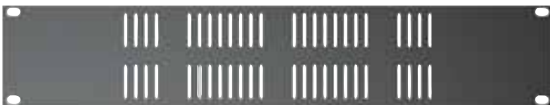

RS/277

- 2-Space rack ventilation panel with flanged edges

Height:

2 rack space
(3.5" - 8.9 cm)

Color:

Black



RS/278

- 3-Space rack ventilation panel for 3 fans with flanged edges

Height:

3 rack space
(5.25" - 13.35 cm)

Color:

Black

RS/281

- 1-Space rack panel with flanged edges with 8 mounting holes for D 6,3 mm Plugs

Height: 1 rack space
(1.75" - 4.45 cm)
Holes diameter: 0.45" - 11.5 mm
Color: Black



RS/289

- 1-Space rack panel with flanged edges with 4 mounting holes for Neutrik XLR

Height: 1 rack space
(1.75" - 4.45 cm)
Holes diameter: 0.94" - 24 mm
Color: Black

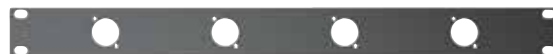

RS/292

- 1-Space rack panel with flanged edges with 8 mounting holes for Neutrik XLR

Height: 1 rack space
(1.75" - 4.45 cm)
Holes diameter: 0.94" - 24 mm
Color: Black



RS/290

- 1-Space rack panel with flanged edges with 6 mounting holes for Neutrik XLR

Height: 1 rack space
(1.75" - 4.45 cm)
Holes diameter: 0.94" - 24 mm
Color: Black



RS/243

- 1-Space rack panel with flanged edges with 12 mounting holes for Neutrik XLR

Height: 1 rack space
(1.75" - 4.45 cm)
Holes diameter: 0.94" - 24 mm
Color: Black



Rack Equipment Stands



RS/293

- 1-Space rack panel with flanged edges with 8 mounting holes for Neutrik XLR, complete with rear lacing bar

Height: 1 rack space (1.75" - 4.45 cm)
Holes diameter: 0.94" - 24 mm
Color: Black

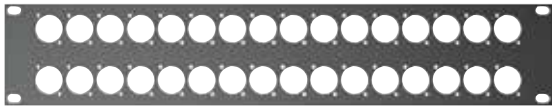

RS/295

- 2-Space rack panel with flanged edges with 32 mounting holes for Neutrik XLR

Height: 2 rack spaces (3.5" - 8.9 cm)
Holes diameter: 0.94" - 24 mm
Color: Black



RS/294

- 1-Space rack panel with flanged edges with 16 mounting holes for Neutrik XLR

Height: 1 rack space (1.75" - 4.45 cm)
Holes diameter: 0.94" - 24 mm
Color: Black

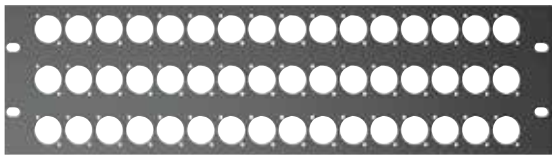

RS/297

- 3-Space rack panel with flanged edges with 48 mounting holes for Neutrik XLR

Height: 3 rack spaces (5.25" - 13.35 cm)
Holes diameter: 0.94" - 24 mm
Color: Black



RS/296

- 2-Space rack panel with flanged edges with 32 mounting holes for Neutrik XLR, complete with rear lacing bar

Height: 2 rack spaces (3.5" - 8.9 cm)
Holes diameter: 0.94" - 24 mm
Color: Black

MIXER STANDS



Mixer Stands

WS/421 HEAVY DUTY, FULLY ADJUSTABLE MIXER/KEYBOARD STRUCTURE

- The WS/421 is an extremely versatile stand, designed for multiple applications.
- Heavy duty construction, the sturdy frame is built to hold the heaviest of keyboards and digital pianos safely and securely.
- Ideal for small live mixers, DJ coffins, recording and audio equipment.
- Height adjustable to 12 different positions up to 37.8" (96 cm), the WS/421 is also width expandable from 25.2" to 39.4" (64 to 100 cm) to conform to the exact size of your equipment.
- Grants maximum leg room for comfortable playing, providing a large open area for placement of floor pedals.
- Folds flat to a very compact size for easy transport and storage.
- Easily expandable to fit musicians' needs by adding any of the available QUIK-LOK accessories.

WS/421

- Portable, heavy duty, width and height adjustable keyboard/mixer stand with foldable legs

Specifications:

Height positions (12):	25.6" to 37.8" 65 to 96 cm
Usable width range:	25.2" to 39.4" 64 to 100 cm
Usable depth:	11.8" - 30 cm
Folded dimensions:	27.9" x 14.6" x 5.3" 71 x 37 x 13.5 cm
Frame tubing size:	30 mm
Weight Capacity:	178 lb - 80 kg
Weight:	18 lb - 8 kg
Color:	Black

Options: WS/422, QLX/4*, QLX/5*, LPH/X*, IPS/13*

* Note: can be used only in combination with WS/422 add-on tiers



WS/421 folds flat and locks rapidly to a compact, transportable size

WS/420

- Portable, Heavy Duty, Height & Width Adjustable Stand With Foldable Legs

Height positions (10):	25.6" to 43.3" 65 to 110 cm
Usable width range:	28.7" to 44.5" 73 to 113 cm
Usable depth:	12.6" - 32 cm
Weight Capacity:	178 lb - 80 kg
Weight:	15.5 lb - 7 kg
Color:	Black



LPH/001

- Multi-Function Tripod Stand
- Height-adjustable tripod base stand incorporating tilt-adjustable metal shelf.
- Designed to securely support virtually any size laptop, the LPH001 is also the ideal solution for holding expanders, processors, mid data input devices, small mixers and percussion instruments, sheet music and songbooks.
- Shelf is designed with raised edges to prevent instruments from accidentally falling off the stand, with a center flange opening to facilitate cable connections.
- Folds flat for easy storage and transport

Shelf width:	15.3" - 39 cm
Shelf depth:	12.2" - 31 cm
Set-up height range:	from 32.3" to 52" from 82 to 132 cm
Weight capacity:	33.3 lb - 15 kg
Weight:	9.1 lb - 4.1 kg
Color:	Black



Mixer Stands

WS/650 LARGE, HEAVY DUTY MULTI-FUNCTION "T" STAND

- The WS/650 is an extremely versatile stand, designed by Quik Lok for countless applications.
- Ideal for speaker cabinets from 30" to 48" wide (76 to 122 cm), it's also capable of holding the heaviest of keyboards safely and securely.
- Great for large live mixers from 30" to 60" wide (76 to 152 cm), the WS/650 is also perfect for holding DJ coffins, CD rack systems, CD/Record cases and rack cases.
- All four legs are independently height adjustable and each can be swung into position to conform to the size and shape of your equipment.
- Solid rubber rest pads hold speaker equipment firmly in place.
- 8 different height adjustment positions are easily achievable by means of the new Quik Lok spring-loaded security knob. Just pull the knob and set to the desired height, then release and fasten.
- Tilt-angle adjustments can be made by raising back legs.
- Simply swing legs back and the stand folds down to convenient "T" for easy transport.
- Easily expandable to fit musicians' needs by adding any of the available QUIK-LOK accessories.

WS/650

- Large, heavy duty multi-function "T" stand

Height positions (8):	24.25" to 32.5" 61.6 to 81.3 cm
Usable width range:	29.2" to 46.4" 74 to 118 cm
Usable depth range:	17.3" to 27.4" 44 to 69.5 cm
Folded width:	29.2" - 74 cm
Folded height:	24.6" - 62.5 cm
Frame tubing size:	30 x 30 mm
Weight Capacity:	250 lb - 113.1 kg
Weight:	18 lb - 8.1 kg
Color:	Black

Options: WS/551, WS/552, WS/561, WS/562, WS/651, Z/727*, Z/729*, Z/733*, QLX/4**, QLX/5**, IPS/13**, LPH/X**

* Note: can be used only in combination with WS/562 crossbar

** Note: can be used only in combination with WS/651 accessory clamp or Z/727 add-on tiers



8 different height adjustment positions are easily achievable by means of the new Quik Lok spring-loaded security knob. Just pull the knob and set to the desired height, then release and fasten.



WS/640 COMPACT, HEAVY DUTY MULTI-FUNCTION "T" STAND

- The WS/640 is an extremely versatile stand, designed by Quik Lok for multiple applications.
- Great for small live mixers from 18" to 42" (46 to 107 cm) wide, this compact stand is also perfect for speaker cabinets up to 29" (74 cm) wide.
- Ideal solution for securely holding DJ coffins, CD rack systems, CD/Record cases and rack cases.
- All four legs are independently height adjustable and each can be swung into position to conform to the size and shape of your equipment.
- Solid rubber rest pads hold speaker equipment firmly in place.
- 8 different height adjustment positions are easily achievable by means of the new Quik Lok spring-loaded security knob. Just pull the knob and set to the desired height, then release and fasten.
- Tilt-angle adjustments can be made by raising back legs.
- Simply swing legs back and the stand folds down to convenient "T" for easy transport.
- Easily expandable to fit musicians' needs by adding any of the available QUIK-LOK accessories.



WS/640

- Compact, heavy duty multi-function "T" stand



Height positions (8):	24.25" to 32.5" 61.6 to 81.3 cm
Width range:	17" to 26" 43.2 to 66 cm
Depth range:	14" to 17.5" 35.6 to 44.5 cm
Frame tubing size:	30 x 30 mm
Weight Capacity:	300 lb - 135 kg
Weight:	13.1 lb - 5.9 kg
Color:	Black

Options: WS/551, WS/552, WS/651, QLX/4*, QLX/5*, IPS/13*, LPH/X*

* Note: can be used only in combination with WS/651 accessory clamp



WS/651

- Accessory clamp for use with WS/550, WS640 & WS650 multi-function "T" stands
- Required to attach to any one of the four legs of these stand models the following accessories:
 - QLX/4 Telescopic mic boom
 - QLX/5 Sheet music holder
 - IPS/13 Universal tablet holder
 - LPH/X Laptop holder.



WS/640 multi-function stand in use with WS/651 accessory clamp and LPH/X laptop holder

Mixer Stands



QL/400

- Fully Adjustable Studio Mixer Stand for Equipment from 14.4" to 21" (36.5 - 53.5 cm) Wide
- Perfect stand for securely holding studio remote units, digital or analog multi-track recorders, mid data input devices and small mixers up to 26" (66 cm) deep
- Ideally suited for home, project, multimedia and professional recording studios
- Width, depth and tilt adjustable steel platform with padded cushions holds equipment firmly and safely in place
- Five wheel, easy roll, injection-molded plastic base with locking casters
- Locking height adjustability allows the user to be sitting or standing

Platform dimensions:

Width range:	14.4" to 21" 36.5 to 53.5 cm
Depth range:	11.8" to 16" 30 to 40.5 cm
Height (side lip):	2" - 5 cm
Tilt angle range:	360
Height positions (5)*:	27.2", 29.7", 32.3", 34.8", 37.4" 69, 75.5, 82, 88.5, 95 cm
Diameter of wheel base:	22.8" - 58 cm
Weight Capacity:	80 lb - 36.2 kg
Weight:	13.8 lb - 6.2 kg
Color	Black

*[measured from platform tilt swivel to floor]



WORKSTATIONS & COMPUTER FURNITURE



Z/630 PROJECT WORKSTATION, AN INTEGRATION OF BEAUTY AND FUNCTIONALITY BY QUIK LOK'S ITALIAN DESIGNERS TEAM

- For the harmonious integration of your human activity within the high-tech world let Quik-Lok help you improve your flow of creative energy
- The Z/630 project workstation with its own 8-space rack, and the Z/612 companion 12-space rack, are the essence of design and functionality
- From the finest wood laminate tops and shelves to the underlying computer-welded 14-gauge steel with powder-coating black finish, these structures add a modern, elegant look to any work environment
- Available with wood laminate tops in both black and cherry finish

Z/630 CY

- Dual level project desk system with 8-space rack holders and contoured cherry wood tops

Main Shell dimensions:

Height from floor:	28.9" - 73.4 cm
Width:	68.68" - 175 cm
Depth:	23.74" - 60.3 cm
Thickness:	18 mm

Top Shelf dimensions:

Height from floor:	39.33" - 100 cm
Width:	78.35" - 199 cm
Depth:	14.71" - 37.5 cm
Thickness:	18 mm

Overall Width:	78.35" - 199 cm
Overall Depth:	45.78" - 116.3 cm
Metal frame colour:	Black

Options: Z/712 BK/CY, LPH/T, TM/109, IPS/16, A/156



View of Z/630 CY project desk system set up for use





View of Z/630 BK project desk system set up for use

Z/630 BK

- Dual level project desk system with 8-space rack holders and contoured black wood tops

Main Shell dimensions:

Height from floor:	28.9" - 73.4 cm
Width:	68.68" - 175 cm
Depth:	23.74" - 60.3 cm
Thickness:	18 mm

Top Shelf dimensions:

Height from floor:	39.33" - 100 cm
Width:	78.35" - 199 cm
Depth:	14.71" - 37.5 cm
Thickness:	18 mm

Overall Width:	78.35" - 199 cm
Overall Depth:	45.78" - 116.3 cm
Metal frame colour:	Black

Options: Z/712 BK/CY, LPH/T, TM/109, IPS/16, A/156



Details of Z/630 base equipped with hidden casters for easy mobility and stabilizing plastic feet to compensate for uneven floors

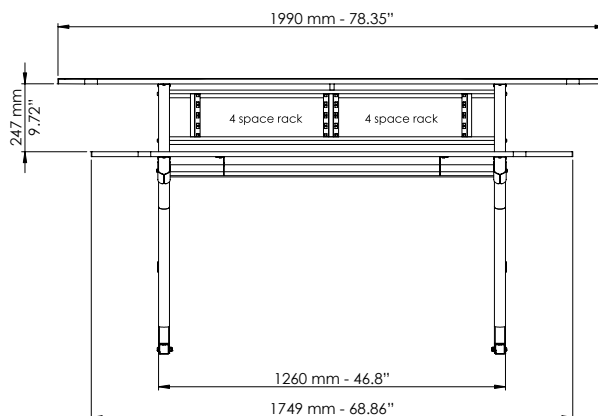
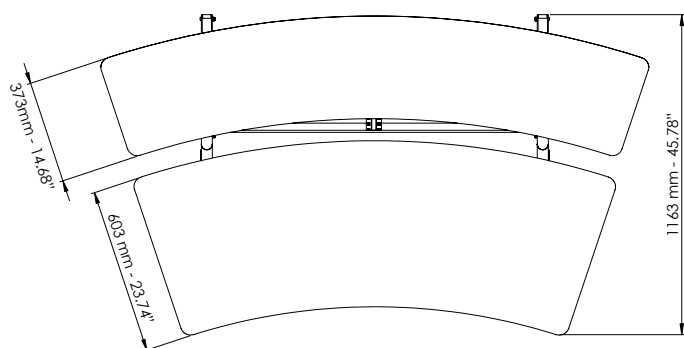

Workstations & Computer Furniture

Z/460 DESIGNER SERIES PROJECT WORKSTATION

- Ergonomically designed for maximum comfort and efficiency
- Sleek, attractive styling adds modern, elegant look to any work environment
- Feature scratch-resistant 3/4" (18 mm) thick laminate shelves, in black finish
- Computer-welded heavy duty steel frame provides tremendous weight capacity
- Powder-coating black enamel finish
- Accommodates all kinds of computer equipment and accessories

Z/460 BK

- Triple Shelf Workstation with black wood tops and pull-out shelf
- Includes a 4-space rack holder (easily removable if not required)

Main shelf dimensions:

Height from floor:	28.8" - 73.2 cm
Width:	44" - 111.8 cm
Depth:	22" - 55.9 cm
Thickness:	3/4" - 18 mm

Top shelf dimensions:

Height from floor:	38.8" - 98.6 cm
Width:	49.25" - 125 cm
Depth:	12.75" - 32.4 cm
Thickness:	3/4" - 18 mm

Pull-out shelf dimensions:

Height from floor:	25.8" - 65.7 cm
Width:	29.8" - 75.7 cm
Depth:	14" - 35.5 cm
Thickness:	3/4" - 18 mm

Overall dimensions:

Width:	49.37" - 125.4 cm
Depth:	33.46" - 85 cm
Height:	38.8" - 98.6 cm

Options: LPH/T, IPS/16



View of Z/460BK cable management rear channel

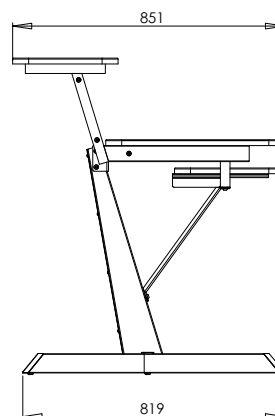
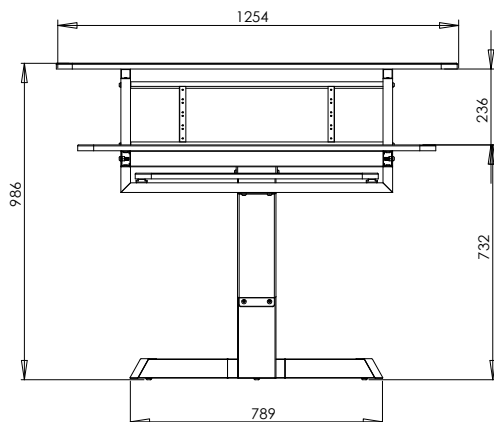

Z/612BK

- 12-Space companion rack stand, with contoured black wood top

Height: 28.9" - 73.5 cm
 Width: 24" - 61 cm
 Depth: 20.8 - 53 cm
 Weight capacity: 200 lb - 90.5 kg

Z/612BK AM

Supplied with 10/32" Whitworth (US thread) bolts & cagenuts

Z/612BK EU

Supplied with 6 mm Metric (European thread) bolts & cagenuts

Top Shelf dimensions:

Width: 30" - 76 cm
 Depth: 23.8" - 60.5 cm
 Thickness: 18 mm



View showing two possible configurations of Z/460BK project desk system in combination with Z/612BK rack stand

Z/612CY

- 12-Space companion rack stand, with contoured cherry wood top

Height: 28.9" - 73.5 cm
 Width: 24" - 61 cm
 Depth: 20.8 - 53 cm
 Weight capacity: 200 lb - 90.5 kg

Z/612CY AM

Supplied with 10/32" Whitworth (US thread) bolts & cagenuts

Z/612CY EU

Supplied with 6 mm Metric (European thread) bolts & cagenuts

Top Shelf dimensions:

Width: 30" - 76 cm
 Depth: 23.8" - 60.5 cm
 Thickness: 18 mm



Workstations & Computer Furniture



LPH/T

- Add-on laptop holder for studios and multi-media workstations.
- Can be securely anchored to any table top surface by means of its tightening clamp (adjustable up to 45 mm).
- Can accommodate virtually any size laptop 10.2" to 16.5" (26 to 42 cm) wide and 10.2" to 16.5" (26 to 42 cm) deep. Four stoppers, adjustable in width and depth, will securely anchor any size laptop, without interfering with input/output ports, expansion slots, cd-rw/dvd drivers, A/C adapter sockets placed on either side of the laptop.
- The laptop tray is height and tilt adjustable, and swivels at 360° to allow for ideal positioning.
- Equipped with pull-out mouse tray, that can be positioned on either the left or right side of the laptop, and is retractable for easy storage and transport.

Height adjustment*:	from 10.2" to 14.5" from 26 to 37 cm
Laptop tray dimensions:	10" x 10" 25 x 25 cm
Mouse tray dimensions:	5.3" x 5.3" 13.5 x 13.5 cm
Laptop stoppers width range:	from 10.2" to 16.5" from 26 to 42 cm
Laptop stoppers depth range:	from 10.2" to 16.5" from 26 to 42 cm
Clamp opening:	1.77" - 4.5 cm
Color:	Black

*measured from table top to bottom of laptop tray)



IPS/16

- Add-on universal tablet holder for studios and multi-media workstations.
- Can be securely anchored to any table top surface up to 72 mm thick (2.83") by means of its tightening clamp, but can also be connected to any stand with round tubing diameter of up to 50 mm (1.968").
- Clever, safe and practical design allows musicians to integrate their tablet with existing furniture, for use on stage, production studios, in the rehearsal room or at home.
- Will accommodate virtually any size tablet having side measurements ranging from 111 mm to 301 mm (4.37" to 11.85") and depth ranging from 6.9 mm to 18.7 mm (0.27" to 0.73").
- Flexible yet rugged rubberized plastic stoppers will hold the tablet firmly and securely in place, without interfering with dock connector, speaker, headphone jack, on/off and volume buttons.
- No-wobble, lightweight aluminium plate is designed to ensure full tilt and rotational adjustability, and to switch rapidly from the vertical to the horizontal viewing mode without slipping, for ideal positioning of your tablet.

Weight capacity:	33 lb - 15 kg
Color:	Titanium or Black



Details of IPS/16 tightening clamp device



Display Stands

SLATWALL DISPLAY ACCESSORIES

Quik-Lok's most popular choice to convert in-door store walls into a complete merchandising system. Quik-Lok slatwall accessories are the ideal solution to hold heavier musical merchandise like solid-body electric guitars, keyboards, sound modules, mixers, speakers, multi-track recorders, amps, guitars, computer peripherals, cymbals, cable reels and smaller music accessories such as instrument cables, straps, sheet music and others.



SLATWALL DISPLAY ACCESSORIES

- Quik-Lok's line of tiers, shelves and guitar holders designed for slatwall display
- Easy, safe and space-saving way to properly merchandise guitars, keyboards, sound modules, small mixers and amps, speakers, and computer peripherals
- Solid, heavy duty steel construction
- Black powder-coated finish

SW/602

- Short slatwall hanger for cymbals

Depth: 9.8" - 25 cm
Color: Black



SW/602L

- Long slatwall hanger for cymbals

Depth: 11.8" - 30 cm
Color: Black



SW/220L

- Slatwall double-wire display hook

Length: 7.9" - 20 cm
Color: Black



SW/222L

- Slatwall single-wire display hook

Length: 7.9" - 20 cm
Color: Black



Display Stands



SBK/20

- Multi-angle, depth-adjustable tier set for slatwall
- Designed to allow for 3 angle adjustments (1 straight, 2 slant angles).
- Steel safety pin to ensure maximum strength and safety.
- Two width-adjustable arms allow to accommodate any length product.
- Telescoping arms will hold any size keyboard, mixer, multi-track recorder, amp from 14.2" to 19.7" (36 to 50 cm) deep.

Depth range: from 14.2" to 19.7" from 36 to 50 cm
 Weight capacity: 50 lb - 22.6 kg
 Weight: 4 lb - 1.8 kg
 Color: Black



SBS/649

- Slatwall Large Perforated Shelf

Width: 18.5" - 47 cm
 Depth: 11.8" - 30 cm
 Weight capacity: 50 lb - 22.6 kg
 Weight: 4 lb - 1.8 kg
 Color: Black

SBS/649L

- Extra-large perforated metal shelf for slatwall display

Width: 45.27" - 115 cm
 Depth: 12.6" - 32 cm
 Weight capacity: 100 lb - 45 kg
 Weight: 14 lb - 6.3 kg
 Color: Black

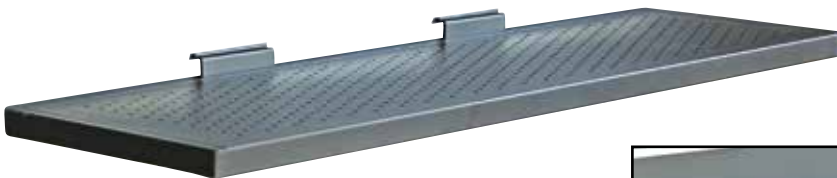

SLATWALL GUITAR HANGERS WITH PATENTED SELF-LOCKING YOKE

- Quik Lok introduces a new series of slatwall guitar hangers incorporating an ingenious device that allows for a secure and space-saving way to hold and display any size electric/acoustic guitar and bass.
- When the guitar is placed into the stand yoke, the instrument's weight will automatically drive the lateral safety barriers incorporated in the yoke to engage. The safety barriers turn down to lock the guitar neck securely in place, preventing the instrument from accidentally falling off the wall. When the guitar is lifted from the stand the security barriers will simultaneously turn back to their original position to free the instrument.
- Durable, smooth velveteen foam padding on yoke protects guitars from scratches and will not mar finish.
- Hanger swivels to accommodate all headstock shapes



SW/702

- Slatwall Guitar Hanger with self-locking yoke

Depth (wall to inside of holder):	4.13" - 10.5 cm
Total depth:	6.1" - 15.5 cm
Width:	4.33" - 11 cm
Yoke inner width:	0.20" - 53 mm
Weight capacity:	25 lb - 12.5 kg
Weight:	0.8 lb - 0.36 kg
Color:	Black



SW/702L

- Slatwall Guitar Hanger with self-locking yoke and long brace

Depth (wall to inside of holder):	9.45" - 24 cm
Total depth:	11.22" - 28.5 cm
Width:	4.33" - 11 cm
Yoke inner width:	0.20" - 53 mm
Weight capacity:	25 lb - 12.5 kg
Weight:	1.18 lb - 0.53 kg
Color:	Black



SW/702XL

- Slatwall Guitar Hanger with self-locking yoke and extra long brace

Depth (wall to inside of holder):	11.4" - 29 cm
Total depth:	13.2" - 33.5 cm
Width:	4.33" - 11 cm
Yoke inner width:	0.20" - 53 mm
Weight capacity:	25 lb - 12.5 kg
Weight:	1.2 lb - 0.54 kg
Color:	Black



CLASSIC SERIES SLATWALL GUITAR HANGERS



SBG/4

- Slatwall Guitar Hanger with Raised Front Forks

Depth (from wall to inside of holder):	3.6" - 9 cm
Total depth:	6.3" - 16 cm
Width:	3.5" - 9 cm
Weight capacity:	25 lb - 12.5 kg
Weight:	0.6 lb - 0.3 kg
Color:	Black



SBG/14

- Slatwall Guitar Hanger with Raised Front Forks and long brace
- 180° rotating forks can be adjusted either right angle or left-angle from wall

Depth (from wall to inside of holder):	7.5" - 19 cm
Total depth:	11" - 28 cm
Width:	3.5" - 9 cm
Weight capacity:	25 lb - 12.5 kg
Weight:	0.8 lb - 0.4 kg
Color:	Black



SBG/14L

- Slatwall Guitar Hanger with Raised Front Forks and extra long brace
- 180° rotating forks can be adjusted either right-angle or left-angle from wall

Depth (from wall to inside of holder):	9.6" - 24.5 cm
Total depth:	13" - 33 cm
Width:	23.2" - 59 cm
Cradle depth opening:	3.5" - 9 cm
Weight capacity:	25 lb - 12.5 kg
Weight:	1.1 lb - 0.5 kg
Color:	Black

CLASSIC SERIES WALL-MOUNTED GUITAR HANGERS

- Safe, space-saving way to hold and display guitars
- Solid all-steel construction
- Hanger swivels to accommodate all headstock shapes
- Soft, rubber cushioning protects guitar neck
- Supplied with all mounting hardware

GS/402

- Guitar Wall Hanger with Oval Contour
- Designed to insert guitar in sideways and turn

Depth (from wall to inside of holder):	3.6" - 9 cm
Total depth:	6.3" - 16 cm
Width:	3.5" - 9 cm
Diameter of mounting plate:	3.3" - 8.5 cm
Weight capacity*:	25 lb - 12.5 kg
Weight:	0.6 lb - 0.3 kg
Color:	Black

*[secured directly to wall stud]



GS/403

- Guitar Wall Hanger with Raised Front Forks
- Designed to lift guitar over front forks

Depth (from wall to inside of holder):	3.6" - 9 cm
Total depth:	6.3" - 16 cm
Width:	3.5" - 9 cm
Diameter of mounting plate:	3.3" - 8.5 cm
Weight capacity*:	25 lb - 12.5 kg
Weight:	0.6 lb - 0.3 kg
Color:	Black

*[secured directly to wall stud]



GS/454

- Guitar wall hanger with raised front forks and long brace 180° rotating forks can be adjusted either right-angle or left-angle from wall

Depth (from wall to inside of holder):	7.7" - 19.5 cm
Total depth:	11.2" - 28.5 cm
Width:	3.5" - 9 cm
Diameter of mounting plate:	3.3" - 8.5 cm
Weight capacity*:	25 lb - 12.5 kg
Weight:	1 lb - 0.45 kg
Color:	Black

*[secured directly to wall stud]



GS/454L

- Guitar wall hanger with raised front forks and extra long brace 180° rotating forks can be adjusted either right-angle or left-angle from wall

Depth (from wall to inside of holder):	9.6" - 24.5 cm
Total depth:	13" - 33 cm
Width:	3.5" - 9 cm
Diameter of mounting plate:	3.3" - 8.5 cm
Weight capacity*:	25 lb - 12.5 kg
Weight:	1.2 lb - 0.55 kg
Color:	Black

*[secured directly to wall stud]



GS/410

- Horizontal Acoustic Guitar Wall Hanger

Depth (from wall to inside of holder):	3" - 7.5 cm
Total depth:	8.5" - 21.5 cm
Width:	23.2" - 59 cm
Cradle depth opening:	5.1" - 13 cm
Weight capacity:	25 lb - 12.5 kg
Weight:	3.3 lb - 1.5 kg
Color:	Black



GS/413

- Horizontal Electric Guitar Wall Hanger

Depth (from wall to inside of holder):	3" - 7.5 cm
Total depth:	6.3" - 16 cm
Width:	23.2" - 59 cm
Cradle depth opening:	2" - 5 cm
Weight capacity:	25 lb - 12.5 kg
Weight:	3.3 lb - 1.5 kg
Color:	Black



GUITAR WALL-MOUNTS WITH NEW PATENTED SELF-LOCKING YOKE DESIGN

- Quik Lok introduces a new series of guitar wall-mounts incorporating an ingenious device that allows for a secure and space-saving way to hold and display any size electric/acoustic guitar and bass.
- When the guitar is placed into the stand yoke, the instrument's weight will automatically drive the lateral safety barriers incorporated in the yoke to engage. The safety barriers turn down to lock the guitar neck securely in place, preventing the instrument from accidentally falling off the wall. When the guitar is lifted from the stand the security barriers will simultaneously turn back to their original position to free the instrument.
- Durable, smooth velveteen foam padding on yoke protects guitars from scratches and will not mar finish.
- Hanger swivels to accommodate all headstock shapes



GS/701

- Guitar Wall-Mount with self-locking yoke
- Supplied with all mounting hardware

Depth (wall to inside of holder):	4.33" - 11 cm
Total depth:	6.1" - 15.5 cm
Width:	4.33" - 11 cm
Diameter of mounting plate:	3.3" - 8.5 cm
Yoke inner width:	0.20" - 53 mm
Weight capacity:	25 lb - 12.5 kg
Weight:	0.8 lb - 0.36 kg
Color:	Black



GS/701L

- Guitar Wall-Mount with self-locking yoke and long brace
- Supplied with all mounting hardware

Depth (wall to inside of holder):	10.23" - 26 cm
Total depth:	12" - 30.5 cm
Width:	4.33" - 11 cm
Diameter of mounting plate:	3.94" - 10 cm
Yoke inner width:	0.20" - 53 mm
Weight capacity:	25 lb - 12.5 kg
Weight:	1.18 lb - 0.53 kg
Color:	Black



GS/701XL

- Guitar Wall-Mount with self-locking yoke and extra long brace
- Supplied with all mounting hardware

Depth (wall to inside of holder):	12.2" - 31 cm
Total depth:	13.97" - 35.5 cm
Width:	4.33" - 11 cm
Diameter of mounting plate:	3.94" - 10 cm
Yoke inner width:	0.20" - 53 mm
Weight capacity:	25 lb - 12.5 kg
Weight:	1.2 lb - 0.54 kg
Color:	Black



Display Stands

THE “QF” SERIES DISPLAY SYSTEM OFFERS PROFITABLE AND EFFICIENT USE OF STORE SPACE

- Product display system designed to optimize store space and maximize profits
- Display all kinds of merchandise including keyboards, sound modules, mixers, speakers, multi-track recorders, amps, guitars, computer peripherals and more
- Customize each stand by adding any of the available height adjustable options which include a variety of shelves, tiers and guitar hangers
- Arc-Welded steel construction
- Easy to set up and assemble
- Available in black finish



QF/548

- 40" (100 cm) Wall-mounted display



Height:	40" - 100 cm
Depth from wall:	4.3" - 11 cm
Frame tube size:	30 x 15 mm
Weight capacity*:	refer to weight capacity of options
Weight:	5.5 lb - 2.5 kg
Color:	Black

* Not to exceed total weight of 100 lb - 45.2 kg when mounted directly to wall stud

Options: QF/410, QF/413, QF/597, QL/636

View showing a store-display application of the QF/548 fitted with QL/636 adjustable tiers



QL/636

- Large Tilt Adjustable Tier

Side to side width:	17.7" - 45 cm
Front to back usable depth:	13.8" - 35 cm
Usable angle positions:	90°, 81°, 72°, 63°, 54°
Weight capacity:	60 lb - 27.2 kg
Weight:	3.1 lb - 1.4 kg
Color:	Black



QF/597

- Large Perforated Metal Shelf

Width:	18.5" - 47 cm
Depth:	11.8" - 30 cm
Weight capacity:	50 lb - 22.6 kg
Weight:	4 lb - 1.8 kg
Color:	Black

QF/51

- Free-standing, 2-sided Column Display Stand
- Stand-alone display column with sturdy 4-legged base
- Heavy duty steel construction
- Four-leg base for absolute stability
- Holds up to 8 guitars firmly in place, as well as related accessories by means of the proper support shelves
- Ideal for store displays, trade shows or studios
- Can be folded down without tools for easy transport
- The QF/51 includes a very useful metal clamp to hold an advertising sign up to 5 mm thick (as pictured on right)

Base spread diameter:	3' - 90 cm
Center tubing size:	30x15 mm (x2)
Set-up height:	6.7' - 202 cm
Weight capacity:	265 lb - 120 kg
Weight:	13.1 lb - 5.9 kg
Color:	Black

Options: QF/410, QF/413, QF/597, QL/636

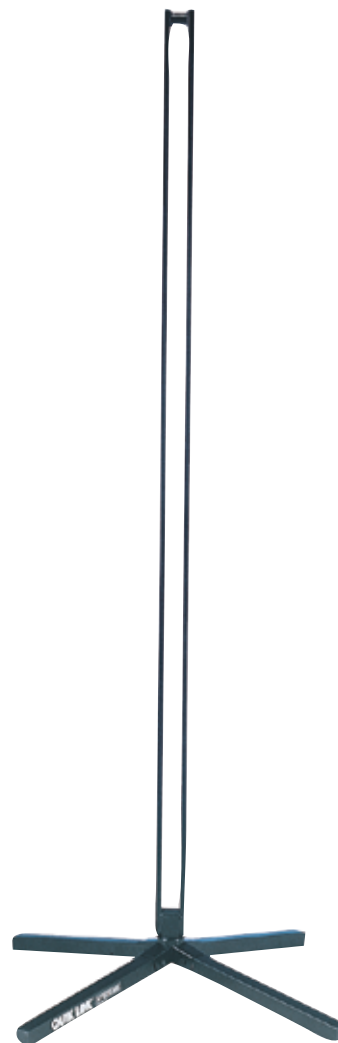

QF/410

- Horizontal Acoustic Guitar Hanger
Designed to be used with QF/51 and QF/548 only

Depth*:	3" - 7.5 cm
Total depth:	8.5" - 21.5 cm
Width:	23.2" - 59 cm
Cradle depth opening:	5.1" - 13 cm
Weight capacity:	25 lb - 12.5 kg
Weight:	3.3 lb - 1.5 kg
Color:	Black

*(measured from column to inside of guitar holder)



QF/413

- Horizontal Electric Guitar Hanger
Designed to be used with QF/51 and QF/548 only

Depth*:	3" - 7.5 cm
Total depth:	6.3" - 16 cm
Width:	23.2" - 59 cm
Cradle depth opening:	2" - 5 cm
Weight capacity:	25 lb - 12.5 kg
Weight:	3.3 lb - 1.5 kg
Color:	Black

*(measured from column to inside of guitar holder)



Display Stands

REVOLVING DISPLAY STAND FOR 8 GUITARS

- Free-standing revolving display system designed to optimize store space and maximize profits.
- Holds up to 8 electric/acoustic guitars firmly in place.
- Arc-welded steel construction column with sturdy four-leg base for absolute stability.
- Ideal for store displays, trade shows or studios.
- Fast to set up and assemble, can be folded down without tools for easy transport.
- Available in black finish.

GS/405

- Revolving display stand for 8 electric/acoustic guitars

Set-up height:	78.74" - 200 cm
Base spread diameter:	33" - 84 cm
Center tubing size:	35 x 35 mm
Weight capacity:	133 lb - 60 kg
Weight:	20 lb - 9 kg
Color:	Black



CARTS



Carts

Band Wagon

EXPANDABLE EQUIPMENT HAULER WITH FOLDABLE HANDLES

- Ideal workmate for musicians and DJs, audio/video technicians and rental companies, the BW/768 Band Wagon cart is the perfect solution for transporting speaker cabinets and all musical instruments and equipment cases.
- Folds up small enough to be fit inside any car and easily concealed on stage (18.1"D x 34.2"W x 9.8"H - 46D x 87W x 25H cm).
- The telescoping frame bed telescopes from 29.5" to 50.4" (75 to 128 cm), letting you custom tailor your cart to the amount and size of gear you have.
- Innovative spring loaded locking system for placing the steering handle in the upright or folded position. Simply push the lever, move the handle to the desired position and release to lock.
- Exclusive design allows to set the Band Wagon to multiple configurations for use in the dolly or open cab, platform wagon and hand truck modes.
- Non-skid surfaces on the frame bed keep load from sliding around, and stair climbers are a back-saver, also allowing for attachment of bungee cords.
- Available with scratch-resistant, baked-on, black enamel finish on frame bed and titanium finish on handles.
- Non-skid surfaces on the frame bed keep load from sliding around, and airframe style stair climbers are a back-saver, also allowing for attachment of bungee cords.

BW/768

- Expandable equipment hauler with foldable handles

Frame bed telescoping length range:

From	29.5" to 50.4"
From	75 to 128 cm
Depth:	13.6" - 34.5 cm
Height from floor:	9" - 23 cm
Rear wheels:	7.87"x1.65" - 200x42mm
Front swivel casters:	3.93"x1.18" - 100x30mm
Handles height:	29.5" - 75 cm
Folded dimensions:	18.1"D x 34.2"W x 9.8"H 46D x 87W x 25H cm
Weight capacity:	600 lb - 270 kg
Weight:	33.3 lb - 15 kg
Color:	Black frame bed and titanium handles

8" polyurethane no-flat rear wheels with high-strength polymer hub are shock absorbing, easily navigate over rough or bumpy surfaces, as well as gravel and grass terrain.



Superior locking caster design locks the turning and pivoting positions simultaneously, securing your gear even on an incline.





CONTROL PEDALS



PS/20

- On/Off foot switch pedal
- Latched action On/Off pedal, ideal for amplifiers, guitars, effects, multitrack recorders, etc.
- Sturdy, compact nylon-moulded shell with 6-foot (1.8 mt) cable and 1/4" (6.3 mm) phone plug



PS/25

- Sustain pedal for electronic keyboards, drum machines and tone modules
- Momentary contact pedal with normally open or closed contacts by means of mode selector switch, ideal for all Korg, Casio, Yamaha, Akai, Roland, Studiologic, Ensoniq, Kawai and other electronic keyboards
- Sturdy, compact nylon-moulded shell with 6-foot (1.8 mt) cable and 1/4" (6.3 mm) phone plug



COMMA TYPE SUSTAIN PEDALS

PSP/125

- Classic piano style sustain pedal
- Momentary contact pedal with normally open or closed contacts by means of mode selector switch, ideal for all Korg, Casio, Yamaha, Akai, Roland, Studiologic, Ensoniq, Kawai and other electronic keyboards
- Sturdy yet elegant, rubber-coated pedal with 6-foot (1.8 mt) cable and 1/4" (6.3 mm) phone plug



VOLUME PEDALS

VP/26 U

- The first UNIVERSAL VOLUME PEDAL designed to control the volumes of at least five different brands of keyboards on the market today; Roland, Yamaha, Korg, Kurzweil and Ensoniq, by simply changing the position of a polarity switch incorporated in the pedal.
- Technical data
- Mounts:
 - A custom potentiometer
 - A polarity switch
 - 3' (90 cm) stereo cable with a 1/4" (6.3 mm) stereo jack
 - Heavy shielded metal base plate



VOLUME PEDALS



VP/26-11

- Volume pedal
- The VP/26-11 is suitable for the control of a keyboard instrument or guitar.
- Built with two 6.3 mm (1/4") jack sockets for connection to the instrument and amplifier.
- Heavy metal base for a stable and safe use.
- Features high-performance custom potentiometer for a long-lasting life.



VP/26-22

- Volume pedal
- The VP/26-22 is suitable for the control of two instruments at the same time a keyboard instrument or guitar.
- Built with two 6.3 mm (1/4") jack input sockets for connection to the instruments and a further two 6.3 mm (1/4") jack output sockets for connection to the amplifier.
- Heavy metal base for a stable and safe use.
- Features high-performance custom potentiometer for a long-lasting life.
- External potentiometer allows for manual sensitivity adjustments.

ASSEMBLED
CABLES



Assembled Cables

STRIX

SERIES INSTRUMENT, MICROPHONE & AUDIO ADAPTOR CABLES



SX/764

Instrument Cable

Mono 6.3 mm metal jack plug
Basic series cable
Mono 6.3 mm metal jack plug

Lengths (meters): 1 - 2 - 3 - 4.5 - 6 - 9
Wire colours: Black (BK)



MX/775

Microphone Cable

XLR Female connector
Basic series cable
XLR Male connector

Lengths (meters): 3 - 5 - 9
Wire colours: Black (BK)



MX/777

Microphone Cable

XLR Female connector
Basic series cable
Mono 6.3 mm metal jack plug

Lengths (meters): 3 - 5 - 9
Wire colours: Black (BK)



MX/779

Microphone Cable

XLR Male connector
Basic series cable
Mono 6.3 mm metal jack plug

Lengths (meters): 3 - 5 - 9
Wire colours: Black (BK)

SX/4K

Adaptor cable

Stereo 6.3 mm jack plug (moulded)
Basic series cable
Two mono 6.3 mm jack plugs (moulded)

Lengths (meters): 2.5 - 5
 Wire colours: Black (BK)



SX/12K

Adaptor cable

Stereo 6.3 mm jack plug (moulded)
Basic series cable
Two RCA phono plugs (moulded)

Lengths (meters): 3 - 5
 Wire colours: Black (BK)



SX/275K

Adaptor cable

Two mono 6.3 mm jack plugs (moulded)
Basic series cable
Two mono 6.3 mm jack plugs (moulded)

Lengths (meters): 2 - 5
 Wire colours: Black (BK)



Assembled Cables



SX/276K

Adaptor cable

Stereo 3.5 mm jack plug (moulded)
Basic series cable
Stereo 3.5 mm jack plug (moulded)

Lengths (meters): 2 - 3
Wire colours: Black (BK)



SX/30K

Adaptor cable

Stereo 3.5 mm jack plug (moulded)
Basic series cable
Two mono 6.3 mm jack plugs (moulded)

Lengths (meters): 3
Wire colours: Black (BK)



SX/40K

Adaptor cable

Stereo 3.5 mm jack plug (moulded)
Basic series cable
Two RCA phono plugs (moulded)

Lengths (meters): 3
Wire colours: Black (BK)



SX/164

Midi Cable

5-Pole Male DIN connector (moulded plastic plug)
Basic series midi cable
5-Pole Male DIN connector (moulded plastic plug)

Lengths (meters): 0.5 - 1 - 1.5 - 2 - 3 - 5 - 9
Wire colours: Black (BK)

ROK SOLID

SERIES INSTRUMENT, MICROPHONE & AUDIO ADAPTOR CABLES

- The **RokSolid** Professional Cable Series redefines the essence of high-performance cable interfaces, with sleek contemporary design and superior technology, tested by the most prominent Italian laboratories.
- Manufactured to endure the most challenging situations, the **RokSolid** product line is engineered using professional **"Superflex"** cable featuring ultra-pure oxygen-free copper conductors for transparent signal transfer, thick spiral-style noise-rejecting shielding that protects the signal from outside interferences, resistant durable PVC outer jacket for increased strength and flexibility.
- The **RokSolid** Series offers a wide variety of instrument, microphone and audio adaptor cables of excellent quality, distinguished by beautifully designed moulded connectors which allow for a supreme connection of your equipment to ensure outstanding performances time after time.

RKSI/200

Instrument Cable

Mono 6.3 mm QUIKLOK moulded jack plug
SUPERFLEX cable
Mono 6.3 mm QUIKLOK moulded jack plug

Lengths (meters): 1 - 2 - 3 - 4.5 - 6 - 9
Wire colours: Black (BK)



RKSI/205

Instrument Cable

Mono 6.3 mm QUIKLOK moulded right-angle jack plug
SUPERFLEX cable
Mono 6.3 mm QUIKLOK moulded jack plug

Lengths (meters): 1 - 3 - 4.5 - 6 - 9
Wire colours: Black (BK)

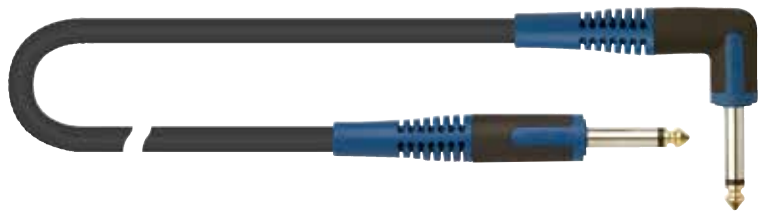

RKSI/207

Instrument Cable

Mono 6.3 mm QUIKLOK moulded right-angle jack plug
SUPERFLEX cable
Mono 6.3 mm QUIKLOK moulded right-angle jack plug

Lengths (meters): 0.2 - 1 - 3
Wire colours: Black (BK)



RKSI/202

Instrument Cable

Stereo 6.3 mm QUIKLOK moulded jack plug
SUPERFLEX cable
Stereo 6.3 mm QUIKLOK moulded jack plug

Lengths (meters): 1 - 2 - 3 - 5
Wire colours: Black (BK)



Assembled Cables



RKSM/340

Microphone Cable

XLR Female QUIKLOK moulded connector
SUPERFLEX cable
XLR Male QUIKLOK moulded connector

Lengths (meters): 1 - 2 - 3 - 5 - 9
Wire colours: Black (BK)



RKSM/342

Microphone Cable

XLR Female QUIKLOK moulded connector
SUPERFLEX cable
Stereo 6.3 mm QUIKLOK moulded jack plug

Lengths (meters): 3 - 5 - 9
Wire colours: Black (BK)



RKSM/344

Microphone Cable

XLR Male QUIKLOK moulded connector
SUPERFLEX cable
Stereo 6.3 mm QUIKLOK moulded jack plug

Lengths (meters): 2 - 3 - 5 - 9
Wire colours: Black (BK)

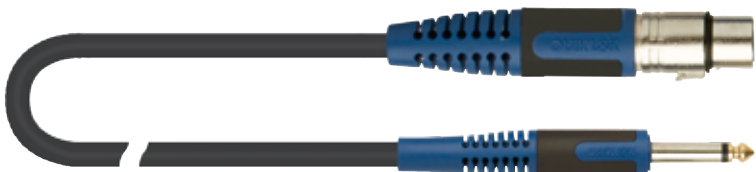

RKSM/300

Microphone Cable

XLR Female QUIKLOK moulded connector
SUPERFLEX cable
Mono 6.3 mm QUIKLOK moulded jack plug

Lengths (meters): 1 - 2 - 3 - 5 - 9
Wire colours: Black (BK)



RKSM/310

Microphone Cable

XLR Male QUIKLOK moulded connector
SUPERFLEX cable
Mono 6.3 mm QUIKLOK moulded jack plug

Lengths (meters): 3 - 5 - 9
Wire colours: Black (BK)



RKSA/100

Audio Adaptor Cable

Stereo 6.3 mm QUIKLOK moulded jack plug
SUPERFLEX cable
Two mono 6.3 mm QUIKLOK moulded jack plugs

Lengths (meters): 1 - 2 - 5
Wire colours: Black (BK)

RKSA/120

Audio Adaptor Cable

Two RCA QUIKLOK moulded phono plugs
SUPERFLEX cable
Stereo 6.3 mm QUIKLOK moulded jack plug

Lengths (meters): 1 - 2 - 5
 Wire colours: Black (BK)



RKSA/128

Audio Adaptor Cable

RCA QUIKLOK moulded phono plug
SUPERFLEX cable
Mono 6.3 mm QUIKLOK moulded jack plug

Lengths (meters): 2 - 5
 Wire colours: Black (BK)



RKSA/160

Audio Adaptor Cable

Two RCA QUIKLOK moulded phono plugs
SUPERFLEX cable
Mono 6.3 mm QUIKLOK moulded jack plug

Lengths (meters): 2 - 5
 Wire colours: Black (BK)



RKSA/130

Audio Adaptor Cable

Two RCA QUIKLOK moulded phono plugs
SUPERFLEX cable
Two mono 6.3 mm QUIKLOK moulded jack plugs

Lengths (meters): 1 - 2 - 5
 Wire colours: Black (BK)

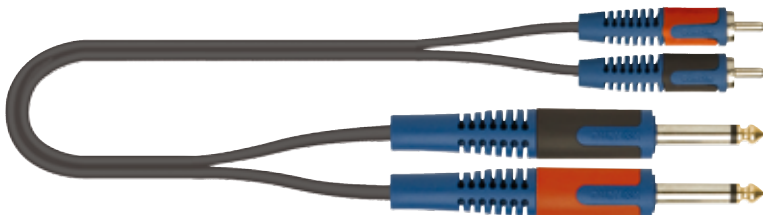

RKSA/110

Audio Adaptor Cable

Two RCA QUIKLOK moulded phono plugs
SUPERFLEX cable
Two RCA QUIKLOK moulded phono plugs

Lengths (meters): 1 - 1.5 - 2 - 3 - 5
 Wire colours: Black (BK)



RKSA/180

Audio Adaptor Cable

Two RCA QUIKLOK moulded phono plugs
SUPERFLEX cable
Two RCA QUIKLOK moulded phono sockets

Lengths (meters): 2 - 5
 Wire colours: Black (BK)



Assembled Cables



RKSA/132

Audio Adaptor Cable

RCA QUIKLOK moulded phono plug
SUPERFLEX cable
XLR Female QUIKLOK moulded connector

Lengths (meters): 2
Wire colours: Black (BK)



RKSA/133

Audio Adaptor Cable

RCA QUIKLOK moulded phono plug
SUPERFLEX cable
XLR Male QUIKLOK moulded connector

Lengths (meters): 2
Wire colours: Black (BK)



RKSA/138

Audio Adaptor Cable

Stereo 3.5 mm QUIKLOK moulded jack plug
SUPERFLEX cable
Stereo 3.5 mm QUIKLOK moulded jack plug

Lengths (meters): 1 - 2 - 3 - 5
Wire colours: Black (BK)



RKSA/139

Audio Adaptor Cable

Stereo 6.3 mm QUIKLOK moulded jack plug
SUPERFLEX cable
Stereo 3.5 mm QUIKLOK moulded jack plug

Lengths (meters): 1 - 2 - 3 - 5
Wire colours: Black (BK)

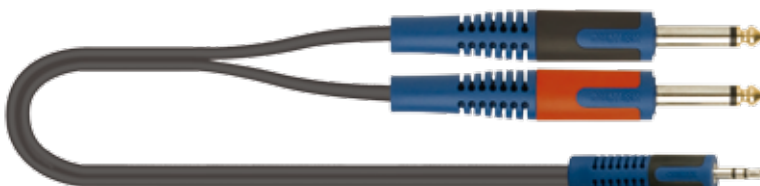

RKSA/140

Audio Adaptor Cable

Two mono 6.3 mm QUIKLOK moulded jack plugs
SUPERFLEX cable
Stereo 3.5 mm QUIKLOK moulded jack plug

Lengths (meters): 1 - 2 - 5
Wire colours: Black (BK)



RKSA/150

Audio Adaptor Cable

Two RCA QUIKLOK moulded phono plugs
SUPERFLEX cable
Stereo 3.5 mm QUIKLOK moulded jack plug

Lengths (meters): 1 - 2 - 5
Wire colours: Black (BK)

RKSA/192

Audio Adaptor Cable

Stereo 3.5 mm QUIKLOK moulded jack plug
SUPERFLEX cable
Two XLR Male QUIKLOK moulded connectors

Lengths (meters): 2 - 3 - 5
 Wire colours: Black (BK)



RKSA/194

Audio Adaptor Cable

Stereo 3.5 mm QUIKLOK moulded jack plug
SUPERFLEX cable
Two XLR Female QUIKLOK moulded connectors

Lengths (meters): 2 - 3 - 5
 Wire colours: Black (BK)

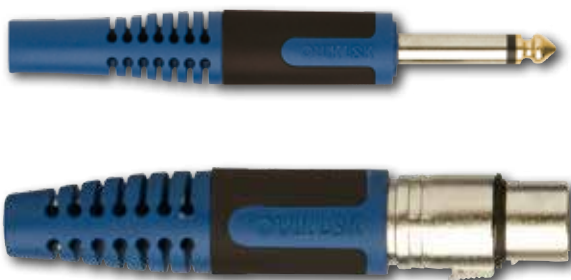



STANDARD BLACK SERIES INSTRUMENT, MICROPHONE & AUDIO ADAPTOR CABLES

S/200K

Instrument Cable

Mono 6.3 mm metal jack plug
CS535K cable
Mono 6.3 mm metal jack plug

Lengths (meters): 0.5 - 1 - 2 - 3 - 4.5 - 6 - 9
 Wire colours: Black (BK)



STR/601K

Instrument Cable

Mono 6.3 mm metal jack plug
CS535K cable
Mono 6.3 mm metal jack plug

Lengths (meters): 0.5 - 1 - 2 - 3 - 4.5 - 6 - 9
 Wire colours: Black (BK)

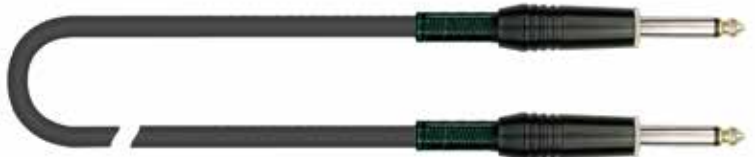

STR/603K

Instrument Cable

Mono 6.3 mm right-angle metal jack plug
CS535K cable
Mono 6.3 mm metal jack plug

Lengths (meters): 3 - 4.5 - 6
 Wire colours: Black (BK)



STR/604K

Instrument Cable

Mono 6.3 mm right-angle metal jack plug
CS535K cable
Mono 6.3 mm right-angle metal jack plug

Lengths (meters): 0.2 - 0.5 - 1 - 2
 Wire colours: Black (BK)



STR/602K

Instrument Cable

Stereo 6.3 mm metal jack plug
CM995K cable
Stereo 6.3 mm metal jack plug

Lengths (meters): 1 - 2 - 3 - 4.5
 Wire colours: Black (BK)



STR/616K

Adaptor cable

Two Mono 6.3 mm metal jack plugs
CM822K Multicore flat cable
Two Mono 6.3 mm metal jack plugs

Lengths (meters): 2 - 3 - 4.5 - 6
 Wire colours: Black (BK)



Assembled Cables



CM/175K

Microphone Cable

XLR Female connector
CM675K cable
XLR Male connector

Lengths (meters): 0.5 - 1 - 2 - 3 - 4.5 - 6 - 9 - 15 - 20
Wire colours: Black (BK)

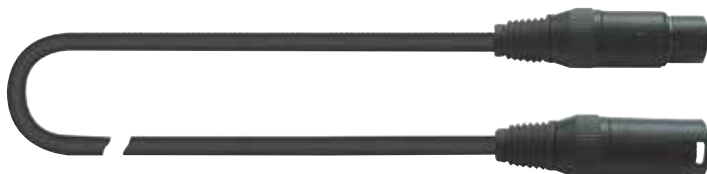

MCR/611K

Microphone Cable

XLR Female connector
CM995K cable
XLR Male connector

Lengths (meters): 0.5 - 1 - 2 - 3 - 4.5 - 6 - 9 - 15 - 20
Wire colours: Black (BK)



MCR/614K

Microphone Cable

XLR Female connector
CM995K cable
Stereo 6.3 mm metal jack plug

Lengths (meters): 1 - 2 - 3 - 4.5 - 6
Wire colours: Black (BK)



MCR/615K

Microphone Cable

XLR Male connector
CM995K cable
Stereo 6.3 mm metal jack plug

Lengths (meters): 1 - 2 - 3 - 4.5 - 6
Wire colours: Black (BK)



MCR/612K

Microphone Cable

XLR Female connector
CM995K cable
Mono 6.3 mm metal jack plug

Lengths (meters): 1 - 2 - 3 - 4.5 - 6 - 9
Wire colours: Black (BK)



MCR/613K

Microphone Cable

XLR Male connector
CM995K cable
Mono 6.3 mm metal jack plug

Lengths (meters): 1 - 2 - 3 - 4.5 - 6 - 9
Wire colours: Black (BK)

MCR/616K

Adaptor Cable

XLR Female connector
CM995K cable
RCA metal phono plug

Lengths (meters): 2 - 3
 Wire colours: Black (BK)



MCR/617K

Adaptor Cable

XLR Male connector
CM995K cable
RCA metal phono plug

Lengths (meters): 2 - 3
 Wire colours: Black (BK)



STR/605K

Adaptor Cable

Stereo 6.3 mm metal jack plug
CM840K cable
Two Mono 6.3 mm metal jack plugs

Lengths (meters): 2 - 3 - 5
 Wire colours: Black (BK)



STR/607K

Adaptor Cable

Two RCA metal phono plugs
CM840K cable
Stereo 6.3 mm metal jack plug

Lengths (meters): 2 - 3 - 5
 Wire colours: Black (BK)



STR/617K

Adaptor Cable

Stereo 6.3 mm metal jack plug
CM675K cable
Stereo 6.3 mm metal jack socket

Lengths (meters): 3
 Wire colours: Black (BK)



STR/618K

Adaptor Cable

Stereo 6.3 mm metal jack plug
CM840K cable
Two stereo 6.3 mm metal jack sockets

Lengths (meters): 0.3
 Wire colours: Black (BK)



Assembled Cables



STR/619K

Adaptor cable

Stereo 6.3 mm metal jack plug
CM805K cable
Stereo 3.5 mm metal jack socket

Lengths (meters): 3 - 5
Wire colours: Black (BK)



STR/610K

Adaptor Cable

Two RCA metal phono plugs
CM822K cable
Two Mono 6.3 mm metal jack plugs

Lengths (meters): 2 - 3
Wire colours: Black (BK)



STR/613K

Adaptor Cable

Two RCA metal phono plugs
CM82K2 cable
Two RCA metal phono plugs

Lengths (meters): 0.5 - 1 - 2 - 3 - 5
Wire colours: Black (BK)



STR/614K

Adaptor cable

Mono 6.3 mm metal jack plug
CS535K cable
Mono 3.5 mm metal jack plug

Lengths (meters): 3
Wire colours: Black (BK)



STR/608K

Adaptor Cable

Stereo 3.5 mm metal jack plug
CM805K cable
Stereo 3.5 mm metal jack plug

Lengths (meters): 1 - 2 - 3 - 5
Wire colours: Black (BK)



STR/615K

Adaptor cable

Stereo 3.5 mm metal jack plug
CM805K cable
Stereo 3.5 mm metal jack socket

Lengths (meters): 3 - 5
Wire colours: Black (BK)

STR/606K

Adaptor Cable

Stereo 3.5 mm metal jack plug
CM805K cable
Stereo 6.3 mm metal jack plug

Lengths (meters): 1 - 2 - 3 - 5
 Wire colours: Black (BK)



STR/611K

Adaptor Cable

Two Mono 6.3 mm metal jack plugs
CM840K cable
Stereo 3.5 mm metal jack plug

Lengths (meters): 1 - 2 - 3 - 5
 Wire colours: Black (BK)



STR/612K

Adaptor Cable

Two RCA metal phono plugs
CM840K cable
Stereo 3.5 mm metal jack plug

Lengths (meters): 1 - 2 - 3 - 5
 Wire colours: Black (BK)



STR/620K

Adaptor Cable

Mini XLR Female connector
CM805K cable
XLR Male connector

Lengths (meters): 2
 Wire colours: Black (BK)



JUST

HIGH PERFORMANCE CABLES

The QUIK LOK® cable dedicated to everyday application in the audio field, from stage to rehearsal studio.

Respectful of your signal: flexible, durable, featuring **gold-plated pins** and **metal skin-tops**.

Elegant and hard-wearing, thanks to the outer sheath with exclusive rope design for a special “**velvet**” effect.



JUST SERIES INSTRUMENT, MICROPHONE & AUDIO ADAPTOR CABLES

JUST JJ

Instrument Cable

Mono 6.3 mm metal jack plug
CSJUST cable
Mono 6.3 mm metal jack plug

Lengths (meters): 1 - 2 - 3 - 4.5 - 6 - 9
 Wire colours: Black (BK)



JUST JJ SL

Instrument Cable

Mono 6.3 mm metal jack plug
CSJUST cable
Mono 6.3 mm metal jack plug

Lengths (meters): 1 - 2 - 3 - 4.5 - 6 - 9
 Wire colours: Black (BK)



JUST JR

Instrument Cable

Mono 6.3 mm right-angle metal jack plug
CSJUST cable
Mono 6.3 mm metal jack plug

Lengths (meters): 1 - 2 - 3 - 4.5 - 6 - 9
 Wire colours: Black (BK)



JUST JR SL

Instrument Cable

Mono 6.3 mm right-angle metal jack plug
CSJUST cable
Mono 6.3 mm metal jack plug

Lengths (meters): 1 - 2 - 3 - 4.5 - 6 - 9
 Wire colours: Black (BK)



JUST 2JR

Instrument Cable

Mono 6.3 mm right-angle metal jack plug
CSJUST cable
Mono 6.3 mm right-angle metal jack plug

Lengths (meters): 0.2 - 0.3 - 0.5 - 1
 Wire colours: Black (BK)



JUST JS

Instrument Cable

Stereo 6.3 mm metal jack plug
CSJUST cable
Stereo 6.3 mm metal jack plug

Lengths (meters): 1 - 2 - 3 - 5
 Wire colours: Black (BK)



Assembled Cables



JUST MF

Microphone Cable

XLR Female connector
CMJUST cable
XLR Male connector

Lengths (meters): 0.5 - 1 - 2 - 3 - 5 - 10 - 15 - 20
Wire colours: Black (BK)



JUST MF SL

Microphone Cable

XLR Female connector
CMJUST cable
XLR Male connector

Lengths (meters): 0.5 - 1 - 2 - 3 - 5 - 10 - 15 - 20
Wire colours: Black (BK)



JUST FJS

Microphone Cable

XLR Female connector
CMJUST cable
Stereo 6.3 mm metal jack plug

Lengths (meters): 1 - 2 - 3 - 5 - 10
Wire colours: Black (BK)



JUST MJS

Microphone Cable

XLR Male connector
CMJUST cable
Stereo 6.3 mm metal jack plug

Lengths (meters): 1 - 2 - 3 - 5 - 10
Wire colours: Black (BK)



JUST FJM

Microphone Cable

XLR Female connector
CMJUST cable
Mono 6.3 mm metal jack plug

Lengths (meters): 1 - 2 - 3 - 5 - 10
Wire colours: Black (BK)



JUST MJM

Microphone Cable

XLR Male connector
CMJUST cable
Mono 6.3 mm metal jack plug

Lengths (meters): 1 - 2 - 3 - 5 - 10
Wire colours: Black (BK)

JUST KEY

Adaptor cable

Two Mono 6.3 mm metal jack plugs
CMJUST cable
Two Mono 6.3 mm metal jack plugs

Lengths (meters): 1 - 2 - 3 - 4.5 - 6
 Wire colours: Black (BK)

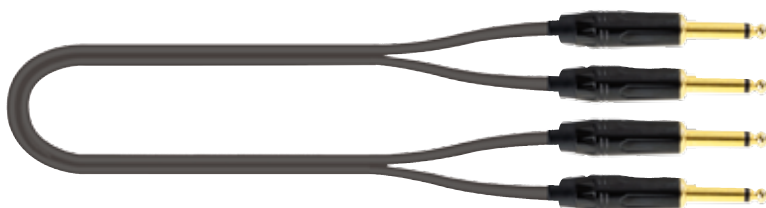

JUST JS2JM

Adaptor Cable

Stereo 6.3 mm metal jack plug
CMJUST cable
Two Mono 6.3 mm metal jack plugs

Lengths (meters): 1 - 2 - 3 - 5
 Wire colours: Black (BK)

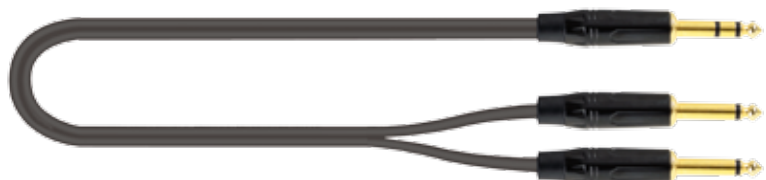

JUST JS2RCA

Adaptor Cable

Stereo 6.3 mm metal jack plug
CMJUST cable
Two RCA metal phono plugs

Lengths (meters): 1 - 2 - 3 - 5
 Wire colours: Black (BK)



JUST 4RCA

Adaptor Cable

Two RCA metal phono plugs
CMJUST cable
Two RCA metal phono plugs

Lengths (meters): 1 - 2 - 3 - 5
 Wire colours: Black (BK)



JUST 2RCA2J

Adaptor Cable

Two RCA metal phono plugs
CMJUST cable
Two Mono 6.3 mm metal jack plugs

Lengths (meters): 1 - 2 - 3 - 5
 Wire colours: Black (BK)



JUST JM35JM

Adaptor cable

Mono 3.5 mm metal jack plug
CMJUST cable
Mono 6.3 mm metal jack plug

Lengths (meters): 1 - 2 - 3
 Wire colours: Black (BK)



Assembled Cables



JUST J35JS

Adaptor Cable

Stereo 3.5 mm metal jack plug
CMJUST cable
Stereo 6.3 mm metal jack plug

Lengths (meters): 1 - 2 - 3 - 5
Wire colours: Black (BK)



JUST J35J35

Adaptor Cable

Stereo 3.5 mm metal jack plug
CMJUST cable
Stereo 3.5 mm metal jack plug

Lengths (meters): 1 - 2 - 3 - 5
Wire colours: Black (BK)



JUST J35J35F

Adaptor cable

Stereo 3.5 mm metal jack plug
CMJUST cable
Stereo 3.5 mm metal jack socket

Lengths (meters): 2 - 3 - 5
Wire colours: Black (BK)



JUST J352J

Adaptor Cable

Stereo 3.5 mm metal jack plug
CMJUST cable
Two Mono 6.3 mm metal jack plugs

Lengths (meters): 1 - 2 - 3 - 5
Wire colours: Black (BK)



JUST J352RCA

Adaptor Cable

Stereo 3.5 mm metal jack plug
CMJUST cable
Two RCA metal phono plugs

Lengths (meters): 1 - 2 - 3 - 5
Wire colours: Black (BK)

FPC QUIKBOARD FLAT PATCH CABLES

The new FPC QUIKBOARD patch cables are extremely high-quality cables designed by Quik Lok to maximize space on your pedalboard. Their slender, ultra-thin shape allows for a neat cable management of your pedalboard, helping to save space and preventing annoying tangles of cables. Featuring extra-slim, right-angle 6.3 mm mono jack plugs with gold-plated contacts. Available in black colour, in a wide variety of lengths ranging from 10 cm to 90 cm (4" to 3'), to accommodate any musician's needs.



FPC/QUIKBOARD

Patch Cable

FPC/QUIKBOARD 0.10

Lengths (meters): 0.10 - 4"
Wire colours: Black (BK)



FPC/QB-0.10



FPC/QB-0.15



FPC/QB-0.20

FPC/QUIKBOARD 0.15

Lengths (meters): 0.15 - 6"
Wire colours: Black (BK)

FPC/QUIKBOARD 0.20

Lengths (meters): 0.20 - 8"
Wire colours: Black (BK)

FPC/QUIKBOARD 0.30

Lengths (meters): 0.30 - 1'
Wire colours: Black (BK)



FPC/QB-0.30



FPC/QB-0.50



FPC/QB-0.60

FPC/QUIKBOARD 0.50

Lengths (meters): 0.50 - 20"
Wire colours: Black (BK)

FPC/QUIKBOARD 0.60

Lengths (meters): 0.60 - 2'
Wire colours: Black (BK)



FPC/QB-0.90

FPC/QUIKBOARD 0.90

Lengths (meters): 0.90 - 3'
Wire colours: Black (BK)

FPC/QUIKBOARD JAR PACK

Mix of 65 assorted length flat patch cables

Contents:

- 10pcs in 0.10m - 4" length
- 10pcs in 0.15m - 6" length
- 15pcs in 0.20m - 8" length
- 15pcs in 0.30m - 1' length
- 5pcs in 0.50m - 20" length
- 5pcs in 0.60m - 2' length
- 5pcs in 0.90m - 3' length



Assembled Cables



QUIK LOK CABLES: DESIGNED AND MANUFACTURED IN ITALY USING OUR HEAD AND FOLLOWING OUR HEART!!!

- The line of Italian-made Quik Lok cables is manufactured according to a simple but essential company principle, that all musicians can trust and rely on: High Quality, First and Foremost, at all price levels!!
- The bulk cable that we use in the making of our packaged leads is thoroughly produced in Italy by a European-leading manufacturer, to the strictest copper purity standards, and in full compliance with the most severe regulations set to guarantee high-quality cable conductors, insulation, shielding and flexibility.
- The technical specifications of all bulk cable models utilized in the making of our pre-assembled cable items are clearly described in the Bulk Cable section of our general product catalogue, available as reference to all Quik Lok users.
- We utilize very unique bulk cable models In the manufacturing of our line of pre-made Special Guitar Cables, exclusively designed for Quik Lok, specifically engineered by our R&D staff. By combining our vast experience in the music field and our passion for guitar with the excellent manufacturing skills and sophisticated technology of our cable production plant, we were able to create a line of very high-end guitar cables that serve the purpose of dramatically improving the sound of the most popular musical instrument of modern age and allow the most demanding professional guitar players to highly enhance their performance.
- Soldering on our whole Made in Italy cable line is performed following a state-of-the art production procedure, in full compliance with ROHS regulations, and all assembled cables are individually tested for quality to literally eliminate any chance of failure on the job.
- The connectors employed in each one of our numerous pre-assembled cable series are selected based on the price range that each series is targeting, scrupulously aiming at achieving the best Quality/Price ratio possible in the case of our STANDARD Series, whereas no room for compromise is left when it comes to our PROFESSIONAL Series and our SPECIAL GUITAR CABLE Series, where Total Quality becomes our one and only priority.
- Our STANDARD Series cables are assembled with great quality connectors that are Made in China under our supervision, most of which of Quik Lok's proprietary design. On the other hand, our PROFESSIONAL Series and our SPECIAL GUITAR CABLE Series exclusively employ the finest connectors available in the industry nowadays, such as original Neutrik connectors (strictly of Swiss manufacturing) and the ever so popular Amphenol connectors (Made in Australia).
- In our mind, cables are not just a plain, ordinary accessory, but a serious, crucial component of any musician's gear. A poor quality cable connecting your beloved instrument to your amplifier and signal processors is surely going to seriously jeopardize the end result of your performance, and will undoubtedly fail to deliver your sound the way you had envisioned it, the way it was meant to be, causing your expensive, high-tech equipment and extraordinary musical talent to become completely meaningless.

This is the reason why at Quik Lok we are committed to providing far more than a simple amp-to-guitar cable interface, nothing but a fully reliable, trustworthy connection means made to the highest quality standards, a cable incorporating outstanding features and amazing personality, a precious working tool that will help you enhance your performance tremendously and will truly become a vital part of your music.

When picking your cables don't compromise, go for the best, choose Quik Lok cables and feel the difference!

STANDARD SILVER SERIES INSTRUMENT & MICROPHONE CABLES MADE IN ITALY 

S/204

Instrument Cable

Mono 6.3 mm QUIKLOK metal jack plug

CS535 cable

Mono 6.3 mm QUIKLOK metal jack plug

Lengths (meters): 0.5 - 1 - 2 - 3 - 4.5 - 6 - 9

Wire colours: Black (BK)



S/205

Instrument Cable

Mono 6.3 mm QUIKLOK metal right-angle jack plug

CS535 cable

Mono 6.3 mm QUIKLOK metal jack plug

Lengths (meters): 3 - 4.5 - 6

Wire colours: Black (BK)



S/206

Instrument Cable

Stereo 6.3 mm QUIKLOK metal jack plug

CM675 cable

Stereo 6.3 mm QUIKLOK metal jack plug

Lengths (meters): 0.5 - 1 - 2 - 3 - 4.5 - 6

Wire colours: Black (BK)



Assembled Cables



CM/204

Microphone Cable

XLR Female QUIKLOK connector
CM995 cable
XLR Male QUIKLOK connector

Lengths (meters): 0.5 - 1 - 2 - 3 - 4.5 - 6 - 9 - 15 - 20
Wire colours: Black (BK)



CM/207

Microphone Cable

XLR Female QUIKLOK connector
CM995 cable
Stereo 6.3 mm QUIKLOK metal jack plug

Lengths (meters): 4.5 - 6 - 9 - 15
Wire colours: Black (BK)



CM/208

Microphone Cable

XLR Male QUIKLOK connector
CM995 cable
Stereo 6.3 mm QUIKLOK metal jack plug

Lengths (meters): 4.5 - 6 - 9 - 15
Wire colours: Black (BK)



CM/205

Microphone Cable

XLR Female QUIKLOK connector
CM995 cable
Mono 6.3 mm QUIKLOK metal jack plug

Lengths (meters): 1 - 2 - 3 - 4.5 - 6 - 9
Wire colours: Black (BK)



CM/206

Microphone Cable

XLR Male QUIKLOK connector
CM995 cable
Mono 6.3 mm QUIKLOK metal jack plug

Lengths (meters): 0.25 - 1 - 2 - 3 - 4.5 - 6 - 9
Wire colours: Black (BK)

**PROFESSIONAL SILVER SERIES INSTRUMENT, MICROPHONE & AUDIO
ADAPTOR CABLES** MADE IN ITALY



S/210

Instrument Cable

Mono 6.3 mm SLIM metal jack plug

CS732 cable

Mono 6.3 mm SLIM metal jack plug

Lengths (meters): 0.5 - 1 - 2 - 3 - 4.5 - 6 - 9

Wire colours: Black (BK)



S/211

Instrument Cable

Mono 6.3 mm SLIM metal right-angle jack plug

CS732 cable

Mono 6.3 mm SLIM metal jack plug

Lengths (meters): 3 - 4.5 - 6

Wire colours: Black (BK)



S/213

Instrument Cable

Mono 6.3 mm SLIM metal right-angle jack plug

CS732 cable

Mono 6.3 mm SLIM metal right-angle jack plug

Lengths (meters): 0.5 - 1 - 2 - 3

Wire colours: Black (BK)



Assembled Cables

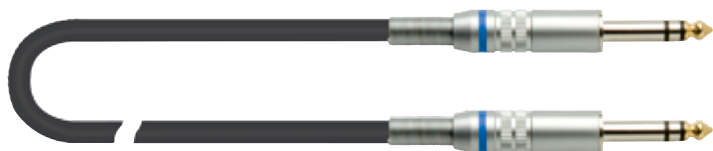

S/214

Instrument Cable

Stereo 6.3 mm SLIM metal jack plug
CM780 cable
Stereo 6.3 mm SLIM metal jack plug

Lengths (meters): 1 - 2 - 3 - 4.5 - 6 - 9
Wire colours: Black (BK)



CM/180

Microphone Cable

XLR Female connector
CM780 cable
XLR Male connector

Lengths (meters): 1 - 2 - 3 - 4.5 - 6 - 9 - 15 - 20
Wire colours: Black (BK)



CM/188

Microphone Cable

XLR Female connector
CM780 cable
Stereo 6.3 mm SLIM metal jack plug

Lengths (meters): 1 - 2 - 3 - 4.5 - 6 - 9
Wire colours: Black (BK)



CM/189

Microphone Cable

XLR Male connector
CM780 cable
Stereo 6.3 mm SLIM metal jack plug

Lengths (meters): 1 - 2 - 3 - 4.5 - 6 - 9
Wire colours: Black (BK)



CM/181

Microphone Cable

XLR Female connector
CM780 cable
Mono 6.3 mm SLIM metal jack plug

Lengths (meters): 4.5 - 6 - 9
Wire colours: Black (BK)



CM/182

Microphone Cable

XLR Male connector
CM780 cable
Mono 6.3 mm SLIM metal jack plug

Lengths (meters): 1 - 2 - 3 - 4.5 - 6 - 9
Wire colours: Black (BK)

CM/183F

Adaptor Cable

XLR Female connector
CM995 cable
RCA metal phono plug

Lengths (meters): 1 - 2 - 3 - 6
 Wire colours: Black (BK)



CM/183M

Adaptor Cable

XLR Male connector
CM995 cable
RCA metal phono plug

Lengths (meters): 1 - 2 - 3 - 6
 Wire colours: Black (BK)



S/215

Adaptor Cable

Two Mono 6.3 mm SLIM metal jack plugs
CM840 cable
Stereo 6.3 mm SLIM metal jack plug

Lengths (meters): 1 - 3 - 6
 Wire colours: Black (BK)



S/217

Adaptor Cable

Two RCA metal phono plugs
CM840 cable
Stereo 6.3 mm SLIM metal jack plug

Lengths (meters): 1 - 2 - 3 - 6
 Wire colours: Black (BK)



S/218

Adaptor Cable

Stereo 3,5 mm SLIM metal jack plug
CM805 cable
Stereo 3,5 mm SLIM metal jack plug

Lengths (meters): 1 - 2 - 3 - 6
 Wire colours: Black (BK)



S/216

Adaptor Cable

Stereo 6.3 mm SLIM metal jack plug
CM805 cable
Stereo 3,5 mm SLIM metal jack plug

Lengths (meters): 1 - 2 - 3 - 6
 Wire colours: Black (BK)



Assembled Cables



S/221

Adaptor Cable

Two Mono 6,3 mm SLIM metal jack plugs
CM840 cable
Stereo 3,5 mm SLIM metal jack plug

Lengths (meters): 1 - 2 - 3 - 6
Wire colours: Black (BK)



S/223

Adaptor Cable

Two RCA metal phono plugs
CM840 cable
Stereo 3,5 mm SLIM metal jack plug

Lengths (meters): 1 - 2 - 3 - 6
Wire colours: Black (BK)



S/220

Adaptor Cable

Two RCA metal phono plugs
CM822 cable
Two Mono 6,3 mm SLIM metal jack plugs

Lengths (meters): 1 - 2 - 3 - 6
Wire colours: Black (BK)



S/224

Adaptor Cable

Two RCA metal phono plugs
CM822 cable
Two RCA metal phono plugs

Lengths (meters): 1 - 2 - 3 - 6
Wire colours: Black (BK)

PROFESSIONAL BLACK SERIES INSTRUMENT, MICROPHONE & AUDIO ADAPTOR CABLES

MADE IN ITALY

SPB/310

Instrument Cable

Amphenol ACPM-GB Mono 6.3 mm metal jack plug
CS732 cable

Amphenol ACPM-GB Mono 6.3 mm metal jack plug

Lengths (meters): 0.5 - 1 - 2 - 3 - 5 - 9

Wire colours: Black (BK)



SPB/311

Instrument Cable

Amphenol ACPM-RB Mono 6.3 mm metal 90° jack plug
CS732 cable

Amphenol ACPM-GB Mono 6.3 mm metal jack plug

Lengths (meters): 1 - 2 - 3 - 5

Wire colours: Black (BK)



SPB/312

Instrument Cable

Amphenol ACPM-RB Mono 6.3 mm metal 90° jack plug
CS732 cable

Amphenol ACPM-RB Mono 6.3 mm metal 90° jack plug

Lengths (meters): 0.5 - 1

Wire colours: Black (BK)



Assembled Cables



SPB/313

Instrument Cable

**Amphenol ACPS-GB Stereo 6.3 mm metal jack plug
CM780 cable
Amphenol ACPS-GB Stereo 6.3 mm metal jack plug**

Lengths (meters): 0.5 - 1 - 2 - 3 - 5
Wire colours: Black (BK)



MPB/412

Microphone Cable

**Amphenol AC3FB XLR Female connector
CM780 cable
Amphenol AC3MB XLR Male connector**

Lengths (meters): 1 - 2 - 3 - 5 - 9 - 15
Wire colours: Black (BK)



MPB/418

Microphone Cable

**Amphenol AC3FB XLR Female connector
CM780 cable
Amphenol ACPS-GB Stereo 6.3 mm metal jack plug**

Lengths (meters): 1 - 2 - 3 - 5 - 9 - 15
Wire colours: Black (BK)



MPB/419

Microphone Cable

**Amphenol AC3MB XLR Male connector
CM780 cable
Amphenol ACPS-GB Stereo 6.3 mm metal jack plug**

Lengths (meters): 1 - 2 - 3 - 5 - 9 - 15
Wire colours: Black (BK)



SPB/317

Adaptor Cable

**Amphenol KM3PB Stereo 3.5 mm metal jack plug
CM805 cable
Amphenol KM3PB Stereo 3.5 mm metal jack plug**

Lengths (meters): 0.5 - 1 - 2 - 3
Wire colours: Black (BK)

SPB/316

Adaptor Cable

Amphenol KM3PB Stereo 3.5 mm metal jack plug
CM840 cable
Two Amphenol ACPM-GB Mono 6.3 mm metal jack plugs

Lengths (meters): 1 - 2 - 3
 Wire colours: Black (BK)



SPB/322

Adaptor Cable

Amphenol KM3PB Stereo 3.5 mm metal jack plug
CM840 cable
Two Amphenol ACPR-BLK/RED RCA metal phono plugs

Lengths (meters): 1 - 2 - 3
 Wire colours: Black (BK)



SPB/320

Adaptor Cable

Two Amphenol ACPM-GB Mono 6.3 mm metal jack plugs
CM822 cable
Two Amphenol ACPR-BLK/RED RCA metal phono plugs

Lengths (meters): 1 - 2 - 3 - 5
 Wire colours: Black (BK)



SPB/323

Adaptor Cable

Two Amphenol ACPR-BLK/RED RCA metal phono plugs
CM822 cable
Two Amphenol ACPR-BLK/RED RCA metal phono plugs

Lengths (meters): 1 - 2 - 3 - 5
 Wire colours: Black (BK)

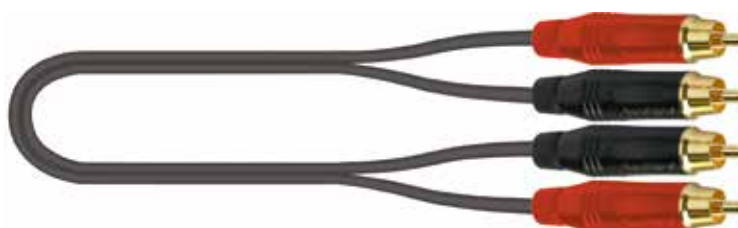



S/198AM

Instrument Cable

Amphenol TM2PB Mono 6.3 mm metal jack plug
CS732 cable
Amphenol TM2PB Mono 6.3 mm metal jack plug

Lengths (meters): 3 - 4.5 - 6 - 9
Wire colours: Black (BK)



S/160AM

Instrument Cable

Amphenol TM2RB Mono 6.3 mm metal 90° jack plug
CS732 cable
Amphenol TM2PB Mono 6.3 mm metal jack plug

Lengths (meters): 4.5 - 6
Wire colours: Black (BK)



CM/175AM

Microphone Cable

Amphenol AX3F XLR Female connector
CM780 cable
Amphenol AX3M XLR Male connector

Lengths (meters): 3 - 4.5 - 6 - 9 - 15
Wire colours: Black (BK)



**PROFESSIONAL PN SERIES INSTRUMENT, MICROPHONE & AUDIO
ADAPTOR CABLES** MADE IN ITALY

S/198PN

Instrument Cable

Neutrik NP2X mono 6.3 mm metal jack plug
CS732 cable
Neutrik NP2X mono 6.3 mm metal jack plug

Lengths (meters): 3 - 4.5 - 6 - 9
Wire colours: Black (BK)



S/160PN

Instrument Cable

Neutrik NP2RX mono 6.3 mm metal right-angle jack plug
CS732 cable
Neutrik NP2X mono 6.3 mm metal jack plug

Lengths (meters): 4.5 - 6
Wire colours: Black (BK)



S/167PN

Instrument Cable

Neutrik NP3X stereo 6.3 mm metal jack plug
CM780 cable
Neutrik NP3X stereo 6.3 mm metal jack plug

Lengths (meters): 2 - 4.5
Wire colours: Black (BK)





CM/175PN

Microphone Cable

Neutrik NC3FXX XLR Female connector
CM780 cable
Neutrik NC3MXX XLR Male connector

Lengths (meters): 1 - 2 - 3 - 4.5 - 6 - 9 - 15 - 20
Wire colours: Black (BK)



CM/184PN

Microphone Cable

Neutrik NC3FXX XLR Female connector
CM780 cable
Neutrik NP2X mono 6.3 mm metal jack plug

Lengths (meters): 4.5 - 6 - 9 - 15
Wire colours: Black (BK)



CM/186PN

Microphone Cable

Neutrik NC3MXX XLR Male connector
CM780 cable
Neutrik NP2X mono 6.3 mm metal jack plug

Lengths (meters): 4.5 - 6 - 9
Wire colours: Black (BK)



AD/100PN

Adaptor cable

Mini XLR Female connector
CM805 cable
Neutrik NC3MXX XLR Male connector

Lengths (meters): 2
Wire colours: Black (BK)



AD/87PN

Adaptor cable

Stereo 3.5 mm metal jack plug
CM805 cable
Neutrik NTP3RC stereo 3.5 mm right-angle metal jack plug

Lengths (meters): 3 - 5
Wire colours: Black (BK)



SONIC SOLUTIONS for Musicians



SONIC SOLUTIONS SERIES HIGH DEFINITION INSTRUMENT CABLES MADE IN ITALY

Through a long research process carried out at our laboratories in Italy, our technicians and a team of professional musicians with extensive experience in the music industry have finalized something that goes well beyond a simple cable product, a true working mode providing SOLUTIONS for musicians, the **SONIC SOLUTIONS** cable.

This is the cable required by musicians to address their specific need to carry the instrument's sound to the amplifier in the most **transparent** and natural way possible.

The **SS[ONE]** SONIC SOLUTIONS cable presents very different timbre characteristics, not because it acts as a sound equalizer but because it features a different way of carrying the signal from the instruments – most especially the higher harmonics that particularly determine and distinguish timbre.

Conceived, designed, manufactured and distributed by the **SONIC SOLUTIONS by Quik Lok** working group, this cable is 100% made in Italy! This innovative technology allows to drastically lower the capacitance to 56 Pf/mt and achieve absolute sound fidelity.

Whether utilized with electric, acoustic or bass guitars, keyboards or others, this special cable accurately delivers the exact sound produced by the instrument all the way through to the output connection.

Astonishingly broad frequency response, extremely low distortion and full signal transparency are the unique, distinctive features that truly identify the **SS[ONE]** as the **HIGH DEFINITION MUSICAL INSTRUMENT CABLE** par excellence.

Try out our SS[ONE] cable, compare it with other high-end cables and you will be amazed by the sound difference!

Note: When using SONIC SOLUTIONS Cables for multiple connections it is highly recommended to keep consistent with the same cable type on the whole signal chain. This allows to maintain intact the specific audio characteristics that the cable provides and preserve the unique sound quality that it is expected to deliver.



SS/ONE

Instrument Cable

Amphenol TM2PB Mono 6.3 mm metal jack plug
Sonic Solutions One cable
Amphenol TM2PB Mono 6.3 mm metal jack plug

Lengths (meters): 3 - 5
Wire colours: Black (BK)



SS/ONE-SIL

Instrument Cable

Amphenol TM1PB Mono 6.3 mm metal jack plug with signal switch
Sonic Solutions One cable
Amphenol TM2PB Mono 6.3 mm metal jack plug

Lengths (meters): 3 - 5
Wire colours: Black (BK)



SS/ONE-A

Instrument Cable

Amphenol TM2RB Mono 6.3 mm metal right-angle jack plug
Sonic Solutions One cable
Amphenol TM2PB Mono 6.3 mm metal jack plug

Lengths (meters): 3 - 5
Wire colours: Black (BK)



SS/ONE-AA

Pedal Connecting Cable

Amphenol ACPM-RB Mono 6.3 mm right-angle jack plug
Sonic Solutions One cable
Amphenol ACPM-RB Mono 6.3 mm right-angle jack plug

Lengths (meters): 0.1 - 0.15 - 0.2 - 0.3 - 0.5
Wire colours: Black (BK)

SS/TRUE CONNECTION HIGH DEFINITION INSTRUMENT CABLE

The Sonic Solutions **TRUE CONNECTION** cable is 100% Made in Italy, created by the intuition of guitar virtuoso Massimo Varini and sound guru Marco Brunetti.

The perfect cable for those who generate their own sound with an audio interface, whether at home, in a studio or live. The **TRUE CONNECTION** permits to dynamically adapt the pickups' impedance to the input given by digital sound generators.

Digital systems have become a significant part of a guitarist setup, due to the benefits in terms of practicality and costs, but something seems to have gone lost.

The amplifiers input and the guitars output have electrical characteristics that should be considered when they are connected.

The cable capacity, the impedance and the pickups resonance could distort the instrument's timbre if they are not balanced one to another.

Those who use amp-emulators, profilers, digital pre-amps, multi effects or pedal-buffers will find in **TRUE CONNECTION** a real and natural sound through the direct connection between electric guitar and amp.

The most evident results are shown with the single coil or the splitted humbucker. The sound becomes warmer and less acid: from the most rock-sounding and distorted to the cleanest and brilliant sounds!

TRUE CONNECTION uses the SS/ONE cable. It symbiotically works with a circulation that has been studied in the domain of the fundamental guitar's frequencies. Guitarists and bassists will have a complete frequency range, totally balanced and respectful of the instruments characteristics. **TRUE CONNECTION** is the dynamic answer for those who use digital systems and a real connection between man, guitar and amplifier!!!



SS/TRUE CONNECTION

Instrument Cable

Amphenol TM2PB Mono 6.3 mm metal jack plug
Sonic Solutions One cable
Amphenol TM2PB Mono 6.3 mm metal jack plug

Lengths (meters): 5
 Wire colours: Black (BK)

SONIC SOLUTIONS SERIES HIGH DEFINITION MICROPHONE CABLES

Through a long research process carried out at our laboratories in Italy, our technicians and a team of professional musicians have finalized the **SONIC SOLUTIONS** by QUIK LOK Microphone Cable.

This is the cable required by musicians to address their specific need to carry the exact sound produced by their instruments in the most **transparent** and natural way possible.

The innovative concept applied to this cable is the result of a new technology thoroughly developed at our R&D department in Italy.

This technology ensures a surprisingly strong and well defined signal, an excellent sound/noise ratio and absolute sound fidelity:

whether supporting the performance of a vocalist or utilized with electric, acoustic or bass guitars, keyboards or others, this special cable accurately delivers the sound exactly as produced, all the way through to the output connection.

Ingenious, innovative shielding design makes of this cable the perfect solution to endure the stress of live performing, while full signal **transparency** makes it also ideal for use in recording studios where total sound fidelity is a must.

Astonishingly broad frequency response, extremely linear and well balanced, achieved especially thanks to a phenomenal 0,58 µH/mt inductance rate.

Such exclusive, distinctive characteristics truly identify the **SS[TWO]** as the **HIGH DEFINITION MICROPHONE CABLE** par excellence.

SS/TWO

Microphone Cable

Amphenol AX3F XLR Female connector
Sonic Solutions Two cable
Amphenol AX3M XLR Male connector

Lengths (meters): 2 - 3 - 5 - 7.5 - 9 - 15
 Wire colours: Black (BK)



Assembled Cables

SPECIAL GUITAR CABLES, UNIQUELY DESIGNED AND SPECIFICALLY ENGINEERED TO HIGHLY ENHANCE THE PERFORMANCE OF THE MOST DEMANDING PROFESSIONAL GUITAR PLAYERS

The passion for this instrument has led us to research and develop a series of highly specialized cables with the purpose of providing far more than a simple amp-to-guitar cable interface. These cables show a specific timber personality and amazing tone quality, as a result of the very particular technical specifications that distinguish the conductors utilized in the manufacturing of these models.

VITAMINA C Series: Designed using cable with a third outer conductor. The end result is an extremely well defined response, with light emphasis on both the output level and medium and extreme frequency range, particularly found in heavy sounds. Only very few other cables with standard or high output level can compare with such great features at such an affordable price. Excellent with clean sounds and a great match with high-gain channels.

QUIKSILVER Series: Built using cable with a third outer conductor, and silver-plated strands for the signal conductor. The outcome is a surprisingly linear response on the whole band, particularly as it relates to high frequencies, because of its unrivaled ability to enhance harmonics in a very pleasant way. Ideal for use with any electric strung instrument, and particularly with electro acoustic guitars and high-end digital keyboards.

UNICORE Series: Engineered using cable with an inner (0.50mm diameter) mono-conductor and a 100% tinned copper shielding. The use of a solid mono-conductor with increased dimension as opposed to a multi-strand conductor results in the best possible signal transmission. Enhanced dynamics, instantaneous signal onset and high output level, with remarkably linear frequency response. These are the excellent characteristics of this cable, which allow for a supreme quality connection between electric strung instruments, keyboards, outboard gear, amps, mixers, and most especially, effect pedals.



SPECIAL GUITAR CABLES **MADE IN ITALY**

VITAMINA C Series: Designed using cable with a third outer conductor. The end result is an extremely well defined response, with light emphasis on both the output level and medium and extreme frequency range, particularly found in heavy sounds. Only very few other cables with standard or high output level can compare with such great features at such an affordable price. Excellent with clean sounds and a great match with high-gain channels.



VITAMINA-C

Instrument Cable

Neutrik NP2XB custom mono 6.3 mm metal jack plug
Vitamina-C cable (6.8 mm diameter)
Neutrik NP2XB custom mono 6.3 mm metal jack plug

Lengths (meters): 3 - 4.5 - 6
 Wire colours: Orange



VITAMINA-C A5

Instrument Cable

Neutrik NP2RXB custom mono 6.3 mm angled metal jack plug
Vitamina-C cable (6.8 mm diameter)
Neutrik NP2XB custom mono 6.3 mm metal jack plug

Lengths (meters): 5
 Wire colours: Orange



FPC/V-C2

Pedal Connecting Cable

Amphenol ACPMRB mono 6.3 mm right-angle jack plug
Vitamina-C cable (6.8 mm diameter)
Amphenol ACPMRB mono 6.3 mm right-angle jack plug

Lengths (meters): 0.2
 Wire colours: Orange



VITAMINA-C BLACK

Instrument Cable

Neutrik NP2XB custom mono 6.3 mm metal jack plug
Vitamina-C cable (6.8 mm diameter)
Neutrik NP2XB custom mono 6.3 mm metal jack plug

Lengths (meters): 3 - 4.5 - 6
 Wire colours: Black (BK)



When using Vitamina-C, QuikSilver or Unicore Special Guitar Cables for multiple connections it is highly recommended to keep consistent with the same cable type on the whole signal chain. This allows to maintain intact the specific audio characteristics that the cable provides and preserve the unique sound quality that it is expected to deliver.

Assembled Cables



VITAMINA-C BLACK A5

Instrument Cable

Neutrik NP2RXB custom mono 6.3 mm angled metal jack plug
Vitamina-C cable (6.8 mm diameter)
Neutrik NP2XB custom mono 6.3 mm metal jack plug

Lengths (meters): 5
Wire colours: Black (BK)



VITAMINA-C BLACK S5

Instrument Cable

Neutrik NP2XB custom mono 6.3 mm metal jack plug
Vitamina-C cable (6.8 mm diameter)
Neutrik NP2X-AU-SILENT mono 6.3 mm metal jack plug

Lengths (meters): 5
Wire colours: Black (BK)



VITAMINA-C BLACK A5S

Instrument Cable

Neutrik NP2RX-AU-SILENT mono 6.3 mm angled metal jack plug
Vitamina-C cable (6.8 mm diameter)
Neutrik NP2XB custom mono 6.3 mm metal jack plug

Lengths (meters): 5
Wire colours: Black (BK)



SPECIAL GUITAR CABLES MADE IN ITALY

QUIKSILVER Series: Built using cable with a third outer conductor, and silver-plated strands for the signal conductor. The outcome is a surprisingly linear response on the whole band, particularly as it relates to high frequencies, because of its unrivaled ability to enhance harmonics in a very pleasant way. Ideal for use with any electric strung instrument, and particularly with electro acoustic guitars and high-end digital keyboards.

Quiksilver



QUIKSILVER

Instrument Cable

Neutrik NP2X mono 6.3 mm metal jack plug
QUIKSILVER PVC cable (6.8 mm diameter)
Neutrik NP2X mono 6.3 mm metal jack plug

Lengths (meters): 3 - 5
 Wire colours: Brick Red



QUIKSILVER A5

Instrument Cable

Neutrik NP2RX mono 6.3 mm metal right-angle jack plug
QUIKSILVER PVC cable (6.8 mm diameter)
Neutrik NP2X mono 6.3 mm metal jack plug

Lengths (meters): 5
 Wire colours: Brick Red



QUIKSILVER S5

Instrument Cable

Neutrik NP2X mono 6.3 mm metal jack plug
QUIKSILVER PVC cable (6.8 mm diameter)
Neutrik NP2X-AU-SILENT mono 6.3 mm metal jack plug

Lengths (meters): 5
 Wire colours: Brick Red



QUIKSILVER AS5

Instrument Cable

Neutrik NP2RX-AU-SILENT mono 6.3 mm angled metal jack plug
QUIKSILVER PVC cable (6.8 mm diameter)
Neutrik NP2X mono 6.3 mm metal jack plug

Lengths (meters): 5
 Wire colours: Brick Red



FPC/Q

Pedal Connecting Cable

Amphenol ACPMRB mono 6.3 mm right-angle jack plug
QUIKSILVER PVC cable (6.8 mm diameter)
Amphenol ACPMRB mono 6.3 mm right-angle jack plug

Lengths (meters): 0.2
 Wire colours: Brick Red

Assembled Cables

SPECIAL GUITAR CABLES

MADE IN ITALY

UNICORE Series: Engineered using cable with an inner (0.50mm diameter) mono-conductor and a 100% tinned copper shielding. The use of a solid mono-conductor with increased dimension as opposed to a multi-strand conductor results in the best possible signal transmission. Enhanced dynamics, instantaneous signal onset and high output level, with remarkably linear frequency response. These are the excellent characteristics of this cable, which allow for a supreme quality connection between electric strung instruments, keyboards, outboard gear, amps, mixers, and most especially, effect pedals.

unicore

UNICORE 5

Instrument Cable

Neutrik NP2X mono 6.3 mm metal jack plug

Unicore PVC cable (6.8 mm diameter)

Neutrik NP2X mono 6.3 mm metal jack plug

Lengths (meters): 5

Wire colours: Translucent Grey (TDG)



UNICORE 5A

Instrument Cable

Neutrik NP2RX mono 6.3 mm metal right-angle jack plug

Unicore PVC cable (6.8 mm diameter)

Neutrik NP2X mono 6.3 mm metal jack plug

Lengths (meters): 5

Wire colours: Translucent Grey (TDG)



FPC/UNI

Pedal Connecting Cable

Amphenol ACPMRB Mono 6.3 mm right-angle jack plug

Unicore PVC cable (6.8 mm diameter)

Amphenol ACPMRB Mono 6.3 mm right-angle jack plug

Lengths (meters): 0.2

Wire colours: Translucent gray (TDG)



CONNECTING CABLES FOR SPEAKER CABINET / AMP HEAD MADE IN ITALY



STACK

Amp-Head connecting cable

Mono 6.3 mm JUMBO metal jack plug
CA830 (2 x 2.5 mm) cable
Mono 6.3 mm JUMBO metal jack plug

Lengths (meters): 0.5 - 1 - 1.5
 Wire colours: Black (BK)

CONNECTING CABLES FOR NON POWERED SPEAKERS MADE IN ITALY



S/310

Speaker Cable

Mono 6.3 mm metal jack plug
CA810 (2 x 1 mm) cable
Mono 6.3 mm metal jack plug

Lengths (meters): 1 - 1.5 - 2 - 3 - 5 - 10 - 15 - 20
 Wire colours: Black (BK)



S/314

Speaker Cable

Mono 6.3 mm metal jack plug
CA810 (2 x 1 mm) cable
XLR Male connector

Lengths (meters): 3 - 5 - 10 - 15 - 20
 Wire colours: Black (BK)



S/318

Speaker Cable

XLR Female connector
CA810 (2 x 1 mm) cable
XLR Male connector

Lengths (meters): 5 - 10 - 15 - 20
 Wire colours: Black (BK)



S/320

Speaker Cable

Mono 6.3 mm metal jack plug
CA820 (2 x 1.5 mm) cable
Mono 6.3 mm metal jack plug

Lengths (meters): 5 - 10 - 15 - 20
 Wire colours: Black (BK)



S/431PD

Speaker Cable

Mono 6.3 mm JUMBO metal jack plug
CA830 (2 x 2.5 mm) cable
Mono 6.3 mm JUMBO metal jack plug

Lengths (meters): 5 - 10 - 15 - 20
 Wire colours: Black (BK)

Assembled Cables

S/380

Speaker Cable

4-pole Speakon connector
CA822 (2 x 2 mm) cable
4-pole Speakon connector

Lengths (meters): 2 - 5 - 10 - 15 - 20
Wire colours: Black (BK)



S/381

Speaker Cable

4-pole Speakon connector
CA820 (2 x 1.5 mm) cable
XLR Female connector

Lengths (meters): 0.2 - 2 - 5 - 10 - 15 - 20
Wire colours: Black (BK)



S/382

Speaker Cable

4-pole Speakon connector
CA820 (2 x 1.5 mm) cable
XLR Male connector

Lengths (meters): 0.2 - 2 - 5 - 10 - 15 - 20
Wire colours: Black (BK)



S/383

Speaker Cable

4-pole Speakon connector
CA820 (2 x 1.5 mm) cable
Mono 6.3 mm metal jack plug

Lengths (meters): 0.2 - 2 - 5 - 10 - 15 - 20
Wire colours: Black (BK)



S/345PN

Speaker Cable

Neutrik NL2FC 2-pole Speakon connector
CA822 (2 x 2 mm) cable
Neutrik NL2FC 2-pole Speakon connector

Lengths (meters): 5 - 10 - 15 - 20
Wire colours: Black (BK)

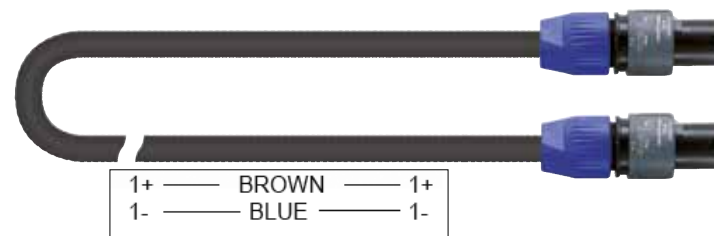

S/346PN

Speaker Cable

Neutrik NL4FX 4-pole Speakon connector
CA804 (4 x 2.5 mm) cable
Neutrik NL4FX 4-pole Speakon connector

Lengths (meters): 5 - 10 - 15 - 20
Wire colours: Black (BK)

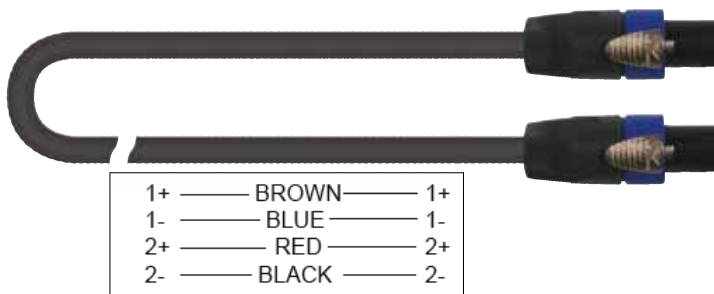

CONNECTING AUDIO/POWER CABLES FOR POWERED SPEAKERS 



S/396

Audio/Power Speaker Cable

XLR Male connector + Female IEC 60320-C13 standard socket

CA836 (3 x 1.5 mm power) mains/audio cable

XLR Female connector + Schuko type wall plug

Lengths (meters): 5 - 10 - 15 - 20

Wire colours: Black (BK)



S/398

Audio/Power Speaker Cable

XLR Male connector + Neutrik Powercon NAC3FCA (Power In) connector

CA836 (3 x 1.5 mm power) mains/audio cable

XLR Female connector + Neutrik Powercon NAC3FCB (Power Out) connector

Lengths (meters): 5 - 10 - 15 - 20

Wire colours: Black (BK)

MAINS CABLES



AAR 

AAR Series Array Mains Cable

Neutrik Powercon NAC3FCA (Power In) connector

CSF3015 (3 x 1.5 mm) cable

Neutrik Powercon NAC3FCB (Power Out) connector

Lengths (meters): 0.7

Wire colours: Black (BK)



S/1200 EU STND

Mains Cable

Schuko type wall plug

Female IEC 60320-C13 standard socket

Lengths (meters): 2

Wire colours: Black (BK)

Assembled Cables

MIDI CABLES

MADE IN ITALY

S/165

Midi Cable

5-Pole Male DIN metal connector
CM900 midi cable
5-Pole Male DIN metal connector

Lengths (meters): 1 - 2 - 3 - 4.5 - 6 - 9
Wire colours: Black (BK)



DIGITAL AUDIO CABLES

MADE IN ITALY

C-AES/EBU

Digital audio cable

Neutrik NC3FXXB XLR Female connector
CM818 AES/EBU cable (100 ohm)
Neutrik NC3MXXB XLR Male connector

Lengths (meters): 0.5 - 1 - 2 - 3
Wire colours: Black (BK)



DMX CONNECTION CABLES

MADE IN ITALY

DMX/1400

DMX connecting cable

5-Pin XLR Female connector (the control circuit uses only 3 of 5 pins)
CM818 Digital cable (3-Pole, 120 Ohm, suitable for up to 512 DMX channels)
5-Pin XLR Male connector (the control circuit uses only 3 of 5 pins)

Lengths (meters): 1 - 5 - 10 - 15 - 20
Wire colours: Black (BK)



DMX/1401

DMX connecting cable

3-Pin XLR Female connector
CM818 Digital cable (3-Pole, 120 Ohm, suitable for up to 512 DMX channels)
3-Pin XLR Male connector

Lengths (meters): 1 - 5 - 10 - 15 - 20
Wire colours: Black (BK)



DMX/1404

DMX connecting cable

5-Pin XLR Female connector
CMF832 Multicore cable (5-Pole, 120 Ohm, suitable for up to 512 DMX channels with 2 control signals)
5-Pin XLR Male connector

Lengths (meters): 1 - 5 - 10 - 15 - 20 - 25
Wire colours: Black (BK)



DIGITAL ETHERCON CABLES

MADE IN ITALY

ETH/5

Digital EtherCon Cat5e Cable
Designed to protect RJ45 connection contacts from breakage, meets the ever-growing requirements of data volume, transfer rate and bandwidth. The system is ideal for Ethernet applications in harsh, demanding environments such as audio, commercial, entertainment, live stage production, DMX lighting, outdoor Internet access and industrial Ethernet. Certificate 10Mbps / Certificate 100Mbps / Compatible 1Gbps | 100Mhz



Neutrik NE8MC-1 EtherCon RJ45 cable housing
ETH1004 Cat5E Ethernet cable
Neutrik NE8MC-1 EtherCon RJ45 cable housing

Lengths (meters): 5 - 10 - 20 - 30 - 40 - 50
Wire colours: Black (BK)

ETH5/61.5

Digital EtherCon Cat5e assembled cable metal drum
Specifically designed for use with Allen&Heat mixers and other similar digital mixing consoles



Neutrik NE8MC-1 EtherCon RJ45 cable housing
ETH1004 Cat5E Ethernet cable
Neutrik NE8MC-1 EtherCon RJ45 cable housing

Lengths: 61.5 mt. (203 ft.)
Wire colours: Black (BK)

ETH/6

Digital EtherCon Cat6 Cable
Designed for greater requirements of data volume, transfer rate and bandwidth. Ideal for Ethernet applications in audio, commercial, entertainment, live stage production, DMX lighting, outdoor Internet access and industrial Ethernet. Certificate 100Mbps / Certificate 1Gbps / Certificate 10Gbps (short distance) | 250Mhz



RJ45 EtherCon cable connector
ETH1007 Cat6 Ethernet cable
RJ45 EtherCon cable connector

Lengths (meters): 5 - 10 - 20 - 30 - 40 - 50
Wire colours: Black (BK)

ETH6/61.5

Digital EtherCon Cat6 assembled cable metal drum
Specifically designed for use with Allen&Heat mixers and other similar digital mixing consoles



Neutrik NE8MC-1 EtherCon RJ45 cable housing
ETH1007 Cat6 Ethernet cable
Neutrik NE8MC-1 EtherCon RJ45 cable housing

Lengths: 61.5 mt. (203 ft.)
Wire colours: Black (BK)

Assembled Cables

THE “600-K” SERIES OF STAGE BOX AUDIO SYSTEMS BY QUIK LOK

- Quik Lok introduces the “600-K” Series of stage box audio systems, designed to offer maximum value and guarantee absolute, consistent operation reliability.
- Heavy duty, powder coated, metal stagebox with integrated nylon handle.
- Built with flexible, professional multipair cable with black colour PVC jacket. Each pair contains 2x0.14mm² (24 AWG) conductors, each made of 7x0.16 twisted copper strands, with 100% foil shield and polyethylene insulation.
- Both panel and fanout feature high-grade quality, hand-soldered metal connectors with imprinted numbers and letters.
- Supplied with nylon carrying bag.



MODEL	PANEL	FAN-TAIL	CHANNELS	XLR TYPE	CABLE PAIRS	CABLE LENGTH
BOX/601-5K	8 x XLR Female	8 x XLR Male	8 Input Balanced	“K” series	8	5 mt. - 16.5 ft.
BOX/602-10K	8 x XLR Female	8 x XLR Male	8 Input Balanced	“K” series	8	10 mt. - 33 ft.
BOX/604-10K	8 x XLR Female 4 x XLR Male	8 x XLR Male 4 x XLR Female	8 Input Balanced 4 Output Balanced	“K” series	12	10 mt. - 33 ft.
BOX/605-20K	8 x XLR Female 4 x XLR Male	8 x XLR Male 4 x XLR Female	8 Input Balanced 4 Output Balanced	“K” series	12	20 mt. - 66 ft.
BOX/636-10K	16 x XLR Female 4 x XLR Male	16 x XLR Male 4 x XLR Female	16 Input Balanced 4 Output Balanced	“K” series	20	10 mt. - 33 ft.
BOX/637-20K	16 x XLR Female 4 x XLR Male	16 x XLR Male 4 x XLR Female	16 Input Balanced 4 Output Balanced	“K” series	20	20 mt. - 66 ft.
BOX/638-30K	16 x XLR Female 4 x XLR Male	16 x XLR Male 4 x XLR Female	16 Input Balanced 4 Output Balanced	“K” series	20	30 mt. - 99 ft.
BOX/640-20K	20 x XLR Female 4 x XLR Male	20 x XLR Male 4 x XLR Female	20 Input Balanced 4 Output Balanced	“K” series	24	20 mt. - 66 ft.
BOX/641-30K	20 x XLR Female 4 x XLR Male	20 x XLR Male 4 x XLR Female	20 Input Balanced 4 Output Balanced	“K” series	24	30 mt. - 99 ft.
BOX/643-20K	24 x XLR Female 8 x XLR Male	24 x XLR Male 8 x XLR Female	24 Input Balanced 8 Output Balanced	“K” series	32	20 mt. - 66 ft.
BOX/644-30K	24 x XLR Female 8 x XLR Male	24 x XLR Male 8 x XLR Female	24 Input Balanced 8 Output Balanced	“K” series	32	30 mt. - 99 ft.
BOX/646-20K	32 x XLR Female 8 x XLR Male	32 x XLR Male 8 x XLR Female	32 Input Balanced 8 Output Balanced	“K” series	40	20 mt. - 66 ft.
BOX/647-30K	32 x XLR Female 8 x XLR Male	32 x XLR Male 8 x XLR Female	32 Input Balanced 8 Output Balanced	“K” series	40	30 mt. - 99 ft.

BULK
CABLES



Bulk Cables

INSTRUMENT CABLES

SS/ONE SONIC SOLUTIONS HIGH DEFINITION INSTRUMENT CABLE

Through a long research process carried out at our laboratories in Italy, our technicians and a team of professional musicians with extensive experience in the music industry have finalized something that goes well beyond a simple cable product, a true working mode providing SOLUTIONS for musicians, the **SONIC SOLUTIONS** cable. This is the cable required by musicians to address their specific need to carry the instrument's sound to the amplifier in the most **transparent** and natural way possible.

The **SS[ONE]** SONIC SOLUTIONS cable presents very different timbre characteristics, not because it acts as a sound equalizer but because it features a different way of carrying the signal from the instruments – most especially the higher harmonics that particularly determine and distinguish timbre.

Conceived, designed, manufactured and distributed by the **SONIC SOLUTIONS by Quik Lok** working group, this cable is 100% made in Italy! This innovative technology allows to drastically lower the capacitance to 56 Pf/mt and achieve absolute sound fidelity.

Whether utilized with electric, acoustic or bass guitars, keyboards or others, this special cable accurately delivers the exact sound produced by the instrument all the way through to the output connection.

Astonishingly broad frequency response, extremely low distortion and full signal transparency are the unique, distinctive features that truly identify the **SS[ONE]** as the **HIGH DEFINITION MUSICAL INSTRUMENT CABLE** par excellence.



SS/ONE

High Definition Instrument Cable

Reel length (meters): **100**

Colours: Black (**BK**)



INSTRUMENT CABLES MADE IN ITALY

CS/535

Instrument Cable

Reel length (meters): **100**

Colours: Black **(BK)**



Specifications

Inner conductor size:	1 x 0.22 mm ² (22 AWG)
Strands x conductor:	7 x 0.20 Bare Copper (BC)
Insulation:	PE (Polyethylene) Ø 1.70 mm
Sub shielding:	100% Conductive PVC
Main shielding:	95% Copper Shield (5 x 8 served strands)
Outer jacket:	PVC Polyvinyl Chloride - Hardness grade: 65 Shore
Overall diameter:	6.00 mm
Weight:	38.5 Kg (85.56 lbs) per 1000 m (3280 ft)

Mechanical / Electric Characteristics

Conductor resistance at 20°:	<80 Ohm/Km
Capacitance:	110Pf/m
Insulation resistance at 20°:	>5000 Mohm/Km
Working temperature:	-30° ~ +70°

CS/732

Instrument Cable

Reel length (meters): **100**

Colours: Black **(BK)**



Specifications

Inner conductor size:	1 x 0.50 mm ² (20 AWG)
Strands x conductor:	28 x 0.15 Bare Copper (BC)
Insulation:	FHDPE (Foam High Density Polyethylene) Ø 2.20 mm
Sub shielding:	100% Conductive PVC
Main shielding:	95% Tinned Copper Shield (8 x 16 served strands)
Outer jacket:	Antistatic PVC Polyvinyl Chloride - Hardness grade: 60 Shore
Overall diameter:	6.35 mm
Weight:	47 Kg (104.44 lbs) per 1000 m (3280 ft)

Mechanical / Electric Characteristics

Conductor resistance at 20°:	<37 Ohm/Km
Capacitance:	135Pf/m
Insulation resistance at 20°:	>10000 Mohm/Km
Working temperature:	-30° ~ +70°



Bulk Cables

MICROPHONE CABLES

SS/TWO SONIC SOLUTIONS HIGH DEFINITION MICROPHONE CABLE

Through a long research process carried out at our laboratories in Italy, our technicians and a team of professional musicians have finalized the **SONIC SOLUTIONS** by QUIK LOK Microphone Cable. This is the cable required by musicians to address their specific need to carry the exact sound produced by their instruments in the most **transparent** and natural way possible.

The innovative concept applied to this cable is the result of a new technology thoroughly developed at our R&D department in Italy.

This technology ensures a surprisingly strong and well defined signal, an excellent sound/noise ratio and absolute sound fidelity: whether supporting the performance of a vocalist or utilized with electric, acoustic or bass guitars, keyboards or others, this special cable accurately delivers the sound exactly as produced, all the way through to the output connection.

Ingenious, innovative shielding design makes of this cable the perfect solution to endure the stress of live performing, while full signal **transparency** makes it also ideal for use in recording studios where total sound fidelity is a must.

Astonishingly broad frequency response, extremely linear and well balanced, achieved especially thanks to a phenomenal 0,58 $\mu\text{H}/\text{m}$ inductance rate.

Such exclusive, distinctive characteristics truly identify the **SS[TWO]** as the **HIGH DEFINITION MICROPHONE CABLE** par excellence.



Specifications

Inner conductor size:	2 x 0.35 mm ² (20 AWG)
Conductor strands:	0.10 mm Bare Copper
Insulation:	Dual color XLPE Polythene - Ø 1.70 mm
Core arrangement:	Twisted to pairs with cotton filling
Shielding:	Braided tinned copper shielding (cu 0,10 mm) + TNT tape
Outer jacket:	PVC Polyvinyl Chloride
Overall diameter:	6.00 mm
Weight:	51.5 Kg (114.44 lbs) per 1000 m (3280 ft)

Mechanical / Electric Characteristics

Conductor resistance at 20°:	$\leq 59 \text{ Ohm/Km}$
Shielding resistance at 20°:	$\leq 29 \text{ Ohm/Km}$
Impedance:	110 Ohm
Conductor/shielding capacitance:	185Pf/m
Conductor/conductor capacitance:	111Pf/m
Working temperature:	-30° - +70°

SS/TWO

High Definition Microphone Cable

Reel length (meters): **100**

Colours: Black (**BK**)

Note: When using SONIC SOLUTIONS Cable for multiple connections it is highly recommended to keep consistent with the same cable type on the whole signal chain. This allows to maintain intact the specific audio characteristics that the cable provides and preserve the unique sound quality that it is expected to deliver.



MICROPHONE CABLES

CM/580

Microphone Cable

Reel length (meters): **100**

Colours: Black **(BK)**



Specifications

Inner conductor size:	2 x 0.22 mm ² (Ø 1.40 mm)
Strands x conductor:	28 x 0.10 Stranded Bare Copper (BC)
Insulation:	Dual colour PE (Polyethylene)
Core arrangement:	Twisted to pairs with cotton filling
Shielding:	Bare copper coil shielding, 0.10 mm, 100% coverage + TNT foil
Outer jacket:	Flex PVC
Overall diameter:	6.40 mm
Weight:	51 Kg (113.33 lbs) per 1000 m (3280 ft)

Mechanical / Electric Characteristics

Conductor resistance at 20°C (Ohm/Km):	According to standard IEC 228/HD 383 S2 (CEI 20-29)
Resistance to flame propagation:	According to the standard IEC 332-1 (CEI 20-35)
Voltage Rating (V):	300/300
Voltage Test (V):	2.000
Working temperature:	+60°C

CM/675

Microphone Cable

Reel length (meters): **100 - 600**

Colours: Black **(BK)** - Blue **(BL)** - Red **(RE)**



Specifications

Inner conductor size:	2 x 0.22 mm ² (22 AWG)
Strands x conductor:	7 x 0.20 Bare Copper (BC)
Insulation:	PE (Polyethylene) Ø 1.45 mm
Shielding:	Bare copper 0.22 drain wire (7 x 0.20) + 100% Conductive PVC
Outer jacket:	PVC Polyvinyl Chloride - Hardness grade: 65 Shore
Overall diameter:	6.00 mm
Weight:	39.5 Kg (87.78 lbs) per 1000 m (3280 ft)

Mechanical / Electric Characteristics

Conductor resistance at 20°:	<52 Ohm/Km
Conductor/conductor capacitance:	60Pf/m
Insulation resistance at 20°:	>5000 Mohm/Km
Working temperature:	-30° ~ +70°

CM/995

Microphone Cable

Reel length (meters): **100**

Colours: Black **(BK)**



Specifications

Inner conductor size:	2 x 0.22 mm ² (24 AWG)
Strands x conductor:	28 x 0.10 Bare Copper (BC)
Insulation:	PVC Polyvinyl Chloride - Ø 1.45 mm
Core arrangement:	Twisted to pairs with cotton filling
Shielding:	Bare copper spiral shielding - 100% coverage
Outer jacket:	Super Flex PVC
Overall diameter:	6.30 mm
Weight:	50 Kg (111.11 lbs) per 1000 m (3280 ft)

Mechanical / Electric Characteristics

Conductor resistance at 20°:	<86 Ohm/Km
Conductor/shielding capacitance:	91Pf/m
Conductor/conductor capacitance:	58Pf/m
Insulation resistance at 20°:	>10000 Mohm/Km
Working temperature:	-20° ~ +70°

Bulk Cables

MICROPHONE CABLES



Specifications

Inner conductor size:	2 x 0.50 mm ² (20 AWG)
Strands x conductor:	28 x 0.15 Tinned Copper
Insulation:	Dual color LPE Polythene - Ø 1.70 mm
Core arrangement:	Twisted to pairs with drain wire and cotton filling
Shielding:	Braided tinned copper shielding (8 x 0.10) - 90% coverage
Outer jacket:	PVC Polyvinyl Chloride - Hardness grade: 60 Shore
Overall diameter:	6.35 mm
Weight:	51.5 Kg (114.44 lbs) per 1000 m (3280 ft)

Mechanical / Electric Characteristics

Conductor resistance at 20°:	<37 Ohm/Km
Conductor/shielding capacitance:	92Pf/m
Conductor/conductor capacitance:	54Pf/m
Insulation resistance at 20°:	>5000 Mohm/Km
Working temperature:	-30° ~ +70°

CM/780

Anti-static Microphone Cable

Reel length (meters): **100 - 600**

Colours: Black (**BK**)

MIDI CABLES



Specifications

Inner conductor size:	4 x 0.14 mm ² (26 AWG)
Strands x conductor:	18 x 0.10 Bare Copper (BC)
Insulation:	4-colour PVC Polyvinyl Chloride - Ø 1.10 mm
Shielding:	Braided 6 x 0.10 mm bare copper shielding - 90% coverage
Outer jacket:	PVC Polyvinyl Chloride - Hardness grade: 65 Shore
Overall diameter:	5.40 mm
Weight:	33 Kg (73.33 lbs) per 1000 m (3280 ft)

Mechanical / Electric Characteristics

Insulation resistance (20°):	<120 Ohm/km
Conductor resistance at 20°:	<127 Ohm/Km
Conductor/shielding capacitance:	126Pf/m
Conductor/conductor capacitance:	74Pf/m
Working temperature:	-30° ~ +70°

CM/900

Midi Cable

Reel length (meters): **100**

Colours: Black (**BK**)

CMF - SERIES MULTICORE AUDIO CABLES MADE IN ITALY

CMF/832 **CMF/834** **CMF/838**
CMF/842 **CMF/846** **CMF/854**
CMF/862 **CMF/865** **CMF/866**



	CMF/832	CMF/834	CMF/838
Specifications			
N° of Pairs:	2	4	8
Inner conductor size:	2 x 0.22 mm ² - Ø 1.20 mm		
Strands x conductor:	28 x 0.10 Tinned Bare Copper twisted to pairs		
Insulation:	LDPE - 0.25 mm thickness		
Shielding:	Served aluminium/polyester shield + 7 x 0.18 mm tinned copper drain wire - 100% coverage		
Single-pair jacket:	PVC Super Flex - Ø 3.0 mm - Black		
Outer jacket:	PVC Super Flex		
Overall diameter:	9.0 mm	10.4 mm	13.0 mm
Colours:	Black (BK)		
Copper weight per 1000 m (3280 ft):	12.7Kg (28.2lb)	26Kg (57.7lb)	51Kg (113.3lb)
Overall weight per 1000 m (3280 ft):	85Kg (189lb)	150Kg (333lb)	260Kg (578lb)

Mechanical / Electric Characteristics	
Inductance:	<0.60 MH/Km
Conductor resistance at 20°:	<128 Ohm/Km
Conductor/conductor capacitance:	52Pf/m
Conductor/shielding capacitance:	89Pf/m
Insulation resistance at 20°:	>10000 Mohm/Km
Working temperature:	-20° ~ +80°

CMF/842	CMF/846	CMF/854	CMF/862	CMF/865	CMF/866
12	16	24	32	48	56
2 x 0.14 mm ² [26 AWG]					
18 x 0.10 Flexible Bare Copper (BC) twisted to pairs					
Dual color Polyolefin - Ø 1.00 mm					
Served aluminium/polyester shield + 7 x 0.18 mm tinned copper drain wire - 100% coverage					
PVC Super Flex - Ø 2.70 mm					
PVC Super Flex					
15.2 mm	16.4 mm	20.4 mm	23.5 mm	28.8 mm	32.6 mm
Black (BK)					
243Kg (540lb)	290Kg (644lb)	426Kg (947lb)	586Kg (1302lb)	819Kg (1820lb)	945Kg (2100lb)

<0.60 MH/Km					
<128 Ohm/Km					
52Pf/m					
89Pf/m					
>10000 Mohm/Km					
-30° ~ +70°					

Bulk Cables

FLAT MULTICORE CABLES



	CM/840	CM/870
	2-Pair Flat Multicore Cable	4-Pair Flat Multicore Cable
Reel length (meters):	100	100
Colours:	Black (BK)	Black (BK)
Specifications		
Inner conductor size:	2 x 0.14 mm ² [25 AWG]	4 x 0.14 mm ² [25 AWG]
Strands x conductor:	18 x 0.10 Bare Copper (BC)	18 x 0.10 Bare Copper (BC)
Insulation:	PVC Polyvinyl Chloride Ø 1.15 mm	PVC Polyvinyl Chloride Ø 1.15 mm
Shielding:	Bare copper [5 x 0.10] spiral shielding - 95% coverage	Bare copper [5 x 0.10] spiral shielding - 95% coverage
Outer jacket:	PVC Polyvinyl Chloride - Hardness grade: 60 Shore	PVC Polyvinyl Chloride - Hardness grade: 60 Shore
Overall diameter:	3.20 mm x 2	2.40 mm x 4
Weight per 1000 m (3280 ft):	34 Kg (75.55 lbs)	38 Kg (84.44 lbs)
Mechanical / Electric Characteristics		
Conductor resistance at 20°:	<127 Ohm/Km	<127 Ohm/Km
Capacitance:	180Pf/m	180Pf/m
Working temperature:	-30° ~ +70°	-30° ~ +70°



Specifications	
Inner conductor size:	2 x 0.18 mm ² [25 AWG]
Strands x conductor:	10 x 0.15 Bare Copper (BC)
Insulation:	Dual color LPE Polythene - Ø 2.80 mm
Shielding:	Braided 4 x 0.10 bare copper shielding - 60% coverage
Outer jacket:	PVC Polyvinyl Chloride - Hardness grade: 60 Shore
Overall diameter:	5.40 mm x 2
Weight:	32 Kg (71.11 lbs) per 1000 m (3280 ft)
Mechanical / Electric Characteristics	
Conductor resistance at 20°:	<102 Ohm/Km
Conductor/shielding capacitance:	72Pf/m
Insulation resistance at 20°:	>5000 Mohm/Km
Working temperature:	-30° ~ +70°



Specifications	
Inner conductor size:	2 x 0.14 mm ² [26 AWG]
Strands x conductor:	18 x 0.10 Flexible Bare Copper (BC) twisted to pairs
Insulation:	Dual color Polyolefin - Ø 1.00 mm
Shielding:	Served aluminium/polyester shield + 7 x 0.18 mm tinned copper drain wire - 100% coverage
Outer jacket:	PVC Super Flex
Overall diameter:	4.00 mm
Weight:	14 Kg (31.11 lbs) per 1000 m (3280 ft)
Mechanical / Electric Characteristics	
Conductor resistance at 20°:	<134 Ohm/Km
Conductor/conductor capacitance:	66Pf/m
Insulation resistance at 20°:	>10000 Mohm/Km
Working temperature:	-30° ~ +70°

CM/840

CM/870

CM/822

2-Pair Flat Multicore Cable

Reel length (meters): **100**

Colours: Black (BK)

CM/805

2-Pair Flat Multicore Cable

Reel length (meters): **100**

Colours: Black (BK)

AES/EBU - DMX - AMX DIGITAL CONNECTION CABLES MADE IN ITALY

CM/818

AES/EBU Digital Connection Cable

Reel length (meters): **100**

Colours: Black **(BK)**



Specifications

Inner conductor size:	2 x 0.18 mm ²
Insulation:	Polyolefin - Ø 1.36 mm
Shielding:	Served shielding + 0.18 mm drain wire
Outer jacket:	PVC Flex Polyvinyl Chloride
Overall diameter:	5.00 mm
Weight:	33 Kg (73.33 lbs) per 1000 m (3280 ft)

Mechanical / Electric Characteristics

Impedance:	110 Ohm
Capacitance:	46Pf/m
Conductor/shielding resistance:	23 Ohm/Km
Conductor/conductor resistance:	110 Ohm/Km
Insulation resistance at 20°:	>105 Mohm/Km
Working temperature:	-20° ~ +70°

CM/825

DMX Digital Connection Cable

Reel length (meters): **100**

Colours: Black **(BK)**



Specifications

Inner conductor size:	2 x 0.25 mm ² (Ø 1.80 mm)
Strands x conductor:	14 x 0.15 Stranded Bare Copper (BC)
Insulation:	Dual colour PE (Polyethylene)
Core arrangement:	Twisted to pairs with PVC filling
Shielding:	Tinned copper braid shielding, 0.10 mm, 90% coverage + Alu/PET foil
Outer jacket:	Flex PVC
Overall diameter:	5.40 mm
Weight:	51.5 Kg (114.44 lbs) per 1000 m (3280 ft)

Mechanical / Electric Characteristics

Impedance:	120 Ohm
Conductor resistance at 20°C (Ohm/Km):	According to standard IEC 228/HD 383 S2 (CEI 20-29)
Resistance to flame propagation:	According to the standard IEC 332-1 (CEI 20-35)
Voltage Rating (V):	300/300
Voltage Test (V):	2.000
Working temperature:	+60°C

CM/826

AMX 120 Ohm Digital Connection Cable (combines DMX and Power signals)

Reel length (meters): **100**

Colours: Black **(BK)**



Specifications

Inner conductor size:	2 x 0.34 mm ² 2 DMX + 2 x 2.00 mm ² 2 POWER
Insulation:	DMX: Dual colour XLPE Polythene Ø 1.20 mm - POWER: Dual colour PVC Ø 2.80 mm
Shielding:	Drain wire + served alufoil shield (100% coverage) + cotton
Outer jacket:	PVC Polyvinyl Chloride
Overall diameter:	7.50 mm
Weight:	80 Kg (177.78 lbs) per 1000 m (3280 ft)

Mechanical / Electric Characteristics

Impedance:	120 Ohm
Conductor resistance at 20°:	DMX: >60 Ohm/Km - POWER: >40 Ohm/Km
Conductor/shielding capacitance:	104Pf/m
Conductor/conductor capacitance:	66Pf/m
Insulation resistance at 20°:	DMX: <100000 Mohm/Km - POWER: <6 Mohm/Km
Inductance:	>0.50 mH/Km
Working temperature:	-25° ~ +70°

Bulk Cables

AES/EBU - DMX - AMX DIGITAL CONNECTION CABLES MADE IN ITALY



CM/828

Multicore DMX 120 Ohm Super Flex Digital Cable
4-Pair cable delivers up to 2048 DMX channels

Reel length (meters): **100**
Colours: Black **(BK)**

Specifications	
Inner conductor size:	2 x 0.22 mm ² Bare Copper Twisted to 4 pairs
Insulation:	Dual colour Polythene Ø 1.20 mm
Single-pair jacket:	PVC Flex - Ø 3.40 mm
Shielding:	Braided tinned copper shield (90%) + drain wire + alufoil shield (100%)
Outer jacket:	PVC Super Flex
Overall diameter:	11.20 mm
Weight per 1000 m (3280 ft):	138 Kg (306.67 lb)
Mechanical / Electric Characteristics	
Impedance:	120 Ohm
Conductor resistance at 20°:	<87 Ohm/Km
Inductance:	<0.37 MH/Km
Conductor/conductor capacitance:	37Pf/m
Insulation resistance at 20°:	>10000 Mohm/Km
Test voltage:	1000 V DC
Working temperature:	-25° ~ +70°

ETHERNET DIGITAL CONNECTION CABLES MADE IN ITALY



ETH/1007

Ethernet CAT6 Digital Connection Shielded Cable

Reel length (meters): **100**
Colours: Black **(BK)**

Specifications	
Inner conductor size:	7 x 0.20 (4 x 2 x 0.22mm ²) Bare Copper
Insulation:	Multiple color LPE Polythene - Ø 1.00 mm
Shielding:	Aluminium foil, served tinned copper braid with drain wire
Inner jacket:	MYLAR overlapping foil
Outer jacket:	PVC Super Flex
Overall diameter:	7.20 mm
Weight:	47 Kg (104.44 lbs) per 1000 m (3280 ft)
Mechanical / Electric Characteristics	
Conductor resistance at 20°:	<100 Ohm/Km
Conductor/conductor capacitance:	62 Pf/m
Insulation resistance at 20°:	>7000 Mohm/Km
Working temperature:	-20° ~ +70°

ETH/1004

Ethernet CAT5e Digital Connection Shielded Cable with double jacket for mobile installations

Reel length (meters): **100**
Colours: Black **(BK)**



Specifications	
Inner conductor size:	7 x 0.20 mm (4 x 2 x 0.22 mm ²) Bare Copper
Insulation:	Multiple color Polyolephine - Ø 0.95 mm
Shielding:	Aluminium foil, tinned copper braid with drain wire
Inner jacket:	MYLAR overlapping foil
Outer jacket:	PVC Super Flex - Ø 6.00 mm
Weight:	55 Kg (122.22 lbs) per 1000 m (3280 ft)
Mechanical / Electric Characteristics	
Conductor resistance at 20°:	<134 Ohm/Km
Conductor/shielding capacitance:	194Pf/m
Conductor/conductor capacitance:	123Pf/m
Insulation resistance at 20°:	>10000 Mohm/Km
Working temperature:	-20° ~ +60°

VIDEO CONNECTION CABLES MADE IN ITALY

CM/858

Video Connection Coaxial Cable

Reel length (meters): **100**

Colours: Black (BK)



Specifications

Inner conductor size:	19 x 0.18 mm ² Tinned Copper
Insulation:	Polyethylene - Ø 2.90 mm
Shielding:	Braided tinned copper shield [16 x 7 x 0.12]
Outer jacket:	PVC Super Flex [0.76 mm thickness]
Overall diameter:	5.00 mm
Weight:	40 Kg (88.88 lbs) per 1000 m (3280 ft)

Mechanical / Electric Characteristics

Impedance:	50 Ohm
Capacitance:	97Pf/m
Shielding resistance:	<14 Ohm/Km
Conductor resistance:	<38 Ohm/Km
Insulation resistance:	>10000 Mohm/Km
Electric tension:	1900 kV
Speed of propagation:	66%
Working temperature:	-30° ~ +80°

CM/861

Video Connection Cable - 3 Coaxial Conductors

Reel length (meters): **100**

Colours: Black (BK)



Specifications

Inner conductor size:	7 x 0.12 mm ²
Insulation:	Polyethylene foam - Ø 1.60 mm
Coaxial RGB insulation:	PVC - Ø 2.60 mm (red, green, blue)
Outer jacket:	PVC
Overall diameter:	8.10 mm
Weight:	69 Kg (153.33 lbs) per 1000 m (3280 ft)

Mechanical / Electric Characteristics

Impedance:	75 Ohm
Capacitance:	55Pf/m
Conductor resistance at 20°:	62 Ohm/Km
Insulation resistance:	>10000 Mohm/Km
Speed of propagation:	80%
Working temperature:	-30° ~ +70°

CM/869

Video Connection Cable - 5 Coaxial Conductors

Reel length (meters): **100**

Colours: Black (BK)



Specifications

Inner conductor size:	7 x 0.12 mm ²
Insulation:	Polyethylene foam - Ø 1.60 mm
Coaxial RGB insulation:	PVC - Ø 2.60 mm (red, green, blue)
Outer jacket:	PVC
Overall diameter:	9.50 mm
Weight:	98 Kg (217.77 lbs) per 1000 m (3280 ft)

Mechanical / Electric Characteristics

Impedance:	75 Ohm
Capacitance:	55Pf/m
Conductor resistance at 20°:	62 Ohm/Km
Insulation resistance:	>10000 Mohm/Km
Inductance:	0.60 MH/Km
Speed of propagation:	80%
Working temperature:	-30° ~ +70°

Bulk Cables

MAINS/AUDIO CABLES



CA/836 CA/896

	CA/836	CA/896
	Mains/Audio Cable	Mains/Audio Cable
Reel length (meters):	100	100
Colours:	Black (BK)	Black (BK)
Audio Cable Specifications		
Inner conductor size:	2 x 0.25 mm ²	
Conductor colours:	White - Red (Twisted)	
Insulation:	Polyethylene - Ø 1.20 mm	
Shielding:	Tinned copper (90%) + drain wire + alufoil (100%)	Tinned copper (90%) + drain wire + alufoil (100%)
Outer jacket:	Black PVC Super Flex - Ø 4.00 mm	
Audio Cable Mechanical / Electric Characteristics		
Impedance:	90 Ohm	
Conductor resistance at 20°:	<77 Ohm/Km	
Inductance:	0.60 MH/Km	
Capacitance:	57Pf/m	
Insulation resistance:	>10000 Mohm/Km	
Mains Cable Specifications		
Inner conductor size:	3 x 1.5 mm ²	3 x 2.5 mm ²
Conductor colours:	Blue - Brown - Green (Twisted)	
Insulation:	PVC - Ø 2.50 mm	PVC - Ø 2.90 mm
Outer jacket:	PVC Super Flex	
Mains Cable Mechanical / Electric Characteristics		
Conductor resistance at 20°:	<14 Ohm/Km	<10 Ohm/Km
Insulation resistance:	>13 Mohm/Km	>12 Mohm/Km
Overall jacket (1 Mains + 1 Audio Cables)		
	PVC Super Flex - Ø 10.00 mm	PVC Super Flex - Ø 10.50 mm
Weight per 1000 m (3280 ft): (1 Mains + 1 Audio Cables)		
	132 Kg (293.33 lbs)	166 Kg (368.8 lbs)

SUPERFLEX SERIES MAINS CABLES MADE IN ITALY

CSF/3015 CSF/3025
CSF/5006 CSF/5016



	CSF/3015	CSF/3025	CSF/5006	CSF/5016
	Mains Cable	Mains Cable	Mains Cable	Mains Cable
Specifications				
Inner conductor size:	3 x 1.5 mm ²	3 x 2.5 mm ²	5 x 6 mm ²	5 x 16 mm ²
Strands x conductor:	29 x 0.25	48 x 0.25	112 x 0.25	306 x 0.25
Conductor material:	Tinned Copper			
Conductor diameter:	3 mm +/- 0.1%	3.45 mm +/- 0.1%	4.9 mm +/- 0.1%	7.7 mm +/- 0.1%
Insulation thickness:	0.7 mm	0.75 mm	0.8 mm	1.2 mm
Outer jacket thickness:	PVC 1 mm	PVC 1 mm	PVC 1.5 mm	PVC 2.5 mm
Overall diameter:	8.4 mm +/- 0.2%	10 mm +/- 0.2%	16.2 mm +/- 0.2%	26 mm +/- 0.2%
Weight per 1000 m (3280 ft):	118 Kg [262.22 lbs]	175 Kg [388.89 lbs]	545 Kg [1211 lbs]	1396 Kg [3102 lbs]
Colours:	Black (BK)			
Mechanical / Electric Characteristics				
Working temperature:	-30° ~ +90°			
Flexibility at low temperatures:	High Flexibility / -30° Cold Flex			
Resistance at 20°:	In compliance with IEC 228/HD 383 S2 (CEI 20-29) Norms			
Flame resistance:	In compliance with IEC 332/-1 (CEI 20-35) Norms			
Non-flame propagating:	In compliance with CEI 20-22/II (IEC 332/-3/A/B/C) and CEI 20-37 Norms			



Bulk Cables

SUPERFLEX SERIES MAINS CABLES



CSF/1015 CSF/1215 CSF/1915
CSF/1025 CSF/1225

	CSF/1015	CSF/1215	CSF/1915	CSF/1025	CSF/1225
	Mains Cable	Mains Cable	Mains Cable	Mains Cable	Mains Cable
Specifications					
Inner conductor size:	10 x 1.5 mm ²	12 x 1.5 mm ²	19 x 1.5 mm ²	10 x 2.5 mm ²	12 x 2.5 mm ²
Strands x conductor:	29 x 0.25	29 x 0.25	29 x 0.25	48 x 0.25	48 x 0.25
Conductor material:	Tinned Copper				
Conductor diameter:	3.0 mm +/- 0.1%	3.0 mm +/- 0.1%	2.85 mm +/- 0.1%	3.45 mm +/- 0.1%	3.45 mm +/- 0.1%
Insulation thickness:	0.7 mm	0.7 mm	0.7 mm	0.75 mm	0.75 mm
Outer jacket thickness:	PVC 1.5 mm	PVC 1.5 mm	PVC 1.6 mm	PVC 1.8 mm	PVC 1.8 mm
Overall diameter:	15 mm +/- 0.2%	15.5 mm +/- 0.2%	17.5 mm +/- 0.2%	17.5 mm +/- 0.2%	18.0 mm +/- 0.2%
Weight per 1000 m (3280 ft):	375 Kg (833.3 lb)	410 Kg (911.1 lb)	590 Kg (1311.1 lb)	546 Kg (1213.3 lb)	597 Kg (1326.6 lb)
Colours:	Black [BK]				
Mechanical / Electric Characteristics					
Working voltage:	300 / 500 V				
Working temperature:	-30° ~ +90°				
Flexibility at low temperatures:	High Flexibility / -30° Cold Flex				
Resistance at 20°:	In compliance with IEC 228/HD 363 S2 (CEI 20-29) Norms				
Flame resistance:	In compliance with IEC 332/-1 (CEI 20-35) Norms				
Non-flame propagating:	In compliance with CEI 20-22/II (IEC 332/-3/A/B/C) and CEI 20-37 Norms				

“2000-SERIES” CONNECTING CABLES FOR NON POWERED SPEAKERS



CA/215 CA/225 CA/24
CA/26 CA/425 CA/44

	CA/215	CA/225	CA/24	CA/26	CA/425	CA/44
	Speaker Cable	Speaker Cable	Speaker Cable	Speaker Cable	Speaker Cable	Speaker Cable
Specifications						
Inner conductor size:	2 x 1.5 mm ²	2 x 2.5 mm ²	2 x 4.0 mm ²	2 x 6.0 mm ²	4 x 2.5 mm ²	4 x 4.0 mm ²
Inner conductor:	Bare Copper - Class 5 according to standard IEC 228/HD 383 S2 (CEI 20-29)					
Strands x conductor:	28 x 0.245	48 x 0.245	80 x 0.245	81 x 0.30	48 x 0.245	53 x 0.30
Conductor diameter:	2.7 mm	3.2 mm	4.0 mm	4.9 mm	3.45 mm	4.3 mm
Insulation:	FLEX PVC - T12 quality according to standard HD 21 (CEI 20-11)					
Outer jacket:	FLEX PVC - TM2 quality according to standard HD 21 (CEI 20-11)					
Overall diameter:	7.0 mm	8.4 mm	10.8 mm	12.2 mm	11.0 mm	13.3 mm
Weight per 1000 m (3280 ft):	79 Kg (175.5 lbs)	118 Kg (262.2 lbs)	205 Kg (455.5 lbs)	258 Kg (573.3 lbs)	200 Kg (444.4 lbs)	370 Kg (822.2 lbs)
Reel length (meters):	100					
Colours:	Black [BK]					
Mechanical / Electric Characteristics						
Working voltage:	300 / 500 V					
Working temperature:	60°					
Electrical resistance at 20°C [Ohm/Km]:	According to standard IEC 228/HD 383 S2 (CEI 20-29)					
Resistance to flame propagation:	According to the standard IEC 332-1 (CEI 20-35)					

“800-SERIES” CONNECTING CABLES FOR NON POWERED SPEAKERS

MADE IN ITALY

CA/810 **CA/820**
CA/822 **CA/830** **CA/840**



	CA/810	CA/820	CA/822	CA/830	CA/840
	Speaker Cable	Speaker Cable	Speaker Cable	Speaker Cable	Speaker Cable
Specifications					
Inner conductor size:	2 x 1.0 mm ²	2 x 1.5 mm ²	2 x 2.0 mm ²	2 x 2.5 mm ²	2 x 4.0 mm ²
Strands x conductor:	32 x 0.193	49 x 0.193	67 x 0.193	84 x 0.193	80 x 0.25
Conductor diameter:	2.50 mm +/- 0.1%	2.85 mm +/- 0.1%	3.20 mm +/- 0.1%	3.45 mm +/- 0.1%	4.00 mm +/- 0.1%
Insulation thickness:	0.6 mm	0.7 mm	0.7 mm	0.7 mm	0.7 mm
Outer jacket thickness:	PVC 0.8 mm	PVC 0.85 mm	PVC 0.8 mm	PVC 0.9 mm	PVC 0.8 mm
Overall diameter:	6.7 mm +/- 0.2%	7.4 mm +/- 0.2%	7.9 mm +/- 0.2%	9.0 mm +/- 0.2%	11.0 mm +/- 0.2%
Unit ultimate strength:	1.45 Kg/mm ²				
Tensile strength:	220%				
Weight per 1000 m (3280 ft):	68 Kg (151.1 lbs)	86 Kg (191.1 lbs)	98 Kg (217.8 lbs)	132 Kg (293.3 lbs)	171 Kg (380 lbs)
Reel length (meters):	100				
Colours:	Black (BK)				
Mechanical / Electric Characteristics					
Working voltage:	300 / 500 V				
Working temperature:	60°				
Electrical resistance:	18.0 Ohm/Km	12.0 Ohm/Km	7.94 Ohm/Km	7.4 Ohm/Km	5.0 Ohm/Km
Reference regulation:	Complying with CEI 20-20 Norms				
Self-extinguishing rate:	Positive (in compliance with CEI norms)				

CA/807 **CA/806**



	CA/807	CA/806
	Speaker Cable	Speaker Cable
Specifications		
Inner conductor size:	4 x 4.0 mm ²	6 x 2.5 mm ²
Strands x conductor:	53 x 0.30	49 x 0.24
Conductor diameter:	4.20 mm +/- 0.1%	3.45 mm +/- 0.1%
Insulation thickness:	0.8 mm	0.7 mm
Outer jacket thickness:	PVC 1.4 mm	PVC 1.1 mm
Overall diameter:	13.2 mm +/- 0.2%	13.0 mm +/- 0.2%
Unit ultimate strength:	1.45 Kg/mm ²	
Tensile strength:	220%	
Weight per 1000 m (3280 ft):	305 Kg (677.8 lbs)	309 Kg (686.6 lbs)
Reel length (meters):	100	
Colours:	Black (BK)	
Mechanical / Electric Characteristics		
Working voltage:	300 / 500 V	
Working temperature:	60°	
Electrical resistance:	4.5 Ohm/Km	7.4 Ohm/Km
Reference regulation:	Complying with CEI 20-20 Norms	
Self-extinguishing rate:	Positive (in compliance with CEI norms)	

Bulk Cables

CONNECTING CABLES FOR NON POWERED SPEAKERS MADE IN ITALY

D/82 "NPI" NON-FLAME-PROPAGATING CABLE FOR NON POWERED SPEAKERS SUITABLE FOR BOTH MOBILE AND PERMANENT INSTALLATIONS



D/82

NPI Non-Flame-Propagating Speaker Cable

Specifications	
Inner conductor size:	2 x 1.5 mm ²
Strands x conductor:	29 x 0.245
Conductor diameter:	2.85 mm +/- 0.1%
Insulation thickness:	0.7 mm
Outer jacket thickness:	NPI 0.85 mm
Overall diameter:	7.4 mm +/- 0.2%
Unit ultimate strength:	1.45 Kg/mm ²
Tensile strength:	220%
Weight per 1000 m (3280 ft):	86 Kg [191.1 lbs]
Reel length (meters):	100
Colours:	Black (BK)

Mechanical / Electric Characteristics	
Working voltage:	300 / 500 V
Working temperature:	60°
Electrical resistance:	12.0 Ohm/Km
Reference regulation:	Complying with CEI 20-20 Norms
Self-extinguishing rate:	Positive (in compliance with CEI norms)

D/96 FIRE-RESISTANT CABLE FOR NON POWERED SPEAKERS, FEATURING FLAME-RETARDANT (FROR) SHIELDING - BEST SOLUTION FOR PERMANENT INSTALLATIONS



D/96 RE

Flame-Retardant Speaker Cable

Specifications	
Inner conductor size:	2 x 2.5 mm ²
Strands x conductor:	Bare copper (IEC 60228 Class 5)
Insulation:	PVC - Ø 2.90 mm (Blue/Red)
Core arrangement:	Twisted to pairs in concentric layers with cotton filling
Insulation thickness:	0.39 mm
Shielding:	Braided tinned copper shield
Outer jacket thickness:	Flame-Retardant PVC
Overall diameter:	8.10 mm
Weight per 1000 m (3280 ft):	122 Kg [271 lbs]
Reel length (meters):	100
Colours:	Red (RE)

Mechanical / Electric Characteristics	
Conductor resistance at 20°:	< 8.7 Ohm/Km
Insulation resistance at 20°:	> 30 Mohm/Km
Conductor/shielding capacitance:	145Pf/m
Conductor/conductor capacitance:	85Pf/m
Electric tension:	3 kV
Working temperature:	-20° ~ +80°



- index -

INDEX

MODEL	SECTION / PAGE	MODEL	SECTION / PAGE	MODEL	SECTION / PAGE
[A]					
A/107	03-19, 04-7	BOX/644-30K	16-48	CM/184PN	16-34
A/114	03-18	BOX/646-20K	16-48	CM/186PN	16-34
A/156	03-16	BOX/647-30K	16-48	CM/188	16-26
A/188	03-18	BS/300	05-2	CM/189	16-26
A/25	03-18	BS/310	09-6	CM/204	16-24
A/300	03-2	BS/313	05-4, 09-2	CM/205	16-24
A/302	03-4	BS/317	09-2	CM/206	16-24
A/302PACK-1	03-7	BS/402	05-2	CM/207	16-24
A/302PACK-2	03-6	BS/536	05-3	CM/208	16-24
A/304	03-5	BS/542	05-3	CM/580	17-5
A/305	03-4	BS/545	05-3	CM/675	17-5
A/306	03-5	BS/619	01-22, 05-4, 09-6	CM/780	17-6
A/340	03-2	BS/620	09-3	CM/805	17-8
A/341	03-3	BS/625	09-4	CM/818	17-9
A/344	03-2	BW/768	14-2	CM/825	17-9
A/346	03-3	BX/14	02-5	CM/826	17-9
A/386	03-6	BX/6	02-9	CM/828	17-10
A/399	03-6	BX/718	02-6	CM/840	17-8
A/492	03-8	BX/8	02-4	CM/858	17-11
A/494	03-9	BX/9	02-4	CM/861	17-11
A/495	03-7	BZ/7	02-8	CM/869	17-11
A/496	03-9			CM/870	17-8
A/50	03-14	[C]			
A/512	03-10	CA/215	17-14	CM/900	17-6
A/514	03-11	CA/225	17-14	CM/995	17-5
A/516	03-11	CA/24	17-14	CMF/832	17-7
A/85	03-15	CA/26	17-14	CMF/834	17-7
A/987	03-13	CA/425	17-14	CMF/838	17-7
A/988	03-12	CA/44	17-14	CMF/842	17-7
A/989	03-13	CA/806	17-15	CMF/846	17-7
AAR	16-45	CA/807	17-15	CMF/854	17-7
AD/100PN	16-34	CA/810	17-15	CMF/862	17-7
AD/87PN	16-34	CA/820	17-15	CMF/865	17-7
		CA/822	17-15	CMF/866	17-7
		CA/830	17-15	CS/535	17-3
		CA/836	17-12	CS/732	17-3
		CA/840	17-15	CSF/1015	17-14
		CA/896	17-12	CSF/1025	17-14
		C-AES/EBU	16-46	CSF/1215	17-14
		CB/6-2	05-11	CSF/1225	17-14
		CM/175AM	16-32	CSF/1915	17-14
		CM/175K	16-12	CSF/3015	17-13
		CM/175PN	16-34	CSF/3025	17-13
		CM/180	16-26	CSF/5006	17-13
		CM/181	16-26	CSF/5016	17-13
		CM/182	16-26	[D]	
		CM/183F	16-27	D/82	17-16
		CM/183M	16-27	D/96 RE	17-16

MODEL	SECTION / PAGE
DB/3V	02-10
DB/5V	02-10
DB/9V	02-10
DB/S	02-10
DJ/233	08-5
DMX/1400	16-46
DMX/1401	16-46
DMX/1404	16-46
DSP/390	05-17, 08-11
DSP/590	08-11
DX/749	02-7

[E]

ETH/1004	17-10
ETH/1007	17-10
ETH/5	16-47
ETH/6	16-47
ETH5/61.5	16-47
ETH6/61.5	16-47

[F]

FAP/01	03-20
FAP/05	03-20
FPC/Q	16-41
FPC/QUIKBOARD	16-21
FPC/QUIKBOARD JAR PACK	16-21
FPC/UNI	16-42
FPC/V-C2	16-39
FS/01	06-8

[G]

GI/8	06-7
GS/350	06-14
GS/402	06-16, 13-7
GS/403	06-16, 13-7
GS/405	13-12
GS/410	06-17, 13-8
GS/413	06-17, 13-8
GS/430	06-12
GS/434	06-8
GS/435	06-8
GS/436	06-6
GS/437	06-6
GS/438	06-6
GS/450	06-13
GS/454	06-16, 13-7

MODEL	SECTION / PAGE
GS/454L	06-16, 13-7
GS/460	06-15
GS/460EXT	06-15
GS/471	06-13
GS/508	06-2
GS/528	06-3
GS/538	06-3
GS/701	06-17, 13-9
GS/701L	06-17, 13-9
GS/701XL	06-17, 13-9

[I]

IPS/12	03-17, 08-10
IPS/13	01-25, 01-35
IPS/16	08-9, 12-6

[J]

JUST 2JR	16-17
JUST 2RCA2J	16-19
JUST 4RCA	16-19
JUST FJM	16-18
JUST FJS	16-18
JUST J352J	16-20
JUST J352RCA	16-20
JUST J35J35	16-20
JUST J35J35F	16-20
JUST J35JS	16-20
JUST JJ	16-17
JUST JJ SL	16-17
JUST JM35JM	16-19
JUST JR	16-17
JUST JR SL	16-17
JUST JS	16-17
JUST JS2JM	16-19
JUST JS2RCA	16-19
JUST KEY	16-19
JUST MF	16-18
JUST MF SL	16-18
JUST MJM	16-18
JUST MJS	16-18

[L]

LPH/001	08-8, 11-3
LPH/004	08-7
LPH/005	08-6
LPH/T	08-9, 12-6

MODEL	SECTION / PAGE
LPH/X	01-24, 01-34

[M]

M/2	01-7
M/61	01-6
M/91	01-7
MCR/611K	16-12
MCR/612K	16-12
MCR/613K	16-12
MCR/614K	16-12
MCR/615K	16-12
MCR/616K	16-13
MCR/617K	16-13
MP/840	03-20
MP/850	03-20
MP/890	03-20
MP/891	03-20
MP/892	03-20
MP/900	03-20
MPB/412	16-30
MPB/418	16-30
MPB/419	16-30
MS/19LED	04-7
MS/22LED	04-6
MS/303	03-18, 04-8
MS/307	04-6
MS/320	04-2
MS/326	03-19, 04-8
MS/327	01-25, 01-28, 01-38, 03-19, 04-8
MS/329	03-19, 04-8
MS/330	04-4
MS/330 W/BAG	04-4
MS/331	04-4
MS/331 W/BAG	04-4
MS/332	04-2
MS/334	04-5
MS/335	04-5
MS/766	04-3
MST/767	04-3
MX/775	16-2
MX/777	16-2
MX/779	16-2

[P]

PB/010 BK	02-2
PB/100 BK L	02-3
PB/100 BK S	02-3

INDEX

MODEL	SECTION / PAGE
PB/100 WH S	02-3
PB/100 WN S	02-3
PB/50 BK S	02-2
PB/50 WH S	02-2
PL/010LED	04-7
PS/20	15-2
PS/25	15-2
PSP/125	15-3

[Q]

QCC/1	05-23
QF/410	13-11
QF/413	13-11
QF/51	13-11
QF/548	13-10
QF/597	01-39, 13-10
QL/322	01-18, 05-4
QL/400	11-6
QL/623	01-12
QL/631	06-4
QL/632	06-5
QL/633	06-5
QL/636	01-39, 13-10
QL/640	09-3
QL/642	01-13
QL/646	01-13
QL/648	01-39
QL/662	01-24
QL/691	06-10
QL/692	06-11
QL/694	06-11
QL/723	01-10
QL/742	01-11
QL/746	01-11
QL/791	06-9
QL/95	05-8
QL/950	05-8
QL/953	05-6
QL/956	05-7
QL/958	05-9
QLC/1U	05-23
QLX/3	01-23
QLX/4	01-23, 01-35
QLX/5	01-24, 01-35
QLY/40	01-9
QLY/42	01-9
QUIKSILVER	16-41
QUIKSILVER A5	16-41

MODEL	SECTION / PAGE
QUIKSILVER AS5	16-41
QUIKSILVER S5	16-41

[R]

RKSA/100	16-6
RKSA/110	16-7
RKSA/120	16-7
RKSA/128	16-7
RKSA/130	16-7
RKSA/132	16-8
RKSA/133	16-8
RKSA/138	16-8
RKSA/139	16-8
RKSA/140	16-8
RKSA/150	16-8
RKSA/160	16-7
RKSA/180	16-7
RKSA/192	16-9
RKSA/194	16-9
RKSI/200	16-5
RKSI/202	16-5
RKSI/205	16-5
RKSI/207	16-5
RKSM/300	16-6
RKSM/310	16-6
RKSM/340	16-6
RKSM/342	16-6
RKSM/344	16-6
RS/10	10-3
RS/241	10-10
RS/242	10-9
RS/243	10-11
RS/245	10-9
RS/246	10-10
RS/247	10-9
RS/248	10-9
RS/249	10-9
RS/276	10-10
RS/277	10-10
RS/278	10-10
RS/281	10-11
RS/289	10-11
RS/290	10-11
RS/292	10-11
RS/293	10-12
RS/294	10-12
RS/295	10-12
RS/296	10-12

MODEL	SECTION / PAGE
RS/297	10-12
RS/299	10-9
RS/507	10-6
RS/510	10-5
RS/512	10-5
RS/513	10-6
RS/514	10-5
RS/516	10-6
RS/655	10-3
RS/656	10-3
RS/660	10-7
RS/668	10-7
RS/669	10-8
RS/670	10-8
RS/671	10-8
RS/673	10-7

[S]

S/1200 EU STND	16-45
S/160AM	16-32
S/160PN	16-33
S/165	16-46
S/167PN	16-33
S/171	05-10
S/171PAK	05-10
S/173	05-11
S/176	05-11
S/191-1.5	05-22
S/195	05-22
S/198AM	16-32
S/198PN	16-33
S/200K	16-11
S/203	05-20
S/204	16-23
S/205	16-23
S/206	16-23
S/210	16-25
S/211	16-25
S/213	05-20
S/213	16-25
S/214	16-26
S/215	16-27
S/216	16-27
S/217	16-27
S/218	16-27
S/220	16-28
S/221	16-28
S/223	16-28

INDEX

MODEL	SECTION / PAGE
WS/650	01-33, 05-5, 08-3, 11-4
WS/651	01-34, 11-5

[Z]

Z/2ALU	01-31
Z/460 BK	12-4
Z/612 BK	12-5
Z/612 CY	12-5
Z/630 BK	12-3
Z/630 CY	12-2
Z/716	01-26
Z/716L	01-26
Z/71ALU	01-31
Z/720	01-29
Z/720L	01-29
Z/726	01-27
Z/726L	01-27
Z/727	01-29, 01-37
Z/728	01-28
Z/729	01-30, 01-37
Z/731	01-28
Z/733	01-30, 01-37
Z/735	01-3, 01-28
ZM/99	01-30





Technical data and appearance of products are subject to change without prior notice.
This catalogue issue supersedes any previous one.

*Printed by: Tecnostampa - Pigni Group Printing Division
Loreto, Trevi - 2018*

QUIK LOK[®]
STANDS APART FROM THE REST

QUIK LOK is a division of di Eko Music Group

QUIKLOK.IT

EKO MUSIC
GROUP

DAL 1959 LA STESSA PASSIONE

EKO MUSIC GROUP SpA

Offices and Warehouse: Via Oliviero Pigni, 8 (Zona Ind.le Aneto) - 62010 Montelupone (Mc) - Italy
Tel. +39 0733 227 1 Fax +39 0733 227 250 info@quiklok.it

EKOMUSICGROUP.COM

©2020 Quik Lok, a division of Eko Music Group S.p.A. Data, text and pictorial material may not be reproduced in any manner without prior written permission of Quik Lok, a division of Eko Music Group S.p.A. © All rights reserved. This catalogue issue supersedes any previous one. The information contained in this catalogue has been carefully drawn up and checked, however no responsibilities will be assumed for any inexactitude. Technical data and appearance of products are subject to change without prior notice. Images are for demonstration purposes only. Products may change due to technological developments and compliance to regulations.

speakON® is a registered trademark under the property Neutrik® AG.
iPad® is a trademark registered by Apple® Inc.

Printed in Italy - January 2020

EKO MUSIC GROUP
SINCE 1959 THE SAME PASSION

EKO Music Group SpA

Via Falleroni, 92 - P.O. Box 58
62019 Recanati (MC) - Italy

Offices and Warehouse:
Via Oliviero Pignini, 8 - Zona Ind.le Aneto
62010 Montelupone (MC) - Italy

T +39 0733 227 1
F +39 0733 227 250

info@ekomusicgroup.com

www.ekomusicgroup.com
www.quiklok.it

QUIK LOK is exclusively distributed by:

